

AirTAC

PRODUCTS CATALOG-2025

Linear Guide(Europe)

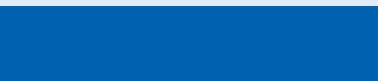

AirTAC ● Linear Guide

Products Catalog-2025

- LSH Series Standard Linear Guide
- LSD Series Low Profile Type Linear Guide
- LSQH Series Caged Ball Type Linear Guide
- LRW Series Miniature Linear Guide (Widened)
 - LRM Series Miniature Linear Guide
 - LGC Series Crossed Roller Way

Corporate Profile

Annual revenue over the years

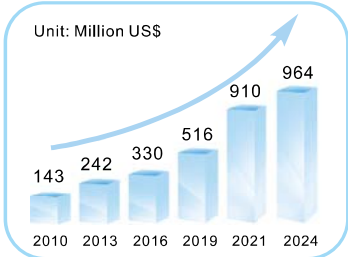

2019:
AirTAC Ningbo the second
Production base established



2018:
AirTAC USA established



2016-2018:
AirTAC(Guangdong/Tianjin
/Fujian) Intelligent Company
established



2012-2015:
AirTAC Singapore, AirTAC
Japan, AirTAC Malaysia,
AirTAC Thailand established



2015:
AirTAC (Jiangsu)
established

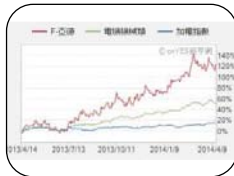

2010:
AirTAC IPO In Taiwan
(Stock code: 1590.TW)



2016:
New production
base of AirTAC
Tainan established

2011:
Expanded China Sales
and R&D center



2008:
AirTAC Italy
established



2002:
AirTAC Ningbo
established

1988:
AirTAC Taiwan
established



1998:
AirTAC Guangdong
established





Corporate Profile



● **2019**
 AirTAC Ningbo the second Production base established

AirTAC Ningbo the second Production base
 Land area: 266,667m²
 Add: No.89, Nandu Rd., Fenghua District, Ningbo, Zhejiang, China

● **2016**
 New production base of AirTAC Tainan established

Taiwan Tainan Production base
 Land area: 71,333m²
 Add: No.28, Kanxi Rd., Xinshi District, Tainan, Taiwan



● **2002**
 AirTAC Ningbo established

AirTAC Ningbo the first Production base
 Land area: 240,000m²
 Add: No.88, Siming E. Rd., Fenghua District, Ningbo, Zhejiang, China



● **1998**
 AirTAC Guangdong established

AirTAC Guangdong
 Land area: 26,667m²
 Add: No.7, Kaixuan Rd., Nanhai District, Foshan, Guangdong, China





Manufacturing Equipment

Injection molding Equipment Array (Japan-made)



Cryogenic-treatment Equipment



Machining Equipment Array(Japan-made)

EFD Induction Hardening Equipment (Norway-made)



IPSEN Carburising Equipment(Germany-made)



Grinding Machine Array



Auto-assembly Line

Precision Drilling Machine(Japan-made)





Detection Equipment·R&D Experimental Equipment

Zeiss Coordinate Measuring Machine(CMM)(Germany-made)



Rail Accuracy Classification Equipment

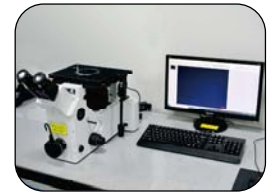
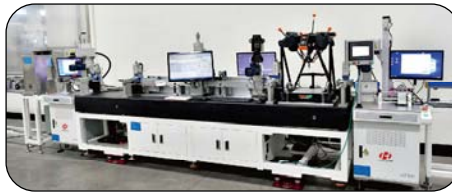

Metallographic Analysis(Japan-made)

Hardness Detection Equipment
(Netherlands-made)



Renishaw Equator

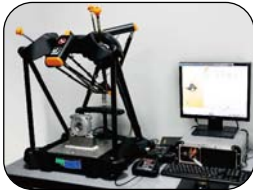

Chemical Analysis Equipment
(Germany-made)



Linear guide accuracy
Measurement Equipment



Linear guide life span Test Equipment

Linear guide complex
performance Test Equipment





Global Network of Marketing & Service

AirTAC International Group has more than 100 direct sales branches/sales sections in Chinese mainland, and thousands of distributors around the world, mainly located in Europe, the United States and Asia, etc., forming a perfect sales network and after-sales service system, which can provide customers with convenient services at any time.



Overseas Market

- USA
- Japan
- UK
- France
- Finland
- Germany
- Thailand
- Korea
- Australia
- Mexico
- Argentina
- South Africa
- Italy
- Singapore
- Malaysia
- Greece
- Sweden
- Denmark
- India
- Brazil
- Netherlands
- Sri Lanka
- Colombia
- Jordan
- VietNam
- Indonesia
- Israel
- Turkey
- Kuwait
- Austria
- Saudi Arabia
- Peru
- Canada
- Iran
- Syria
- ...





Linear Guide Selection

P3

LSH Series Standard Linear Guide

P11

LSH Series Standard Linear Guide(Including black chromium plated).....	P11
LSH-DD/ZZ Series Dustproof standard type linear guide(Including black chromium plated).....	P26
LSH-E Series Self-lubricator Standard Linear Guide(Including black chromium plated).....	P30

- Standard type(N) and Long type(L) are available,
one block and two blocks type are available
- Square type(H), Flange type top-mount(F1),
Flange type bottom-mount(F2),
Flange type top or bottom mount(F3) block are available
- LSH15、 20、 25、 30、 35、 45.
- "BB" option available for having black chromium plated on both rail&block.



LSD Series Low Profile Type Linear Guide

P35

LSD Series Low Profile Type Linear Guide(Including black chromium plated).....	P35
LSD-DD/ZZ Series Dustproof standard type linear guide(Including black chromium plated).....	P52
LSD-E Series Self-lubricator Standard Linear Guide(Including black chromium plated).....	P58

- Short type(S) and Standard type(N) are available,
one block and two blocks type are available
- Square type(H), Flange type top-mount(F1),
Flange type bottom-mount(F2),
Flange type top or bottom mount(F3) block are available
- LSD15、 20、 25、 30、 35.
- "BB" option available for having black chromium plated on both rail&block.



LSQH Series Caged Ball Type Linear Guide

New

P65

LSQH Series Caged Ball Type Linear Guide(Including black chromium plated).....	P65
LSQH-E Series Caged Ball(Self-lubricator Standard) Type Linear Guide(Including black chromium plated).....	P81

- Standard type(N) and Long type(L) are available,
one block and two blocks type are available
- Square type(H), Flange type top-mount(F1),
Flange type bottom-mount(F2),
Flange type top or bottom mount(F3) block are available
- LSQH15、 20、 25、 30、 35.
- "BB" option available for having black chromium plated on both rail&block.





LRW Series Miniature Linear Guide (Widened)(Including black chromium plated)

P86

- Standard type(N) and Long type(L) are available,
one block and two blocks type are available
- "BB" option available for having black chromium plated on both rail&block.
- LRW7、9、12、15



LRM Series Miniature Linear Guide(Including black chromium plated)

P93

- Standard type(N) and Long type(L) are available,
one block and two blocks type are available
- "BB" option available for having black chromium plated on both rail&block.
- LRM5、7、9、12、15



LGC Series Crossed Roller Way

P100

- Accuracy class: High-accuracy and precision grade are available
- Three-row type and four-row type are available
- Roller diameter: $\Phi 1.5$ 、 $\Phi 2$ 、 $\Phi 3$ 、 $\Phi 4$ 、 $\Phi 6$



Linear Guide Selection

How to select Linear Guide

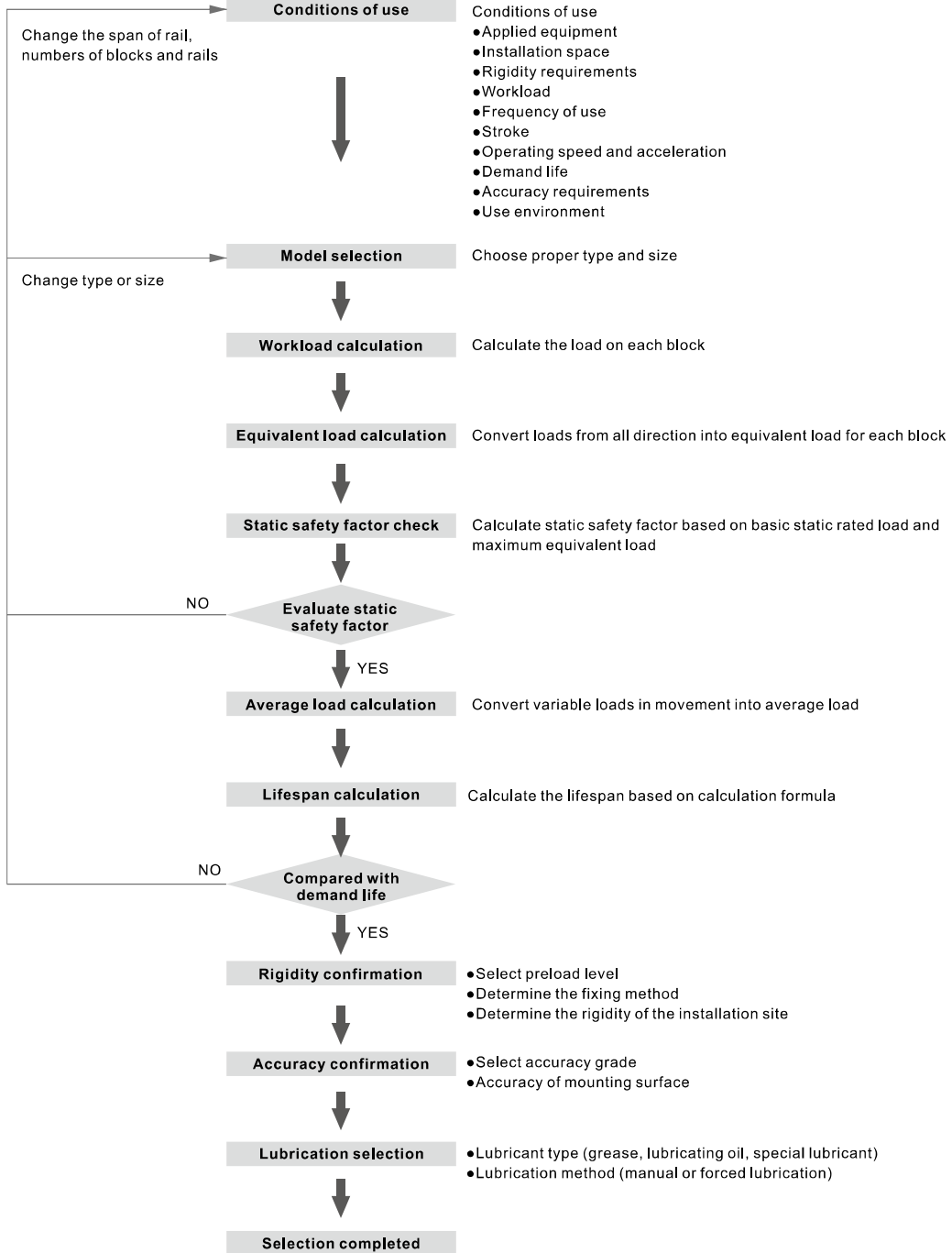

Linear Guide Selection

Load Capacity and Rating Life

1. Basic static load rating (C_0)

When a linear guide absorbs a large force or impact in a static or low-speed movement, it will cause permanent deformation either on rollers and groove. When sum of deformation on groove and rollers exceeds a certain limit, it will affect the smoothness of its linear movement.

Basic static load rating is defined as the magnitude of a given stress applied at where the stress is the biggest caused the sum of permanent deformation on groove and roller is 1/10000 of the diameter of the rollers.

2. Allowable static moment (M_0)

When torque is applied on a linear guide, rollers in the both ends of block will endure the major stress force.

Allowable static moment is defined as a given moment applied and raised stress force on linear guide which will cause sum of permanent deformation on groove and roller is 1/10000 of the diameter of the rollers.

Static moment is defined in three directions as M_P , M_V , M_R .

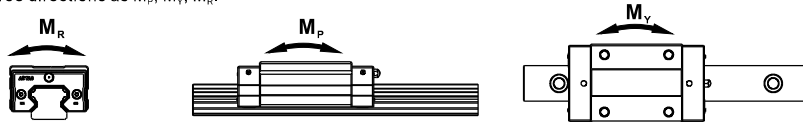

3. Static safety factor (f_s)

During vibration, impact or sudden start and stop, the inertia force or torque will raise huge loads on linear guide. For this kind of situation, it is necessary to put static safety factor into consideration. Static safety factor is a ratio of the basic static load rating to the calculated working load as shown in following formula. The reference of static safety factor for different conditions is shown in following table:

Use machinery	Load condition	f_s
General industrial machinery	General load conditions	1.0~1.3
	When there is vibration or shock	2.0~3.0
Machine tool	General load conditions	1.0~1.5
	When there is vibration or shock	2.5~7.0

$$f_s = \frac{C_0}{P} \text{ or } f_s = \frac{M_0}{M}$$

f_s : Static safety factor

C_0 : Basic static load rating (N)

M_0 : Allowable static moment (N·m)

P : Calculation load (N)

M : Calculation moment (N·m)

4. Basic dynamic load rating (C)

Basic Dynamic Load rating is defined as the maximum allowable load and can be applied on the same specification of linear guides. This will result in a nominal life of 50 KM operation for linear guide.

5. Life calculation

•Life

When a linear guide is with bearings loaded during operation, the groove and rollers will constantly endure stress force. Once reaching fatigue, the surface will peel off and damage. The life of a given linear guide is defined as the moving distance of a linear guide in which peeling occurs due to fatigue.

•Nominal life

Actual lifespan of linear guide varies enormously. The lifespan of each guide can be different even though they come from the same product batch under the same condition. Therefore, nominal life is usually chosen as bench mark to evaluate lifespan. Nominal life is defined as the moving distance for 90% of linear guides from the same production batch which can perform under the same working condition without peeling.

•Life factor

1. Hardness factor (f_H)

Surface hardness of rollers must be HRC 58~62. A softer hardness will reduce load-bearing performance and static load rating. Therefore allowable moment must be multiplied by a hardness factor as correlation shown on the right chart.

Our hardness requirement for linear guide is HRC58~62, therefore $f_H = 1.0$.

2. Temperature factor (f_T)

High temperature environment will affect lifespan of the linear guide. Therefore, static load rating and allowable moment must be multiplied by a temperature factor f_T as correlation shown on the right graph.

Certain parts of our linear guide are made of plastic and rubber, hence working in temperature higher than 100°C is not recommended.

3. Load factor (f_w)

Although loads on a given linear guide can be calculated, it will usually come with vibration or hitting in actual use. This makes actual loads higher than calculated figure. Hence, in heavy vibration or hitting condition, please divide basic dynamic load rating (C) by following empirical load factor.

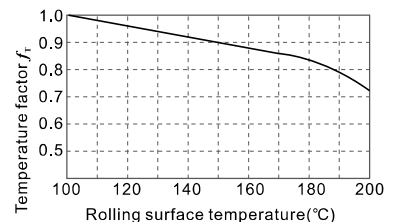
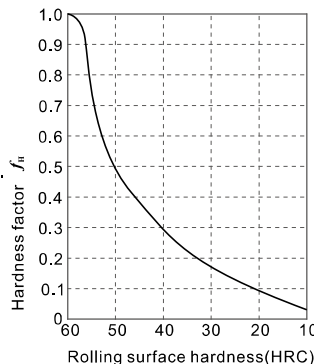

Working Conditions	Use speed	f_w
Smooth without impact	$V \leq 15\text{m/min}$	1.0~1.2
Common impact and vibration	$15\text{m/min} < V \leq 60\text{m/min}$	1.2~1.5
Moderate impact and vibration	$60\text{m/min} < V \leq 120\text{m/min}$	1.5~2.0
Strong impact and vibration	$V \geq 120\text{m/min}$	2.0~3.5

Linear Guide Selection

4. Contact factor (f_c)

When multiple blocks on the linear guide are used in close contact with each other, it is difficult to evenly distribute the load due to moment torque or the accuracy of the mounting surface. Hence, when using multiple blocks in close contact, multiply the basic load rating (C or C0) by the corresponding contact factor in the table below.

Note: Take into account the contact factor in the table below if uneven load distribution is expected in a large machine.

Number of blocks used in close contact	2	3	4	5	≥6	Normal use
Contact factor f_c	0.81	0.72	0.66	0.61	0.6	1

•Calculation of nominal life(L)

The nominal life will vary based on applied load. Hardness and working temperature will also have great effects on lifespan of a linear guide. Putting all factors into consideration, nominal life can be calculated by following formula:

$$L = \left(\frac{f_H \times f_T \times f_C}{f_W} \times \frac{C}{P} \right)^3 \times 50Km$$

- L : Nominal life (km)
- C : Basic dynamic load rating (N)
- P : Workload (N)
- f_w : Load factor
- f_H : Hardness factor
- f_T : Temperature factor
- f_C : Contact factor

•Calculation of service life time(L_h)

If stroke length and repeating time are known, service life time (L_h) can be derived based on rated life (L)

$$L_h = \frac{L \times 10^3}{2 \times l_s \times n_1 \times 60}$$

- L_h : Service life time (hr)
- L : Rated life (km)
- l_s : Stroke length (m)
- n_1 : Rounds per minute (min^{-1})

Calculation of working load

Load effect on a linear guide will be affected by its center of mass, position of thrust and inertia force occurring by acceleration when starting or stopping, etcetera. Therefore, most applications of working conditions must be put into consideration in order to acquire accurate nominal life.

Working load calculation

Type	Operation condition	Load on each block
Horizontal use uniform motion Or at rest		$P_1 = \frac{F}{4} + \frac{Fl_2}{2l_1} - \frac{Fl_4}{2l_2}$ $P_2 = \frac{F}{4} - \frac{Fl_2}{2l_1} - \frac{Fl_4}{2l_2}$ $P_3 = \frac{F}{4} - \frac{Fl_3}{2l_1} + \frac{Fl_4}{2l_2}$ $P_4 = \frac{F}{4} + \frac{Fl_3}{2l_1} + \frac{Fl_4}{2l_2}$
Horizontal cantilever use uniform motion Or at rest		$P_1 = \frac{F}{4} + \frac{Fl_2}{2l_1} + \frac{Fl_3}{2l_2}$ $P_2 = \frac{F}{4} - \frac{Fl_2}{2l_1} + \frac{Fl_3}{2l_2}$ $P_3 = \frac{F}{4} - \frac{Fl_3}{2l_1} - \frac{Fl_2}{2l_2}$ $P_4 = \frac{F}{4} + \frac{Fl_3}{2l_1} - \frac{Fl_2}{2l_2}$
Vertical use uniform motion Or at rest		$P_1 = P_2 = P_3 = P_4 = \frac{Fl_2}{2l_1}$ $P_{11} = P_{21} = P_{31} = P_{41} = \frac{Fl_3}{2l_1}$
Wall-mounted use uniform motion Or at rest		$P_1 = P_2 = P_3 = P_4 = \frac{Fl_2}{2l_1}$ $P_{11} = P_{41} = \frac{F}{4} + \frac{Fl_3}{2l_1}$ $P_{21} = P_{31} = \frac{F}{4} - \frac{Fl_3}{2l_1}$

Linear Guide Selection

Type	Operation condition	Load on each block
Lateral Slope		$P_i = \frac{F \cdot \cos\theta}{4} + \frac{F \cdot \cos\theta \cdot l_i}{2 \cdot l_i} - \frac{F \cdot \cos\theta \cdot l_i}{2 \cdot l_i} + \frac{F \cdot \sin\theta \cdot h_i}{2 \cdot l_i}$ $P_j = \frac{F \cdot \cos\theta}{4} - \frac{F \cdot \cos\theta \cdot l_i}{2 \cdot l_i} - \frac{F \cdot \cos\theta \cdot l_i}{2 \cdot l_i} + \frac{F \cdot \sin\theta \cdot h_i}{2 \cdot l_i}$ $P_{i1} = \frac{F \cdot \cos\theta}{4} - \frac{F \cdot \cos\theta \cdot l_i}{2 \cdot l_i} + \frac{F \cdot \cos\theta \cdot l_i}{2 \cdot l_i} - \frac{F \cdot \sin\theta \cdot h_i}{2 \cdot l_i}$ $P_{j1} = \frac{F \cdot \cos\theta}{4} + \frac{F \cdot \cos\theta \cdot l_i}{2 \cdot l_i} + \frac{F \cdot \cos\theta \cdot l_i}{2 \cdot l_i} - \frac{F \cdot \sin\theta \cdot h_i}{2 \cdot l_i}$ $P_{i1} = P_{j1} = \frac{F \cdot \sin\theta}{4} + \frac{F \cdot \sin\theta \cdot l_i}{2 \cdot l_i}$ $P_{i1} = P_{j1} = \frac{F \cdot \sin\theta}{4} - \frac{F \cdot \sin\theta \cdot l_i}{2 \cdot l_i}$
Axial Slope		$P_i = \frac{F \cdot \cos\theta}{4} + \frac{F \cdot \cos\theta \cdot l_i}{2 \cdot l_i} - \frac{F \cdot \cos\theta \cdot l_i}{2 \cdot l_i} + \frac{F \cdot \sin\theta \cdot h_i}{2 \cdot l_i}$ $P_j = \frac{F \cdot \cos\theta}{4} - \frac{F \cdot \cos\theta \cdot l_i}{2 \cdot l_i} - \frac{F \cdot \cos\theta \cdot l_i}{2 \cdot l_i} - \frac{F \cdot \sin\theta \cdot h_i}{2 \cdot l_i}$ $P_{i1} = \frac{F \cdot \cos\theta}{4} - \frac{F \cdot \cos\theta \cdot l_i}{2 \cdot l_i} + \frac{F \cdot \cos\theta \cdot l_i}{2 \cdot l_i} - \frac{F \cdot \sin\theta \cdot h_i}{2 \cdot l_i}$ $P_{j1} = \frac{F \cdot \cos\theta}{4} + \frac{F \cdot \cos\theta \cdot l_i}{2 \cdot l_i} + \frac{F \cdot \cos\theta \cdot l_i}{2 \cdot l_i} + \frac{F \cdot \sin\theta \cdot h_i}{2 \cdot l_i}$ $P_{i1} = P_{j1} = \frac{F \cdot \sin\theta \cdot l_i}{2 \cdot l_i}$ $P_{i1} = P_{j1} = -\frac{F \cdot \sin\theta \cdot l_i}{2 \cdot l_i}$
Use horizontally with inertial force		<p>When accelerating</p> $P_i = P_j = \frac{mg}{4} + \frac{m \cdot a_i \cdot l_i}{2 \cdot l_i}$ $P_{i1} = P_{j1} = \frac{mg}{4} - \frac{m \cdot a_i \cdot l_i}{2 \cdot l_i}$ <p>When decelerating</p> $P_i = P_j = \frac{mg}{4} - \frac{m \cdot a_i \cdot l_i}{2 \cdot l_i}$ $P_{i1} = P_{j1} = \frac{mg}{4} + \frac{m \cdot a_i \cdot l_i}{2 \cdot l_i}$ <p>At constant speed</p> $P_i = P_j = P_{i1} = P_{j1} = \frac{mg}{4}$
Use vertically with inertial force		<p>When accelerating</p> $P_i = P_j = P_{i1} = P_{j1} = \frac{m \cdot (g + a_i) \cdot l_i}{2 \cdot l_i}$ <p>When decelerating</p> $P_i = P_j = P_{i1} = P_{j1} = \frac{m \cdot (g - a_i) \cdot l_i}{2 \cdot l_i}$ <p>At constant speed</p> $P_i = P_j = P_{i1} = P_{j1} = \frac{mg \cdot l_i}{2 \cdot l_i}$

Linear Guide Selection

Calculation of equivalent load

A block can bear force as well as torque from all axial and radial directions. When multiple loads are applied, these loads can be combined as an equivalent axial and radial load for the calculation of nominal life or static safety factor. Our linear guide can bear loads in four directions, up, down, left, and right. So when using linear slides, it may be subjected to vertical load (P_R) and lateral load (P_T) at the same time. When two or more linear guides are used, the equivalent load (P_E) can be converted according to the following formula.

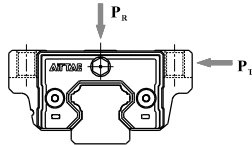

$$P_E = |P_R| + |P_T|$$

- P_E : Equivalent load (N)
- P_R : Radial load (N)
- P_T : Lateral load (N)

In the case of single linear guide, equivalent load must take torque into account, see following formula.

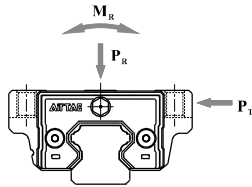

$$P_E = |P_R| + |P_T| + C_0 \frac{|M|}{M_R}$$

- P_E : Equivalent load (N)
- P_R : Radial load (N)
- P_T : Lateral load (N)
- C_0 : Basic static load rating (N)
- M : Calculated torque (N·m)
- M_R : Allowable static moment (N·m)

Calculation of average load

The real-time acting load for a block during movement is always variable. One can derive average load for the use of rated life calculation based on different applications. Average load when rollers are steel ball is as follows:

$$P_m = e \sqrt{\frac{1}{L} \cdot \sum_{i=1}^n (P_i^e \cdot L_i)}$$

- P_m : Average load (N)
- P_i : Variable load (N)
- L : Total Working Distance (mm)
- L_i : Moving distance when load P_i applied (mm)
- e : Exponent (for steel ball: 3)

Average load calculation example

Varying load type	Average load calculation
<p>Interval Variable Load</p>	$P_m = e \sqrt{\frac{1}{L} \cdot (P_1^e \cdot L_1 + P_2^e \cdot L_2 + \dots + P_n^e \cdot L_n)}$ <ul style="list-style-type: none"> P_m : Average load (N) P_n : Variable load (N) L : Total Working Distance (mm) L_n : Moving distance when load P_n applied (mm) e : Exponent (for steel ball: 3)
<p>Monotonic variable load</p>	$P_m \approx \frac{1}{3} (P_{min} + 2 \cdot P_{max})$ <ul style="list-style-type: none"> P_m : Average load (N) P_{min} : Minimum load (N) P_{max} : Maximum load (N)

Linear Guide Selection

Varying load type	Average load calculation
<p>Sinusoidal variable load</p>	$P_m \approx 0.65 \cdot P_{max}$ <p>P_m: Average load (N) P_{max}: Maximum load (N)</p>
	$P_m \approx 0.75 \cdot P_{max}$ <p>P_m: Average load (N) P_{max}: Maximum load (N)</p>

Calculation example

Conditions of Use	Load calculation of each block
<p>Model : LSH30HL2X2520S20BP-M6(2 pcs)</p> <p>Basic dynamic load rating : $C = 45.7 \text{ KN}$</p> <p>Basic static load rating : $C_0 = 73.1 \text{ KN}$</p> <p>Mass $m_1 = 700\text{kg}$ $m_2 = 450\text{kg}$</p> <p>Speed $V = 0.75\text{m/s}$</p> <p>Time $t_1 = 0.05\text{s}$ $t_2 = 1.9\text{s}$ $t_3 = 0.15\text{s}$</p> <p>Acceleration $a_1 = 15\text{m/s}^2$ $a_3 = 5\text{m/s}^2$</p> <p>Travel Distance $l_5 = 1500\text{mm}$</p> <p>Distance $l_1 = 650\text{mm}$ $l_2 = 450\text{mm}$ $l_3 = 135\text{mm}$ $l_4 = 60\text{mm}$ $l_5 = 175\text{mm}$ $l_6 = 400\text{mm}$</p>	<p>At constant speed, the radial load P_n</p> $P_1 = \frac{m_1 \cdot g}{4} - \frac{m_1 \cdot g \cdot l_1}{2l_2} + \frac{m_2 \cdot g \cdot l_2}{2l_1} + \frac{m_2 \cdot g}{4} = 2562\text{N}$ $P_2 = \frac{m_1 \cdot g}{4} + \frac{m_1 \cdot g \cdot l_1}{2l_1} + \frac{m_2 \cdot g \cdot l_4}{2l_2} + \frac{m_2 \cdot g}{4} = 3987\text{N}$ $P_3 = \frac{m_1 \cdot g}{4} + \frac{m_1 \cdot g \cdot l_1}{2l_1} - \frac{m_2 \cdot g \cdot l_2}{2l_2} + \frac{m_2 \cdot g}{4} = 3073\text{N}$ $P_4 = \frac{m_1 \cdot g}{4} - \frac{m_1 \cdot g \cdot l_1}{2l_1} - \frac{m_2 \cdot g \cdot l_4}{2l_2} + \frac{m_2 \cdot g}{4} = 1648\text{N}$ <p>Acceleration is toward left, the radial load $P_n \cdot a_i$</p> $P_1 \cdot a_i = P_1 \cdot \frac{m_1 \cdot a_1 \cdot l_1}{2l_1} - \frac{m_2 \cdot a_1 \cdot l_2}{2l_1} = -1577\text{N}$ $P_2 \cdot a_i = P_2 \cdot \frac{m_1 \cdot a_1 \cdot l_1}{2l_1} + \frac{m_2 \cdot a_1 \cdot l_4}{2l_1} = 8127\text{N}$ $P_3 \cdot a_i = P_3 \cdot \frac{m_1 \cdot a_1 \cdot l_1}{2l_1} + \frac{m_2 \cdot a_1 \cdot l_2}{2l_1} = 7212\text{N}$ $P_4 \cdot a_i = P_4 \cdot \frac{m_1 \cdot a_1 \cdot l_1}{2l_1} - \frac{m_2 \cdot a_1 \cdot l_4}{2l_1} = -2492\text{N}$ <p>Lateral load $P_t \cdot a_i$</p> $P_t \cdot a_i = -\frac{m_1 \cdot a_1 \cdot l_2}{2l_1} = -485\text{N}$ $P_t \cdot a_i = \frac{m_1 \cdot a_1 \cdot l_2}{2l_1} = 485\text{N}$ $P_t \cdot a_i = \frac{m_1 \cdot a_1 \cdot l_2}{2l_1} = 485\text{N}$ $P_t \cdot a_i = -\frac{m_1 \cdot a_1 \cdot l_2}{2l_1} = -485\text{N}$

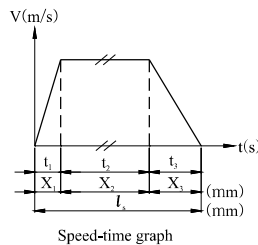
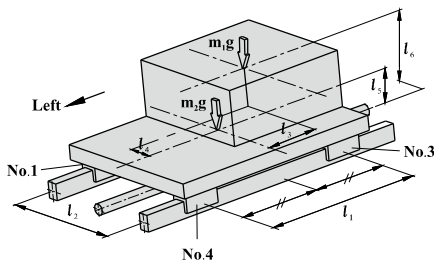

Conditions of Use

Model : LSH30HL2X2520S20BP-M6(2 pcs)
 Basic dynamic load rating : $C=45.7 \text{ KN}$
 Basic static load rating : $C_0=73.1 \text{ KN}$
 Mass $m_1=700\text{kg}$ $m_2=450\text{kg}$
 Speed $V=0.75\text{m/s}$
 Time $t_1=0.05\text{s}$ $t_2=1.9\text{s}$ $t_3=0.15\text{s}$
 Acceleration $a_1=15\text{m/s}^2$ $a_3=5\text{m/s}^2$
 Travel Distance $l_3=1500\text{mm}$
 Distance $l_1=650\text{mm}$ $l_2=450\text{mm}$ $l_3=135\text{mm}$ $l_4=60\text{mm}$ $l_5=175\text{mm}$ $l_6=400\text{mm}$

Load calculation of each block

Deceleration is toward left, the radial load $P_{r1}a_3$

$$P_{r1}a_3 = P_1 + \frac{m_1 \cdot a_1 \cdot l_6}{2l_1} + \frac{m_2 \cdot a_1 \cdot l_5}{2l_1} = 3942\text{N}$$

$$P_{r2}a_3 = P_2 - \frac{m_1 \cdot a_1 \cdot l_6}{2l_1} - \frac{m_2 \cdot a_1 \cdot l_5}{2l_1} = 2607\text{N}$$

$$P_{r3}a_3 = P_3 - \frac{m_1 \cdot a_1 \cdot l_6}{2l_1} - \frac{m_2 \cdot a_1 \cdot l_5}{2l_1} = 1693\text{N}$$

$$P_{r4}a_3 = P_4 + \frac{m_1 \cdot a_1 \cdot l_6}{2l_1} + \frac{m_2 \cdot a_1 \cdot l_5}{2l_1} = 3028\text{N}$$

Lateral load $P_{t1}a_3$

$$P_{t1}a_3 = \frac{m_1 \cdot a_1 \cdot l_4}{2l_1} = 162\text{N}$$

$$P_{t2}a_3 = -\frac{m_1 \cdot a_1 \cdot l_4}{2l_1} = -162\text{N}$$

$$P_{t3}a_3 = -\frac{m_1 \cdot a_1 \cdot l_4}{2l_1} = -162\text{N}$$

$$P_{t4}a_3 = \frac{m_1 \cdot a_1 \cdot l_4}{2l_1} = 162\text{N}$$

Acceleration is toward right, the radial load $P_{r1}a_1$

$$P_{r1}a_1 = P_1 + \frac{m_1 \cdot a_1 \cdot l_6}{2l_1} + \frac{m_2 \cdot a_1 \cdot l_5}{2l_1} = 6702\text{N}$$

$$P_{r2}a_1 = P_2 - \frac{m_1 \cdot a_1 \cdot l_6}{2l_1} - \frac{m_2 \cdot a_1 \cdot l_5}{2l_1} = -152\text{N}$$

$$P_{r3}a_1 = P_3 - \frac{m_1 \cdot a_1 \cdot l_6}{2l_1} - \frac{m_2 \cdot a_1 \cdot l_5}{2l_1} = -1067\text{N}$$

$$P_{r4}a_1 = P_4 + \frac{m_1 \cdot a_1 \cdot l_6}{2l_1} + \frac{m_2 \cdot a_1 \cdot l_5}{2l_1} = 5787\text{N}$$

Lateral load $P_{t1}a_1$

$$P_{t1}a_1 = \frac{m_1 \cdot a_1 \cdot l_4}{2l_1} = 485\text{N}$$

$$P_{t2}a_1 = -\frac{m_1 \cdot a_1 \cdot l_4}{2l_1} = -485\text{N}$$

$$P_{t3}a_1 = -\frac{m_1 \cdot a_1 \cdot l_4}{2l_1} = -485\text{N}$$

$$P_{t4}a_1 = \frac{m_1 \cdot a_1 \cdot l_4}{2l_1} = 485\text{N}$$

Deceleration is toward right, the radial load $P_{r1}a_3$

$$P_{r1}a_3 = P_1 - \frac{m_1 \cdot a_1 \cdot l_6}{2l_1} - \frac{m_2 \cdot a_1 \cdot l_5}{2l_1} = 1183\text{N}$$

$$P_{r2}a_3 = P_2 + \frac{m_1 \cdot a_1 \cdot l_6}{2l_1} + \frac{m_2 \cdot a_1 \cdot l_5}{2l_1} = 5367\text{N}$$

$$P_{r3}a_3 = P_3 + \frac{m_1 \cdot a_1 \cdot l_6}{2l_1} + \frac{m_2 \cdot a_1 \cdot l_5}{2l_1} = 4452\text{N}$$

$$P_{r4}a_3 = P_4 - \frac{m_1 \cdot a_1 \cdot l_6}{2l_1} - \frac{m_2 \cdot a_1 \cdot l_5}{2l_1} = 268\text{N}$$

Lateral load $P_{t1}a_3$

$$P_{t1}a_3 = -\frac{m_1 \cdot a_1 \cdot l_4}{2l_1} = -162\text{N}$$

$$P_{t2}a_3 = \frac{m_1 \cdot a_1 \cdot l_4}{2l_1} = 162\text{N}$$

$$P_{t3}a_3 = \frac{m_1 \cdot a_1 \cdot l_4}{2l_1} = 162\text{N}$$

$$P_{t4}a_3 = -\frac{m_1 \cdot a_1 \cdot l_4}{2l_1} = -162\text{N}$$

Equivalent load calculation

At constant speed

$$P_{e1} = P_1 = 2562\text{N}$$

$$P_{e2} = P_2 = 3987\text{N}$$

$$P_{e3} = P_3 = 3073\text{N}$$

$$P_{e4} = P_4 = 1648\text{N}$$

When acceleration is toward left

$$P_{e1}a_1 = |P_{r1}a_1| + |P_{t1}a_1| = 2062\text{N}$$

$$P_{e2}a_1 = |P_{r2}a_1| + |P_{t2}a_1| = 8611\text{N}$$

$$P_{e3}a_1 = |P_{r3}a_1| + |P_{t3}a_1| = 7697\text{N}$$

$$P_{e4}a_1 = |P_{r4}a_1| + |P_{t4}a_1| = 2976\text{N}$$

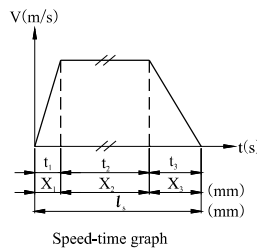
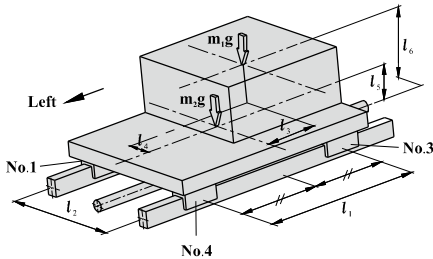

Linear Guide Selection

Conditions of Use

Model : LSH30HL2X2520S20BP-M6(2 pcs)

Basic dynamic load rating : $C=45.7 \text{ KN}$

Basic static load rating : $C_0=73.1 \text{ KN}$

Mass $m_1=700\text{kg}$ $m_2=450\text{kg}$

Speed $V=0.75\text{m/s}$

Time $t_1=0.05\text{s}$ $t_2=1.9\text{s}$ $t_3=0.15\text{s}$

Acceleration $a_1=15\text{m/s}^2$ $a_3=5\text{m/s}^2$

Travel Distance $l_s=1500\text{mm}$

Distance $l_1=650\text{mm}$ $l_2=450\text{mm}$ $l_3=135\text{mm}$ $l_4=60\text{mm}$ $l_5=175\text{mm}$ $l_6=400\text{mm}$

Equivalent load calculation

When deceleration is toward left

$$P_{E1}l_{a1} = |P_1l_{a1}| + |Pt_1l_{a1}| = 4104N$$

$$P_{E2}l_{a2} = |P_2l_{a1}| + |Pt_2l_{a1}| = 2769N$$

$$P_{E3}l_{a3} = |P_3l_{a1}| + |Pt_3l_{a1}| = 1854N$$

$$P_{E4}l_{a4} = |P_4l_{a1}| + |Pt_4l_{a1}| = 3189N$$

When acceleration is toward right

$$P_{E1}r_{a1} = |P_1r_{a1}| + |Pt_1r_{a1}| = 7186N$$

$$P_{E2}r_{a2} = |P_2r_{a1}| + |Pt_2r_{a1}| = 637N$$

$$P_{E3}r_{a3} = |P_3r_{a1}| + |Pt_3r_{a1}| = 1551N$$

$$P_{E4}r_{a4} = |P_4r_{a1}| + |Pt_4r_{a1}| = 6272N$$

When deceleration is toward right

$$P_{E1}r_{a5} = |P_1r_{a5}| + |Pt_1r_{a5}| = 1344N$$

$$P_{E2}r_{a5} = |P_2r_{a5}| + |Pt_2r_{a5}| = 5529N$$

$$P_{E3}r_{a5} = |P_3r_{a5}| + |Pt_3r_{a5}| = 4614N$$

$$P_{E4}r_{a5} = |P_4r_{a5}| + |Pt_4r_{a5}| = 430N$$

Calculation of static safety factor

We now know that the maximum equivalent load occurs on No.2 slider. Therefore, one can calculate static safety factor based on it in following formula

$$f_s = \frac{C_0}{P_{E2}l_{a1}} = \frac{73.1 \times 10^3}{8611} = 8.49$$

Calculation of the average load of each slider P_m

$$P_{m1} = \sqrt[3]{\frac{(P_{E1}l_{a1}^2X_1 + P_{E1}^2X_2 + P_{E1}l_{a1}^2X_3 + P_{E1}r_{a1}^2X_4 + P_{E1}^2X_5 + P_{E1}r_{a1}^2X_6)}{2l_s}} = 2701N$$

$$P_{m2} = \sqrt[3]{\frac{(P_{E2}l_{a1}^2X_1 + P_{E2}^2X_2 + P_{E2}l_{a1}^2X_3 + P_{E2}r_{a1}^2X_4 + P_{E2}^2X_5 + P_{E2}r_{a1}^2X_6)}{2l_s}} = 4077N$$

$$P_{m3} = \sqrt[3]{\frac{(P_{E3}l_{a1}^2X_1 + P_{E3}^2X_2 + P_{E3}l_{a1}^2X_3 + P_{E3}r_{a1}^2X_4 + P_{E3}^2X_5 + P_{E3}r_{a1}^2X_6)}{2l_s}} = 3188N$$

$$P_{m4} = \sqrt[3]{\frac{(P_{E4}l_{a1}^2X_1 + P_{E4}^2X_2 + P_{E4}l_{a1}^2X_3 + P_{E4}r_{a1}^2X_4 + P_{E4}^2X_5 + P_{E4}r_{a1}^2X_6)}{2l_s}} = 1873N$$

Calculation of rated life L_n

Assuming $f_s=1.5$ and according to rated life formula, the rated life can be calculated as follows:

$$L_1 = \left(\frac{C}{f_s P_{m1}}\right)^3 \times 50 = 71758Km \quad L_2 = \left(\frac{C}{f_s P_{m2}}\right)^3 \times 50 = 43641Km$$

$$L_3 = \left(\frac{C}{f_s P_{m3}}\right)^3 \times 50 = 20865Km \quad L_4 = \left(\frac{C}{f_s P_{m4}}\right)^3 \times 50 = 215195Km$$

Calculation conclusion

Choose the minimum from four sliders to represent rated life, which is 20865 Km on No.2 slider

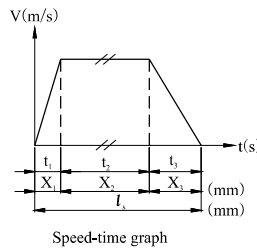
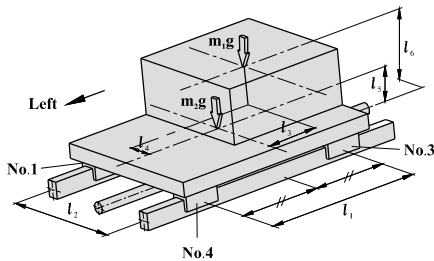

Preload and rigidity

Preload spec can be applied to enhance rigidity. As the graph shows on the right, the effectiveness of preload can maintain until external load reaches 2.8 times of preload strength. In other words, rigidity increases 2.8 times. Preload is applied by choosing bigger diameter of rollers to increase interference between rollers and groove and raise initial loads. Therefore when calculating rated life, preload should be put into consideration.

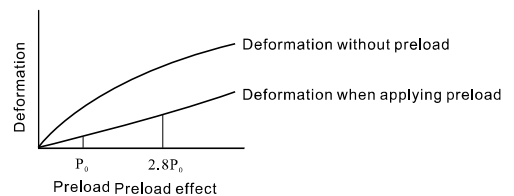



LSH Series Standard Type Linear Guide

Product Introduction

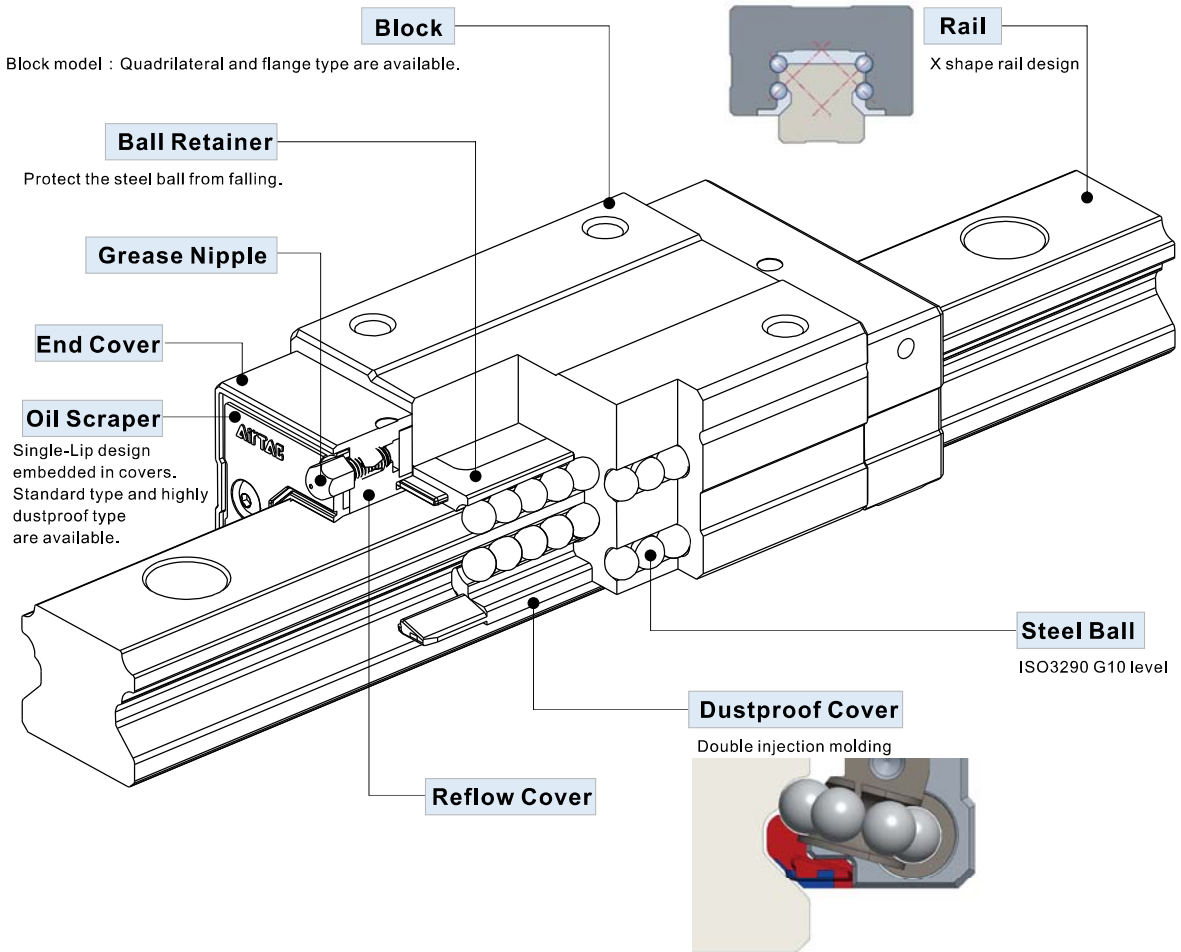

Product Features

1. With self-adjustment ability

X-shaped (45° - 45°) of curved groove on cross section design makes it self-aligning. Even small misalignment exists on the mounting surface, this design can help absorb it and maintain high precision, smooth and stable linear motion.

2. High rigidity, equal load on four direction design

The 45-degree contact angle design of the four rows of steel balls and the raceway allow the steel balls to achieve the ideal two-point contact, and can withstand the action and reaction force from the radial and lateral direction. Meanwhile, pre-load can be applied to increase extra rigidity if necessary.

3. Interchangeable

Because of the strict control on manufacturing process, the dimensional accuracy is stable and within the set tolerance. Besides the ball retainer design can prevent steel balls from falling out. Therefore when assembling, blocks are interchangeable within the same spec and still maintain consistency of pre-load and accuracy.



Standard Type Linear Guide



LSH Series



Order Information(Combined)

LSH □ 15 H N 1 X220 S20 A H - AM6 - B - T

① ② ③ ④ ⑤ ⑥ ⑦ ⑧ ⑨ ⑩ ⑪ ⑫ ⑬

① Model Code	LSH:Standard Type Linear Guide																																							
② Rail&Block surface treatment	Blank: without additional coating. (natural color) ★BB : Block and rail coated with black chrome																																							
③ Rail Width	15: 15mm 20: 20mm 25: 23mm 30: 28mm 35: 34mm 45: 45mm																																							
④ Block Style	H: Square type F1: Flange type, Mounting from top F2: Flange type, Mounting from bottom F3: Flange type, Mounting from top or bottom																																							
⑤ Block type	N: Standard L: Long [w/o 15 series]																																							
⑥ Number of Block	1: One 2: Two [Note: Amount of block on a single set of linear guide]																																							
⑦ Length of Rail	220:220mm[Defined by customer]																																							
⑧ Position of first mounting hole	S□ : Distance from end of rail to the center of first mounting hole (It is recommended to be greater than minimum margin)																																							
⑨ Preload	A: Standard clearance B: Light Preload C: Medium Preload D: Heavy Preload																																							
⑩ Accuracy	N : Normal H : High P : Precision																																							
⑪ Nipple /adapter type	<table border="1"> <tr> <td>M4: M4 Nipple</td> <td></td> <td>M6: M6 Nipple</td> <td></td> <td>P01: PT1/8 Nipple</td> <td></td> </tr> <tr> <td>AM6: M4 to M6</td> <td></td> <td>A01: M6 to PT1/8</td> <td></td> <td>A01: PT1/8 to PT1/8</td> <td></td> </tr> <tr> <td></td> <td></td> <td>AM8: M6 to M8</td> <td></td> <td>AM8: PT1/8 to M8</td> <td></td> </tr> <tr> <td></td> <td></td> <td>L01: M6 to PT1/8</td> <td></td> <td>L01: PT1/8 to PT1/8</td> <td></td> </tr> <tr> <td>LM6: M4 to M6</td> <td></td> <td>LM8: M6 to M8</td> <td></td> <td>LM8: PT1/8 to M8</td> <td></td> </tr> <tr> <td></td> <td></td> <td>SM6: M6 Nipple</td> <td></td> <td>SP01: PT1/8 Nipple</td> <td></td> </tr> </table>	M4: M4 Nipple		M6: M6 Nipple		P01: PT1/8 Nipple		AM6: M4 to M6		A01: M6 to PT1/8		A01: PT1/8 to PT1/8				AM8: M6 to M8		AM8: PT1/8 to M8				L01: M6 to PT1/8		L01: PT1/8 to PT1/8		LM6: M4 to M6		LM8: M6 to M8		LM8: PT1/8 to M8				SM6: M6 Nipple		SP01: PT1/8 Nipple				
M4: M4 Nipple		M6: M6 Nipple		P01: PT1/8 Nipple																																				
AM6: M4 to M6		A01: M6 to PT1/8		A01: PT1/8 to PT1/8																																				
		AM8: M6 to M8		AM8: PT1/8 to M8																																				
		L01: M6 to PT1/8		L01: PT1/8 to PT1/8																																				
LM6: M4 to M6		LM8: M6 to M8		LM8: PT1/8 to M8																																				
		SM6: M6 Nipple		SP01: PT1/8 Nipple																																				
⑫ Packing type	Blank: the block and rail are assembled B: block and rail are put separately																																							
⑬ Rail type	Blank: Top-mount T: Bottom-mount																																							

- ★[Note 1] Dustproof standard type please refer to Pg. 26. for more detail.
- ★[Note 2] Self-lubricator standard type please refer to Pg. 30. for more detail.
- [Note 3] For LSH-BB series, standard length of a rail is 3 m.
Please contact with our company if length of rail exceeds the maximum.
Add: Heavy preload is available for LSH25/30/35/45 only.



LSH Series

Butt-jointed Order Information

LSH □ 15 H N 1X2970 T 2940 T 2970 A H - AM6-B - T

① ② ③ ④ ⑤ ⑥ ⑦ ⑧ ⑨ ⑩ ⑪ ⑫ ⑬ ⑭ ⑮ ⑯

① Model Code	LSH:Standard Type Linear Guide																			
② Rail&Block surface treatment	Blank: without additional coating. (natural color) ★BB : Block and rail coated with black chrome																			
③ Rail Width	15: 15mm 20: 20mm 25: 23mm 30: 28mm 35: 34mm 45: 45mm																			
④ Block Style	H: Square type F1: Flange type, Mounting from top F2: Flange type, Mounting from bottom F3: Flange type, Mounting from top or bottom																			
⑤ Block type	N: Standard L: Long [w/o 15 series]																			
⑥ Number of Block	1: One 2: Two [Note: Amount of block on a single set of linear guide]																			
⑦ Length of first Rail	2970:2970mm[Defined by customer]																			
⑧ Butt-jointed mark	T: Rail Butt-jointed mark (Butt-jointed end margin:1/2P) [P is the standard hole distance]																			
⑨ Length of second Rail	2940:2940mm[Defined by customer]																			
⑩ Butt-jointed mark	Blank: two rails joint T: Rail Butt-jointed mark (Butt-jointed end margin:1/2P) [P is the standard hole distance]																			
⑪ Length of third Rail	Blank: two rails joint 2970:2970mm.....[Defined by customer]																			
⑫ Preload	A: Standard clearance B: Light Preload C: Medium Preload D: Heavy Preload																			
⑬ Accuracy	N : Normal H : High																			
⑭ Nipple /adapter type	<table border="1"> <tr> <td>M4: M4 Nipple</td> <td>M6: M6 Nipple</td> <td>P01: PT1/8 Nipple</td> </tr> <tr> <td>I type</td> <td>A01: M6 to PT1/8 I type</td> <td>A01: PT1/8 to PT1/8 I type</td> </tr> <tr> <td>AM6: M4 to M6</td> <td>20 AM8: M6 to M8</td> <td>AM8: PT1/8 to M8</td> </tr> <tr> <td>15 L type</td> <td>30 L01: M6 to PT1/8 L type</td> <td>L01: PT1/8 to PT1/8 L type</td> </tr> <tr> <td>LM6: M4 to M6</td> <td>35 LM8: M6 to M8</td> <td>LM8: PT1/8 to M8</td> </tr> <tr> <td></td> <td>SM6: M6 Nipple</td> <td>SP01: PT1/8 Nipple</td> </tr> </table>		M4: M4 Nipple	M6: M6 Nipple	P01: PT1/8 Nipple	I type	A01: M6 to PT1/8 I type	A01: PT1/8 to PT1/8 I type	AM6: M4 to M6	20 AM8: M6 to M8	AM8: PT1/8 to M8	15 L type	30 L01: M6 to PT1/8 L type	L01: PT1/8 to PT1/8 L type	LM6: M4 to M6	35 LM8: M6 to M8	LM8: PT1/8 to M8		SM6: M6 Nipple	SP01: PT1/8 Nipple
M4: M4 Nipple	M6: M6 Nipple	P01: PT1/8 Nipple																		
I type	A01: M6 to PT1/8 I type	A01: PT1/8 to PT1/8 I type																		
AM6: M4 to M6	20 AM8: M6 to M8	AM8: PT1/8 to M8																		
15 L type	30 L01: M6 to PT1/8 L type	L01: PT1/8 to PT1/8 L type																		
LM6: M4 to M6	35 LM8: M6 to M8	LM8: PT1/8 to M8																		
	SM6: M6 Nipple	SP01: PT1/8 Nipple																		
⑮ Packing type	Blank: the block and rail are assembled B: block and rail are put separately																			
⑯ Rail type	Blank: Top-mount T: Bottom-mount																			

Butt-jointed end margin:1/2P ,
Position of the first and last hole is defined by customer.

- ★ [Note 1] Dustproof standard type please refer to Pg. 26. for more detail.
- ★ [Note 2] Self-lubricator standard type please refer to Pg. 30. for more detail.

[Note 3] For LSH-BB series, standard length of a rail is 3 m.

Maximum length of two-joint rail is 6 m.

Maximum length of three-joint rail is 9 m.

Please contact with our company

if length of rail exceeds the maximum.

Add1: Number of joints cannot be more than 2 times(three rails at most).

For LSH15/20/25, maximum length of jointed rail is 11800mm.

For LSH30/35, it's 11880. For LSH45, it's 11805.

Customization is needed for joint times more than standard.

Add2: Heavy preload is available for LSH25/30/35/45 only.

LSH Series

1. Block Order Information

LSH □ 15 BK-H N-H-E-AM6

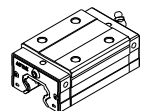

N: Standard

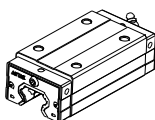

L: Long

① Model Code	LSH: Standard Type Linear Guide		
② Coating on block	Blank: Block without additional coating. (natural color) ★B: Block coated with black chrome		
③ Rail Width	15: 15mm 20: 20mm 25: 23mm 30: 28mm 35: 34mm 45: 45mm		
④ Block Code	BK: Block		
⑤ Block Style	H: Square type F1: Flange type, Mounting from top F2: Flange type, Mounting from bottom F3: Flange type, Mounting from top or bottom		
⑥ Block type	N: Standard L: Long [w/o 15 series]		
⑦ Accuracy	N: Normal H: High		
⑧ Group code	SA SB SC SE SF B C E [Note1]		
⑨ Nipple /adapter type	M4: M4 Nipple		
	M6: M6 Nipple		
	M4 to M6		
	M6 to M8		
	M8 to M6		
	M6 to M4		

★ [Note 1] Dustproof standard type please refer to Pg. 26. for more detail.

★ [Note 2] Self-lubricator standard type please refer to Pg. 30. for more detail.

Add: When selecting rails and bearings, the different pairing codes can change the units preload. details see "preload pairing chart".

2. Rail(4m) Order Information

LSH 15 RL X 4000-H - E - T

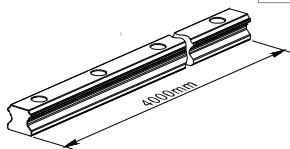

① Model Code	LSH: Standard Type Linear Guide		
② Rail Width	15: 15mm 20: 20mm 25: 23mm 30: 28mm 35: 34mm 45: 45mm		
③ Rail Code	RL: Rail		
④ Rail Length	4000 : 4000mm		
⑤ Accuracy	N : Normal H : High		
⑥ Group code	E [Note]		
⑦ Rail type	Blank: Top-mount T: Bottom-mount		

Note: ● Standard length of LSH rail is four meters.

● For LSH15/20/25, both margin pitch of rail are 20mm.

● For LSH30/35, one side of margin pitch is 20mm, the other side is 60mm.

● For LSH45, one side of margin pitch is 22.5mm, the other side is 92.5mm.

● When selecting rails and bearings, the different pairing codes can change the units preload. details see "preload pairing chart".

3. Rail Order Information

LSH □ 15 RL X 220 - S20 - H - E - T

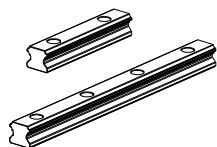

① Model Code	LSH: Standard Type Linear Guide		
② Coating on rail	Blank: Rail without additional coating. (natural color) ★B: Rail coated with black chrome		
③ Rail Width	15: 15mm 20: 20mm 25: 23mm 30: 28mm 35: 34mm 45: 45mm		
④ Rail Code	RL: Rail		
⑤ Rail Length	220:220mm[Defined by the customer]		
⑥ Position of first mounting hole	S□ : Distance from end of rail to the center of first mounting hole (It is recommended to be greater than minimum margin)		
⑦ Accuracy	N : Normal H : High		
⑧ Group code	E [Note]		
⑨ Rail type	Blank: Top-mount T: Bottom-mount		

Note: 1. When selecting rails and bearings, the different pairing codes can change the units preload. details see "preload pairing chart".

2. For LSH-B series, standard length of a rail is 3 m.

LSH Series

4. Rail/Block preload pairing chart

When customer orders rail/block, please choose the pairing code of rail/block in accordance with the needed preload of linear guide(combined). Details please refer to the "preload pairing chart".

Model	Rail pairing code	Block pairing code	Preload grade	Model	Rail pairing code	Block pairing code	Preload grade
LSH15 LSH20	E	E	Standard clearance	LSH25	E	E	Standard clearance
		C	Light preload			C	Light preload
		SA	Medium preload			SB	Medium preload
		SE	Heavy Preload				
Model	Rail pairing code	Block pairing code	Preload grade	Model	Rail pairing code	Block pairing code	Preload grade
LSH30	E	E	Standard clearance	LSH35 LSH45	E	E	Standard clearance
		C	Light preload			B	Light preload
		SC	Medium preload			SC	Medium preload
		SF	Heavy Preload			SF	Heavy Preload

Accessory Order Code

L - P - AM6 - □

① ② ③ ④

① Accessory Code	L: Linear Guide Accessory			
② Nipple/adaptor Code	P: Nipple/adaptor			
③ Nipple/adaptor type	M4: M4 Nipple	Nipple	M6: M6 Nipple	Nipple
	AM6: M4 to M6	I type	SM6: M6 Nipple	I type
	LM6: M4 to M6	L type	A01: M6 to PT1/8	I type
			AM8: M6 to M8	L type
	L01: M6 to PT1/8			
	LM8: M6 to M8			
④ Block type	Blank: Standard		ZZ: High dustproof block(both DD and ZZ type)	

Rail (4m) Specification

1. The maximum length of a single rail is 4,000 mm, please refer to the table for more detail about edge pitch of first mounting hole (S) and last mounting hole (E).

2. The edge pitch of first mounting hole (S) and last mounting hole (E) should not be greater than 1/2P. Overlong edge may induce unstable installation and affect the accuracy.

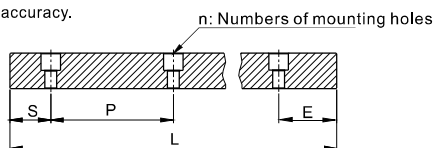

$$L = (n-1) \times P + S + E$$

L: Total length of rail(mm)

n: Numbers of mounting holes on rail

P: Distance between bolt holes(mm)

S: Edge of first mounting hole(mm)

E: Edge of last mounting hole(mm)

Model	LSH15	LSH20	LSH25	LSH30	LSH35	LSH45
Pitch(P)	60	60	60	80	80	105
Rail (4m) Standard Edge Pitch(S)	20	20	20	20	20	22.5
Rail (4m) Standard Edge Pitch(E)	20	20	20	60	60	92.5
Min. Edge Pitch(S/E min)	5	6	7	8	8	11
Max. Edge Pitch(S/E max)	55	54	53	72	72	94
Maximum length(Lmax)	4000	4000	4000	4000	4000	4000

Note:

- Joint rail must be chosen if length of rail exceeds the maximum.
- When deciding edge pitch, it should be within the range of above table. There would be risk of broken hole if pitch is out of range.
- Maximum length of rail for standard' means the maximum length of rail can be chosen when both sides of edge pitches are standard.

LSH Series

Specifications and Dimensions

Square type

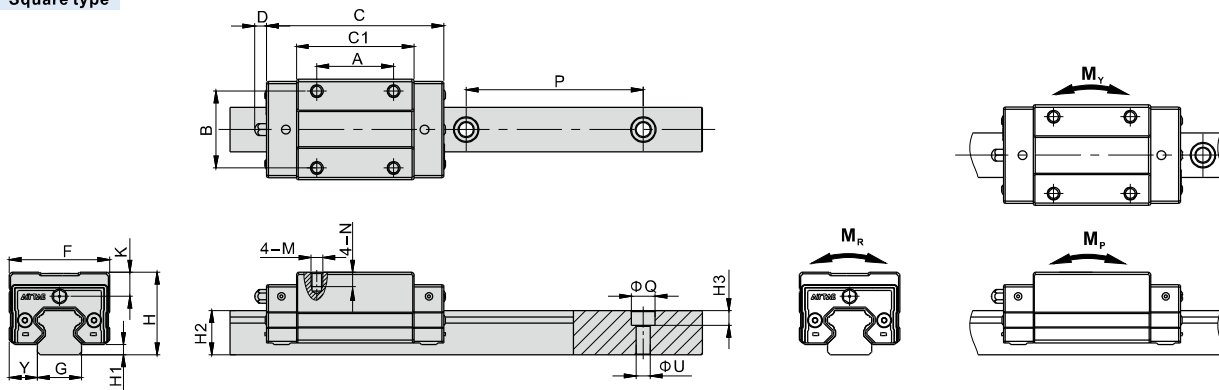

Model/Item	External Dimension (mm)							Block Dimension (mm)							Rail Dimension (mm)					
	H	H1	F	Y	C			C1	A	B	K	D	M	N	G	H2	P	ΦQ	ΦU	H3
					Standard (Blank)	Double oil scrapers(DD)	Oil scraper+Metal scraper(ZZ)													
LSH15HN	28	3.5	34	9.5	60	67	64.5	40	26	26	8.3	6	M4X0.7	5	15	15	60	8	4.8	5.3
LSH20HN	30	4.3	44	12	76.5	84.5	81	52	36	32	6.5	12.5	M5X0.8	6	20	17.5	60	9.5	5.8	8.5
LSH20HL	30	4.3	44	12	90.5	98.5	95	66	50	32	6.5	12.5	M5X0.8	6	20	17.5	60	9.5	5.8	8.5
LSH25HN	40	6.5	48	12.5	83.5	91.5	88	58.5	35	35	10.9	12.5	M6X1.0	8	23	22	60	11.2	7	9
LSH25HL	40	6.5	48	12.5	105	113	109.5	80	50	35	10.9	12.5	M6X1.0	8	23	22	60	11.2	7	9
LSH30HN	45	6.5	60	16	95.5	103.5	100.5	70.5	40	40	11	13	M8X1.25	10	28	26	80	14.2	9	12
LSH30HL	45	6.5	60	16	118	126	123	93	60	40	11	13	M8X1.25	10	28	26	80	14.2	9	12
LSH35HN	55	7	70	18	109	118	114	80	50	50	16.2	12.5	M8X1.25	12	34	29	80	14.2	9	12
LSH35HL	55	7	70	18	134.5	143.5	139.5	105.5	72	50	16.2	12.5	M8X1.25	12	34	29	80	14.2	9	12
LSH45HN	70	10	86	20.5	132	141	137	98	60	60	20	16	M10X1.5	17	45	38	105	20	14	17
LSH45HL	70	10	86	20.5	164	173	169	130	80	60	20	16	M10X1.5	17	45	38	105	20	14	17

Model/Item	Mounting Screw	Dynamic Load Rating(kN)	Static Load Rating(kN)	Static Rated Moment (kN.m)			Weight	
		C	C ₀	M _R	M _P	M _Y	Block(kg)	Rail(kg/m)
LSH15HN	M4	11.3	17.9	0.12	0.12	0.12	0.2	1.43
LSH20HN	M5	18.6	28.6	0.27	0.25	0.25	0.33	2.23
LSH20HL	M5	22.2	37.6	0.35	0.34	0.34	0.41	2.23
LSH25HN	M6	26.9	39.4	0.44	0.38	0.38	0.53	3.32
LSH25HL	M6	32.9	53.0	0.58	0.57	0.57	0.7	3.32
LSH30HN	M8	37.4	55.0	0.66	0.67	0.67	0.91	4.5
LSH30HL	M8	45.7	73.1	0.88	0.91	0.91	1.17	4.5
LSH35HN	M8	50.8	72.3	1.05	0.92	0.92	1.26	6.37
LSH35HL	M8	61.9	96.1	1.52	1.45	1.45	1.68	6.37
LSH45HN	M12	80.7	110.3	1.95	1.62	1.62	2.72	10.7
LSH45HL	M12	98.5	146.9	2.59	2.92	2.92	3.60	10.7

LSH Series

Flange type, Top-Mount

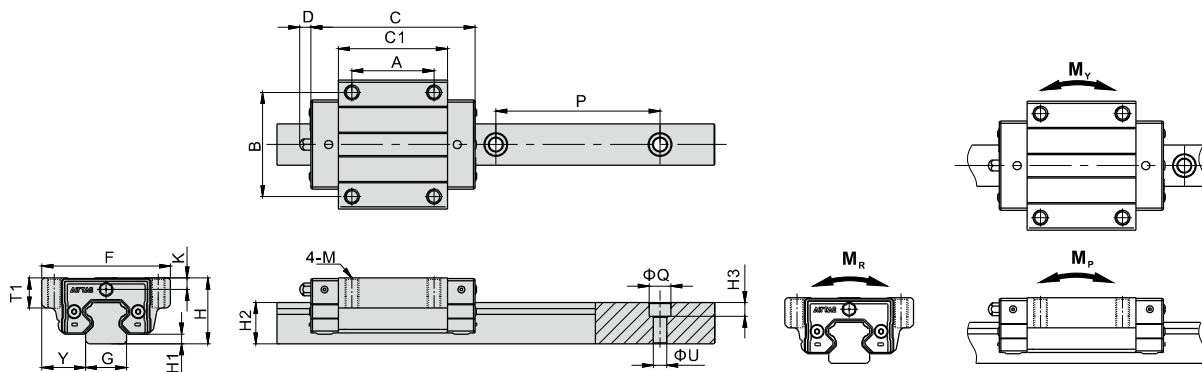

Model/Item	External Dimension (mm)							Block Dimension (mm)						Rail Dimension (mm)						
	H	H1	F	Y	C			C1	A	B	K	D	M	T1	G	H2	P	ΦQ	ΦU	H3
					Standard (Blank)	Double oil scrapers(DD)	Oil scraper+Metal scraper(ZZ)													
LSH15F1N	24	3.5	47	16	60	67	64.5	40	30	38	4.3	6	M5X0.8	11	15	15	60	8	4.8	5.3
LSH20F1N	30	4.3	63	21.5	76.5	84.5	81	52	40	53	6.5	12.5	M6X1.0	10	20	17.5	60	9.5	5.8	8.5
LSH20F1L	30	4.3	63	21.5	90.5	98.5	95	66	40	53	6.5	12.5	M6X1.0	10	20	17.5	60	9.5	5.8	8.5
LSH25F1N	36	6.5	70	23.5	83.5	91.5	88	58.5	45	57	6.9	12.5	M8X1.25	16	23	22	60	11.2	7	9
LSH25F1L	36	6.5	70	23.5	105	113	109.5	80	45	57	6.9	12.5	M8X1.25	16	23	22	60	11.2	7	9
LSH30F1N	42	6.5	90	31	95.5	103.5	100.5	70.5	52	72	8	13	M10X1.5	18	28	26	80	14.2	9	12
LSH30F1L	42	6.5	90	31	118	126	123	93	52	72	8	13	M10X1.5	18	28	26	80	14.2	9	12
LSH35F1N	48	7	100	33	109	118	114	80	62	82	9.2	12.5	M10X1.5	21	34	29	80	14.2	9	12
LSH35F1L	48	7	100	33	134.5	143.5	139.5	105.5	62	82	9.2	12.5	M10X1.5	21	34	29	80	14.2	9	12
LSH45F1N	60	10	120	37.5	132	141	137	98	80	100	10	16	M12X1.75	22	45	38	105	20	14	17
LSH45F1L	60	10	120	37.5	164	173	169	130	80	100	10	16	M12X1.75	22	45	38	105	20	14	17

Model/Item	Mounting Screw	Dynamic Load Rating(kN)	Static Load Rating(kN)	Static Rated Moment (kN.m)			Weight	
				Mr	Mp	Mv	Block(kg)	Rail(kg/m)
LSH15F1N	M4	11.3	17.9	0.12	0.12	0.12	0.2	1.43
LSH20F1N	M5	18.6	28.6	0.27	0.25	0.25	0.40	2.23
LSH20F1L	M5	22.2	37.6	0.35	0.34	0.34	0.8	2.23
LSH25F1N	M6	26.9	39.4	0.44	0.38	0.38	0.59	3.32
LSH25F1L	M6	32.9	53.0	0.58	0.57	0.57	0.85	3.32
LSH30F1N	M8	37.4	55.0	0.66	0.67	0.67	1.09	4.5
LSH30F1L	M8	45.7	73.1	0.88	0.91	0.91	1.38	4.5
LSH35F1N	M8	50.8	72.3	1.05	0.92	0.92	1.32	6.37
LSH35F1L	M8	61.9	96.1	1.52	1.45	1.45	1.8	6.37
LSH45F1N	M12	80.7	110.3	1.95	1.62	1.62	2.77	10.7
LSH45F1L	M12	98.5	146.9	2.59	2.92	2.92	3.67	10.7

Standard Type Linear Guide

LSH Series

Flange type, Bottom-Mount

Flange type, Top or Bottom-Mount

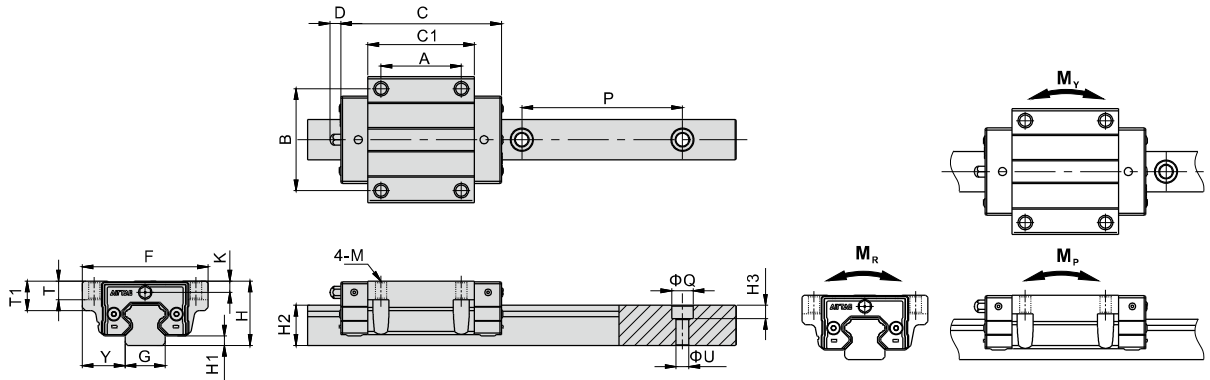

Model/Item	External Dimension(mm)							Block Dimension(mm)							Rail Dimension(mm)							
	H	H1	F	Y	C			C1	A	B	K	D	M		T	T1	G	H2	P	ΦQ	ΦU	H3
					Standard (Blank)	Double oil scrapers(DD)	Oil scraper+Metal scraper(ZZ)						Bottom-Mount	Top or Bottom-Mount								
LSH15F2(F3)N	24	3.5	47	16	60	67	64.5	40	30	38	4.3	6	Φ4.5	M5X0.8	7	11	15	15	60	8	4.8	5.3
LSH20F2(F3)N	30	4.3	63	21.5	76.5	84.5	81	52	40	53	6.5	12.5	Φ5.7	M6X1.0	9.5	10	20	17.5	60	9.5	5.8	8.5
LSH20F2(F3)L	30	4.3	63	21.5	90.5	98.5	95	66	40	53	6.5	12.5	Φ5.7	M6X1.0	9.5	10	20	17.5	60	9.5	5.8	8.5
LSH25F2(F3)N	36	6.5	70	23.5	83.5	91.5	88	58.5	45	57	6.9	12.5	Φ6.8	M8X1.25	10	16	23	22	60	11.2	7	9
LSH25F2(F3)L	36	6.5	70	23.5	105	113	109.5	80	45	57	6.9	12.5	Φ6.8	M8X1.25	10	16	23	22	60	11.2	7	9
LSH30F2(F3)N	42	6.5	90	31	95.5	103.5	100.5	70.5	52	72	8	13	Φ9	M10X1.5	10	18	28	26	80	14.2	9	12
LSH30F2(F3)L	42	6.5	90	31	118	126	123	93	52	72	8	13	Φ9	M10X1.5	10	18	28	26	80	14.2	9	12
LSH35F2(F3)N	48	7	100	33	109	118	114	80	62	82	9.2	12.5	Φ9	M10X1.5	13	21	34	29	80	14.2	9	12
LSH35F2(F3)L	48	7	100	33	134.5	143.5	139.5	105.5	62	82	9.2	12.5	Φ9	M10X1.5	13	21	34	29	80	14.2	9	12
LSH45F2(F3)N	60	10	120	37.5	132	141	137	98	80	100	10	16	Φ11	M12X1.75	15	22	45	38	105	20	14	17
LSH45F2(F3)L	60	10	120	37.5	164	173	169	130	80	100	10	16	Φ11	M12X1.75	15	22	45	38	105	20	14	17

Model/Item	Mounting Screw	Dynamic Load Rating(kN)	Static Load Rating(kN)	Static Rated Moment (kN.m)			Weight	
				C	C ₀	M _z	M _p	M _v
LSH15F2(F3)N	M4	11.3	17.9	0.12	0.12	0.12	0.2	1.43
LSH20F2(F3)N	M5	18.6	28.6	0.27	0.25	0.25	0.40	2.23
LSH20F2(F3)L	M5	22.2	37.6	0.35	0.34	0.34	0.8	2.23
LSH25F2(F3)N	M6	26.9	39.4	0.44	0.38	0.38	0.59	3.32
LSH25F2(F3)L	M6	32.9	53.0	0.58	0.57	0.57	0.85	3.32
LSH30F2(F3)N	M8	37.4	55.0	0.66	0.67	0.67	1.09	4.5
LSH30F2(F3)L	M8	45.7	73.1	0.88	0.91	0.91	1.38	4.5
LSH35F2(F3)N	M8	50.8	72.3	1.05	0.92	0.92	1.32	6.37
LSH35F2(F3)L	M8	61.9	96.1	1.52	1.45	1.45	1.8	6.37
LSH45F2(F3)N	M12	80.7	110.3	1.95	1.62	1.62	2.77	10.7
LSH45F2(F3)L	M12	98.5	146.9	2.59	2.92	2.92	3.67	10.7

Dimension of bottom-mount type rail

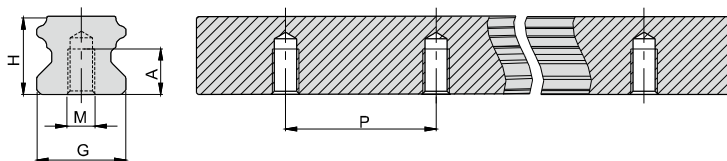

Model/Item	G	H	M	A	P
LSH15T	15	15	M5X0.8	8	60
LSH20T	20	17.5	M6X1.0	10	60
LSH25T	23	22	M6X1.0	12	60
LSH30T	28	26	M8X1.25	15	80
LSH35T	34	29	M8X1.25	17	80
LSH45T	45	38	M12X1.75	24	105

LSH Series

Accuracy

LSH standard type linear guide comes with 3 accuracy levels.

<p>The identification line of the Datum</p>	Accuracy Standards (mm)									
	Accuracy	N: Normal			H: High			P: Precision		
	Model	15/20	25/30/35	45	15/20	25/30/35	45	15/20	25/30/35	45
Tolerance of height H	±0.1			±0.03	±0.04	±0.05	±0.015	±0.02	±0.025	
Variation of height ΔH	0.02	0.025	0.03	0.01	0.015		0.006	0.007		
Tolerance of width Y	±0.1			±0.03	±0.04	±0.05	±0.015	±0.02	±0.025	
Variation of width ΔY	0.02	0.03		0.01	0.015	0.02	0.006	0.007	0.01	
Parallelism of C-surface relative to A-surface	Parallelism of raceway (Refer to Table 1)									
Parallelism of D-surface relative to B-surface	Parallelism of raceway (Refer to Table 1)									

Table 1 : Parallelism of the raceway

Rail Length(mm) Accuracy	100 under	100~200	200~300	300~500	500~700	700~900	900~1100	1100~1500	1500~1900	1900~2500	2500~3100	3100~3600	3600~4000	
	Parallelism of the raceway(μm)	N	12	14	15	17	20	22	24	26	28	31	33	36
	H	7	9	10	12	13	15	16	18	20	22	25	27	28
	P	3	4	5	6	7	8	9	11	13	15	18	20	21

Preload Level

1. Preload interference

The LSH standard type Linear Guide has three preload categories: A, B and C.

Choosing suitable preload level will enhance rigidity, precision and torsion resistant performance of the linear guide.

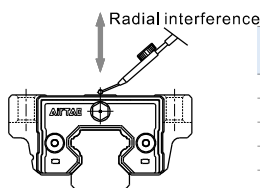

Model	Radial interference(μm)			
	Standard clearance(A)	Light Preload(B)	Medium Preload(C)	Heavy Preload(D)
LSH15	-4~+2	-12~-4	-22~-14	-
LSH20	-5~+2	-13~-5	-23~-15	-
LSH25	-6~+2	-14~-6	-24~-16	-33~-25
LSH30	-7~+2	-16~-7	-29~-20	-38~-29
LSH35	-8~+2	-21~-11	-34~-24	-43~-33
LSH45	-9~+2	-25~-16	-38~-27	-47~-36

2. Common Application

Refer to following table for suitable application of different preload grade:

Preload grade	Requirement	Common Application
Standard clearance(A)	One axial movement, small vibration and impact, accuracy requirement is low	Conveyor Machine, Semiconductor Equipment, Stage Equipment, Press Machine, Welding Machine and other light movement equipments
Light Preload(B)	Equipment that requires light-load and high-precision.	Z-axis movement for industrial use, NC lathe, EDM, Precision XY platform, Vertical machine center, measurement instrument, material feeder or industrial robot
Medium Preload(C)	Equipment that requires high rigidity, large vibration and shock.	Machining centers, NC lathes, grinders, vertical or horizontal milling machines, boring machines, tool guides, heavy cutting machines.
Heavy Preload(D)	Equipment that requires higher rigidity, larger vibration and shock.	Machining centers, NC lathes, grinders, vertical or horizontal milling machines, boring machines, tool guides, heavy cutting machines.

LSH Series

Installation Illustration

1. Allowable tolerance of mounting surface

LSH series is an arc-shape, two-point contact design of linear guide. Its self-centering feature allows some tolerance on mounting surface without affecting the smoothness of linear motion. The allowable tolerance is indicated in following table:

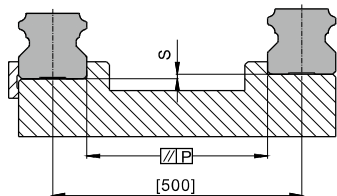

Model	Allowable tolerance of parallelism P(μm)			Allowable tolerance of top and bottom S (μm)		
	Standard clearance(A)	Light Preload(B)	Medium Preload(C)	Standard clearance(A)	Light Preload(B)	Medium Preload(C)
LSH15	25	18	13	130	85	35
LSH20	25	20	18	130	85	50
LSH25	30	22	20	130	85	70
LSH30	40	30	27	170	110	90
LSH35	50	35	30	210	150	120
LSH45	60	40	35	250	170	140

Note: The value in the table is the allowable value when the distance between the two linear guides is 500mm, and the allowable value is proportional to the distance between the two linear guides.

2. Height and Chamfer of Reference Edge

In order to ensure accurate installation of LSH Linear Guide, the contact space should not exceed the given figures in following table.

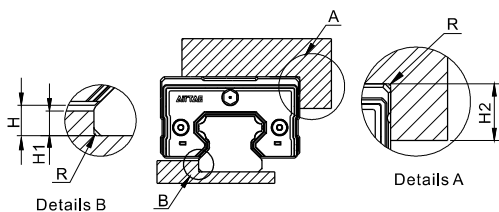

Unit : mm

Model	H	H1	H2	R(Max)
LSH15	3.5	3	4	0.5
LSH20	4.3	3.5	5	0.5
LSH25	6.5	5	5	1
LSH30	6.5	5	5	1
LSH35	7	6	6	1
LSH45	10	8	8	1

3. Screw Tighten Torque

When installing linear guide, whether the screws are well tighten and surface is well contacted will affect accuracy significantly. Please refer to following table for tightening force to ensure a perfect installation.

Model	Screw size	Tighten Torque(N.cm)		
		Iron	Casting	Aluminum alloy
LSH15	M4	412	274	206
LSH20	M5	882	588	441
LSH25	M6	1370	921	686
LSH30	M8	3040	2010	1470
LSH35	M8	3040	2010	1470
LSH45	M12	11800	7840	5880

4. Installation and Application

Linear guide installation methods can be divided into the followings.

For installations other than forward installation, the lubricant may fail.

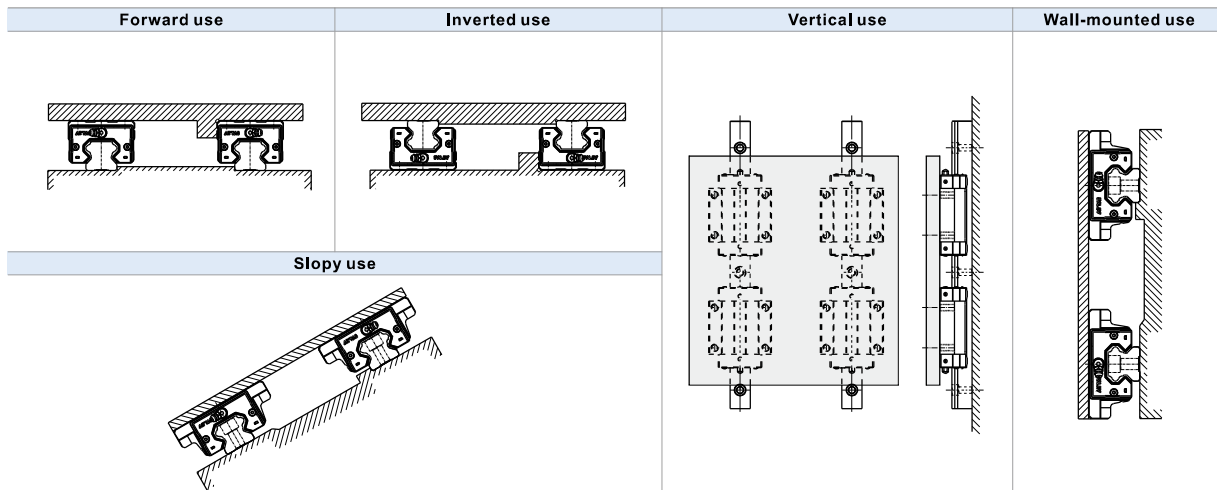

LSH Series

5. Datum plane

- Datum plane for installation must be ground or finely milled to ensure accuracy.
- Both sides of Rail can be used as the datum plane.
- For multi-blocks on a rail, identification line on blocks should be put on the same side to ensure moving accuracy.

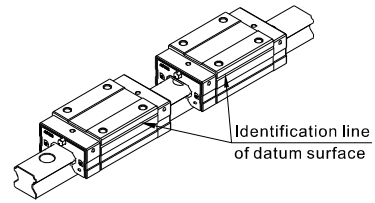

6. Fixation Method

Rails and blocks are possible to be displaced while the machine is subjected to vibrations and impacts thus to affect the accuracy. In order to avoid those difficulties and achieve high running accuracy, the following four methods are recommended for fixing.

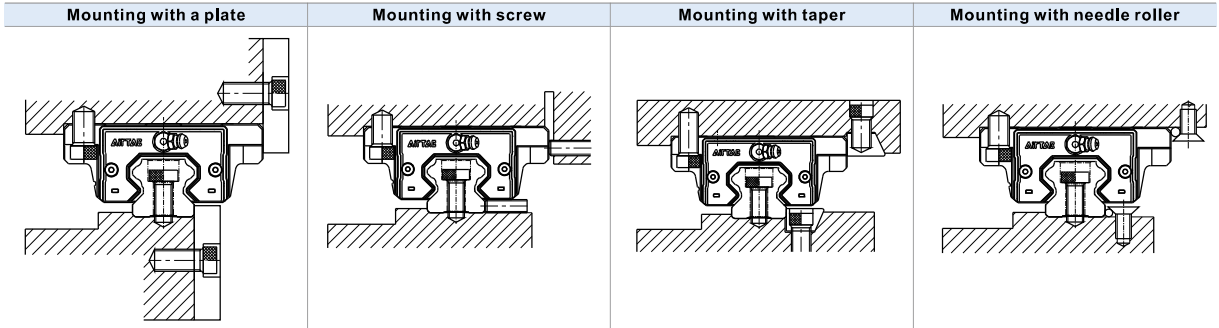

7. Rail Installation

A. Before installing the rail, remove all dirt from the mounting surface with oil stone, and then wipe with a clean cloth.

Remove all dirt from the mounting surface with oil stone, and then wipe with a clean cloth

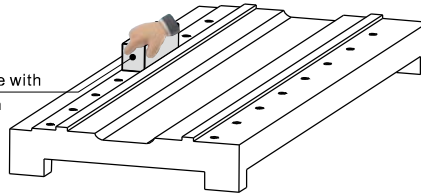

B. Place the rail gently on the bed firstly, then put the bolts into the mounting holes and pre-tighten them, place the rail ① into close contact with the datum plane of the bed by using the baffle, tighten the bolts with appropriate torque to fix the rail. Refer to "3. Screw tighten torque" for recommended torque value.

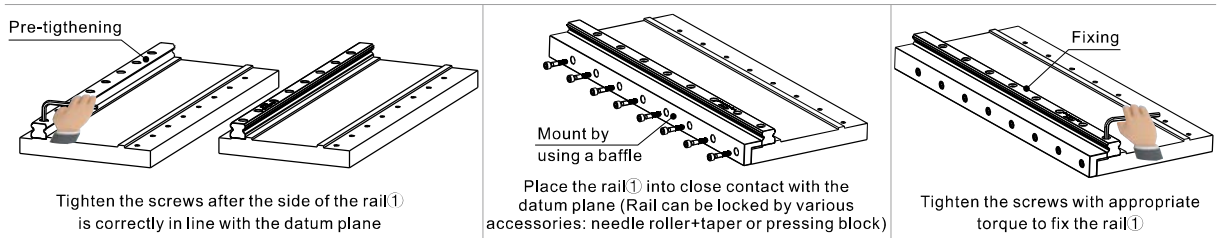

8. Block Installation

- Temporarily fix the table on the block by using the mounting bolts.
- Push the block datum plane against the side datum plane of the table and position the block by tightening the set screws.
- Tighten the mounting bolts in 1 to 4 sequences to fix the table on the block.

9. Subsidiary Rail Installation

Under the condition that the subsidiary rail has a reference datum plane, remove all dirt from the mounting surface with oil stone, and then wipe with a clean cloth, mount the subsidiary rail ② with the same method of the master rail ①.

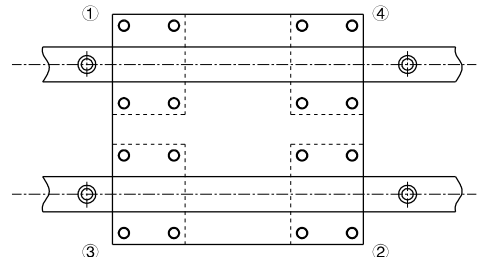
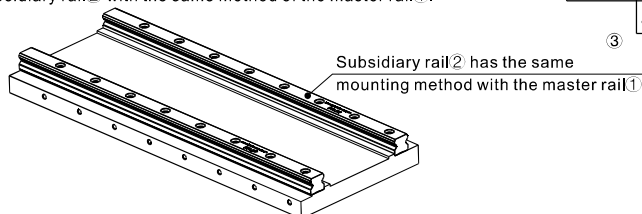

Under the condition that the subsidiary rail ② has a reference datum plane, remove all dirt from the mounting surface with oil stone, and then wipe with a clean cloth,

LSH Series

10. Rail Installation without Side Datum Surface

Using a provisional datum plane

Use the datum plane provided on the bed for straight alignment of the rail from one end to the other, attention must be paid to fix two blocks in close contact on the measuring plate.

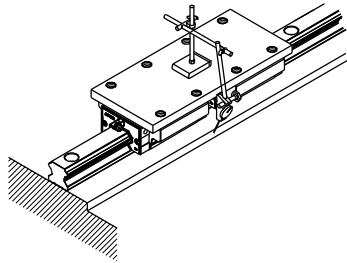

Using a straight-edge

Put the straight-edge between the two rails and use a dial gauge to adjust straight-edge in parallel with the side datum plane of the master rail. Use the dial gauge to ensure the straightness of the subsidiary rail by using the straight-edge as reference, then tighten the mounting bolts in proper sequence when the subsidiary rail is parallel to the master rail.

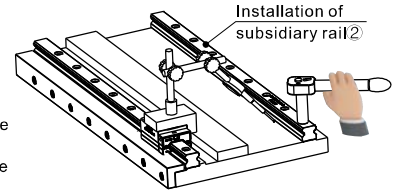

11. Rail Installation without Set Screws

To ensure parallelism between the subsidiary rail and the master rail in the condition without set screws, the following installation methods are recommended, and the installation of the block is the same as mentioned previously.

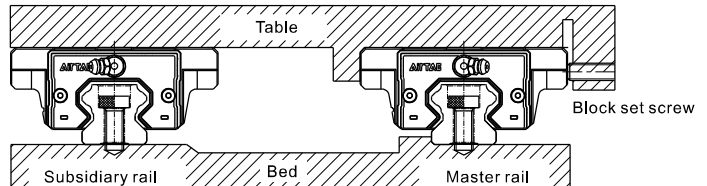

Installation of the master rail

Using a vice

Put the rail on the bed mounting surface and temporarily fasten the mounting bolts, then push the rail against the side datum plane of the bed by using a vice to ensure the rail position. Tighten the mounting bolts in proper sequence with specific torque.

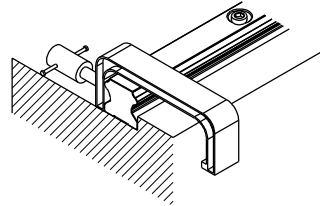

Installation of the subsidiary rail

Using a straight-edge

Put the straight-edge between the two rails and use a dial gauge to adjust straight-edge in parallel with the side datum plane of the master rail. Use the straight-edge to ensure the straightness of the subsidiary rail, then tighten the mounting bolts in proper sequence with specific torque.

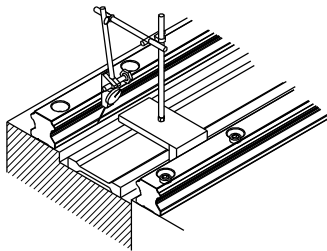

Using a table

Fix two blocks on the master rail to the table, and temporarily fix the subsidiary rail to the bed and one block on the subsidiary rail to the table. Place the gauge against the side surface of the block on the subsidiary rail, move the table from one end of the rail to the other end, then tighten the mounting bolts in proper sequence with specific torque while aligning the subsidiary rail parallel to the master rail.

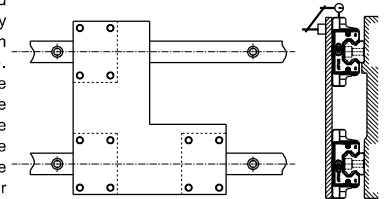

Following the master rail

Fix the table to the master rail and two blocks on the subsidiary rail, temporarily fix the other block on the subsidiary rail to the table and subsidiary rail to the bed. Moving the table from one end of the master rail and tighten the mounting bolts on the subsidiary rail in proper sequence with specific torque at the same time.

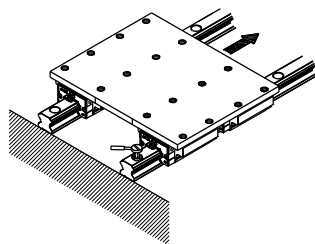

Using a jig

Use a special jig to help ensure the position of the subsidiary rail, and tighten the mounting bolts in proper sequence with specific torque.

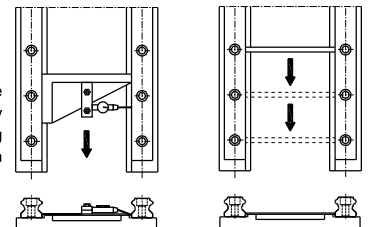

LSH Series

12. Rail Butt-jointed

- When it comes to butt-jointed rail installation, it must follow the butt-jointed marks shown below.
- In order to avoid the accuracy caused by installing the matched jointed rails, it is recommended to stagger the butt-jointed positions, see figure below.

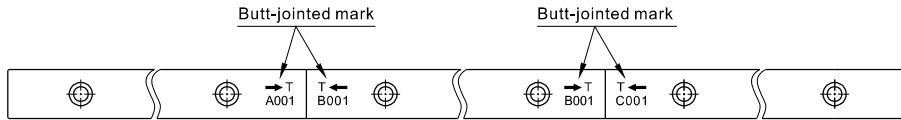

- When jointing rails, it must follow group marks on rail to ensure the accuracy of linear guide. These marks are located on the top surface at joint side. Please put the same group marks together.

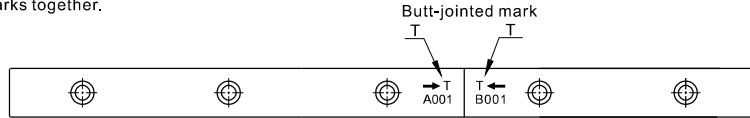

- Be aware serial number of group mark when assemble. A001 and B001 are in a group, so as to A002 and B002 and so on.
- Be aware the installation direction while assembly, the serial numbers are not upside down and arrows point to each other.

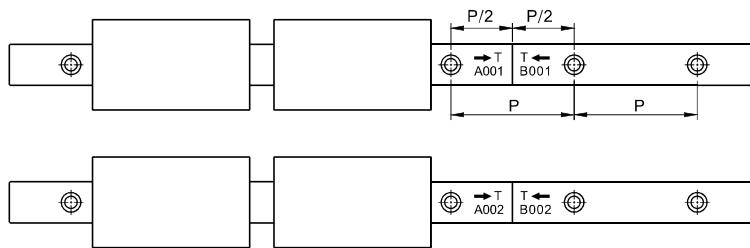

13. Measurement Method after Installation

When measuring running accuracy of the block, two blocks should be fixed on an inspection table in close contact to obtain stable accuracy.

When using a dial gauge, a provisional benchmark (like a straight-edge) is recommended to put as close as possible to the block for accurate measurement.

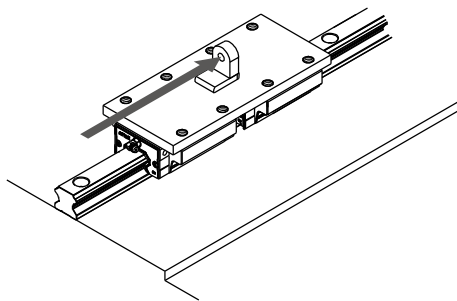

Method using an autocollimator

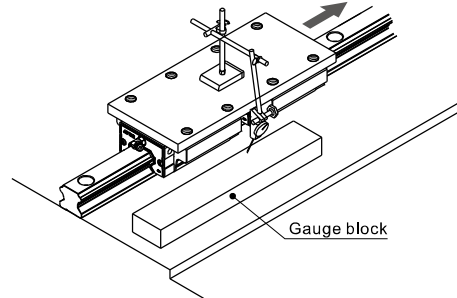

Method using a dial gauge

LSH Series

Lubrication method

When a linear guide is well lubricated, it can reduce wear and increase lifespan significantly. Lubrication has the following benefits :

- Reduces friction of the rollers and raceway to minimize wear.
- The grease film between contact surface can prevent roller fatigue.
- Prevent rust.

1. Lubrication Grease

Use the correct grade of lubrication. While lubricating, a grease gun can be used to pump grease into slider through the grease nipple on it.

The suitable condition for lube is when working speed is under 60 m/min and not in cooling process.

•Nipple type

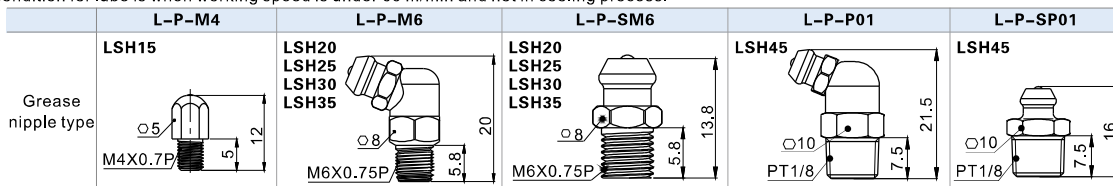

•Grease amount

LSH series linear guide is well lubricated with 'Shell Alvania grease S2' in factory. Customers are recommended to use identical or the same grade of lubricant. After lubrication, block needs to be moved back and forth at least three times for the length of three blocks and repeat at least twice. Check if the surface of rail is well covered by grease film.

Model	Grease amount for the first lubrication(cm ³)		Replenishment amount(cm ³)	
	Standard type	Long type	Standard type	Long type
LSH15	0.9	-	0.3	-
LSH20	1.8	2.7	0.6	0.9
LSH25	3.6	4.5	1.1	1.4
LSH30	5.4	7.2	1.7	2.2
LSH35	8.1	10	2.5	3
LSH45	8.4	10.4	2.8	3.5

•Lubrication frequency

Although the linear guides are well lubricated at the factory and retains grease well, frequent lubrication is still necessary to avoid undesirable wear.

Recommended lubrication period is every 100km of movement or every 3~6 months.

(Refer to table on the top for suggested amount)

2. Lubricating oil

Recommended oil viscosity for lubrication use is about 30 to 150 cst.

Lubrication oil is suitable for all kinds of load and impact application, but not for high temperature use due to its tendency of vaporization.

•Adaptor

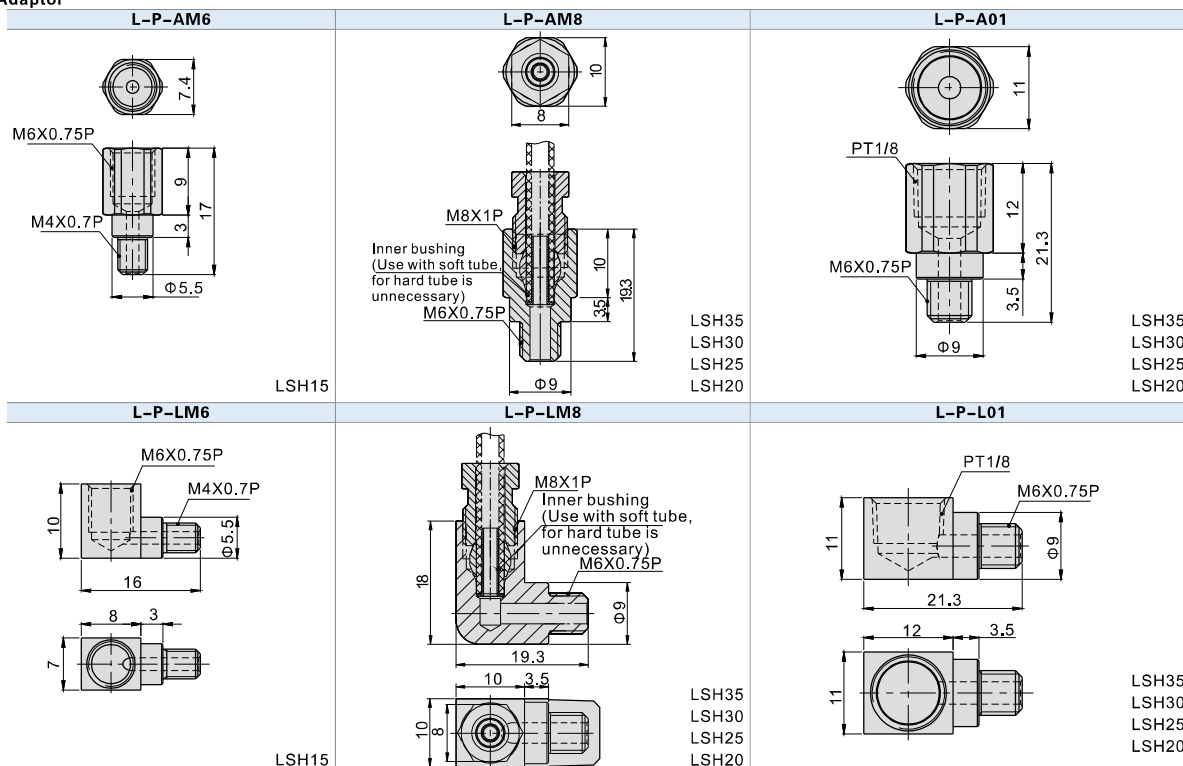

LSH Series

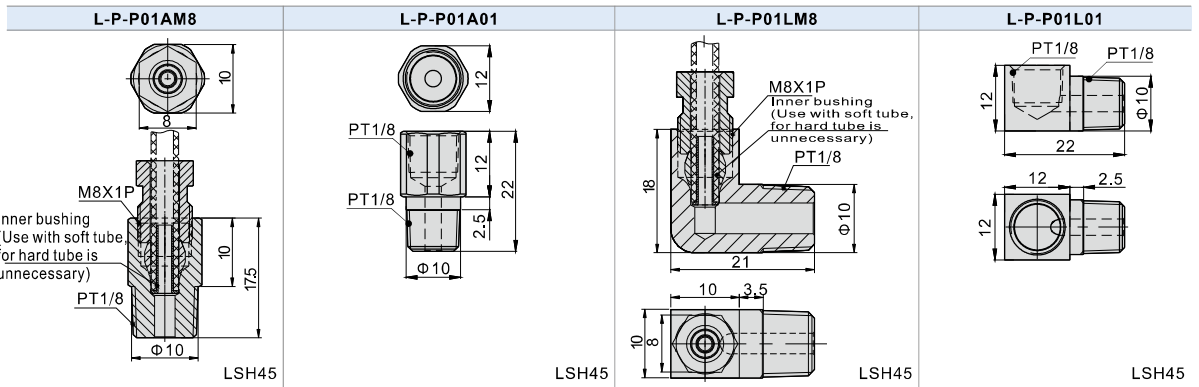

Note: After installation, the top surface of adaptor may be higher than block. Be careful about the interference while moving.

Lubrication method

Oil supply rate

Loss of lubrication oil is faster than lubrication grease. Pay attention to sufficiency of oil while using.

Model	Oil amount for the first lubrication(cm ³)	Feeding Speed(cm ³ /hr)
LSH15	0.6	0.2
LSH20	0.6	0.2
LSH25	0.9	0.3
LSH30	0.9	0.3
LSH35	0.9	0.3
LSH45	0.9	0.3

3. Grease nipple/adaptor installation

- Grease nipple or adaptor can be installed in the two sides of block for manual or automatic lubrication based on customer's requirement.
- There are a secondary set of lubricating ports on the side of the block. When using, it is not recommended to use the side with datum line unless necessary.
- Lateral nipple installation is not recommended for flange type blocks. (The grease / oil nipple may interfere with block)
- If lateral lubrication is needed for above spec, please contact us for customization.

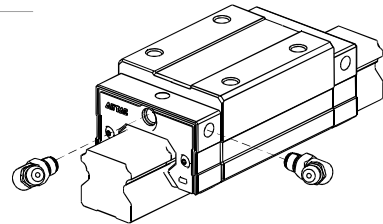

Bolt hole plug

1. Plug type

In order to prevent metal swarf or external objects from entering blocks and affecting precision and lifespan, customers must put plugs into holes during installation. Every rail is equipped with default plugs.

Model	Bolt	Diameter(D)(mm)	Thickness(H)(mm)
LSH15	M4	8.15	1.1
LSH20	M5	9.65	2.5
LSH25	M6	11.4	2.5
LSH30	M8	14.4	3.5
LSH35	M8	14.4	3.5
LSH45	M12	20.2	4.5

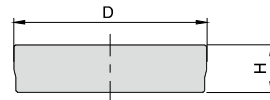

2. Plug installation Steps

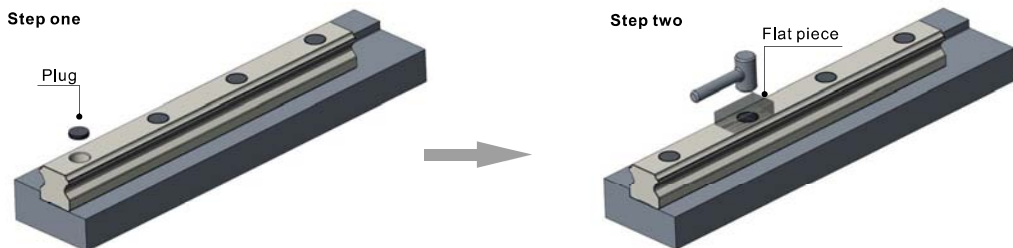

Place the plug in counterbore.

Note :

- Please make sure the plugs do not protrude the rail surface.
- After installation, please clean the surface before use.

Place the flat piece on mounting hole, hit the piece vertically with a plastic hammer and fix the plug into counterbore.

Dustproof standard type linear guide

LSH Series



Order Information(Combined)

LSH □ 15 H N 1 X220 S20 AH - AM6 - B - T - DD

① ② ③ ④ ⑤ ⑥ ⑦ ⑧ ⑨ ⑩ ⑪ ⑫ ⑬ ⑭

① Model Code	LSH:Dustproof standard type linear guide		
② Rail&Block surface treatment	Blank: without additional coating. (natural color) ★BB : Block and rail coated with black chrome		
③ Rail Width	15: 15mm 20: 20mm 25: 23mm 30: 28mm 35: 34mm 45: 45mm		
④ Block Style	H: Square type F1: Flange type, Mounting from top F2: Flange type, Mounting from bottom F3: Flange type, Mounting from top or bottom		
⑤ Block type	N: Standard L: Long [w/o 15 series]		
⑥ Number of Block	1: One 2: Two [Note: Amount of block on a single set of linear guide]		
⑦ Length of Rail	220:220mm[Defined by customer]		
⑧ Position of first mounting hole	S□ : Distance from end of rail to the center of first mounting hole (It is recommended to be greater than minimum margin)		
⑨ Preload	A: Standard clearance B: Light Preload C: Medium Preload D: Heavy Preload		
⑩ Accuracy	N : Normal H : High P : Precision		
⑪ Nipple /adapter type	M4: M4 Nipple		
	AM6: M4 to M6		
	LM6: M4 to M6		
	20: M6 to M6		
	25: M6 to M8		
	30: M6 to M8		
	35: M6 to M8		
		SM6: M6 Nipple	
			P01: PT1/8 Nipple
			A01: PT1/8 to PT1/8
			AM8: PT1/8 to M8
			L01: PT1/8 to PT1/8
			LM8: PT1/8 to M8
			SP01: PT1/8 Nipple
⑫ Packing type	Blank: the block and rail are assembled B: block and rail are put separately		
⑬ Rail type	Blank: Top-mount T: Bottom-mount		
⑭ Dust proof	DD: Double oil scrapers ZZ: Oil scraper + metal scraper		

[Note 1] For LSH-BB series, standard length of a rail is 3 m.
Please contact with our company if length of rail exceeds the maximum.
Add: Heavy preload is available for LSH25/30/35/45 only.

Dustproof standard type linear guide

LSH Series

Butt-jointed Order Information

LSH □ 15 H N 1X2970 T 2940 T 2970 A H-AM6-B-T-DD

① ② ③ ④ ⑤ ⑥ ⑦ ⑧ ⑨ ⑩ ⑪ ⑫ ⑬ ⑭ ⑮ ⑯ ⑰

Butt-jointed end margin: 1/2P ,
Position of the first and last
hole is defined by customer.

① Model Code	LSH:Dustproof standard type linear guide		
② Rail&Block surface treatment	Blank: without additional coating. (natural color) ★BB : Block and rail coated with black chrome		
③ Rail Width	15: 15mm 20: 20mm 25: 23mm 30: 28mm 35: 34mm 45: 45mm		
④ Block Style	H: Square type F1: Flange type, Mounting from top F2: Flange type, Mounting from bottom F3: Flange type, Mounting from top or bottom		
⑤ Block type	N: Standard L: Long [w/o 15 series]		
⑥ Number of Block	1: One 2: Two [Note: Amount of block on a single set of linear guide]		
⑦ Length of first Rail	2970:2970mm[Defined by customer]		
⑧ Butt-jointed mark	T: Rail Butt-jointed mark (Butt-jointed end margin:1/2P) [P is the standard hole distance]		
⑨ Length of second Rail	2940:2940mm[Defined by customer]		
⑩ Butt-jointed mark	Blank: two rails joint T: Rail Butt-jointed mark (Butt-jointed end margin:1/2P) [P is the standard hole distance]		
⑪ Length of third Rail	Blank: two rails joint 2970:2970mm.....[Defined by customer]		
⑫ Preload	A: Standard clearance B: Light Preload C: Medium Preload D: Heavy Preload		
⑬ Accuracy	N : Normal H : High		
⑭ Nipple /adapter type	M4: M4 Nipple	M6: M6 Nipple	P01: PT1/8 Nipple
	AM6: M4 to M6	A01: M6 to PT1/8	A01: PT1/8 to PT1/8
	LM6: M4 to M6	AM8: M6 to M8	AM8: PT1/8 to M8
		L01: M6 to PT1/8	L01: PT1/8 to PT1/8
		LM8: M6 to M8	LM8: PT1/8 to M8
		SM6: M6 Nipple	SP01: PT1/8 Nipple
⑮ Packing type	Blank: the block and rail are assembled B: block and rail are put separately		
⑯ Rail type	Blank: Top-mount T: Bottom-mount		
⑰ Dust proof	DD: Double oil scrapers ZZ: Oil scraper + metal scraper		

[Note1] For LSH-BB series, standard length of a rail is 3 m.

Maximum length of two-joint rail is 6 m. Maximum length of three-joint rail is 9 m.

Please contact with our company if length of rail exceeds the maximum.

Add1: Number of joints cannot be more than 2 times(three rails at most).

For LSH15/20/25, maximum length of jointed rail is 11800mm.

For LSH30/35, it's 11880. For LSH45, it's 11805.

Customization is needed for joint times more than standard.

Add2: Heavy preload is available for LSH25/30/35/45 only.

Dustproof standard type linear guide

LSH Series

1. Block Order Information

LSH □ 15 BK - H N - H - E - AM6 - DD

① ② ③ ④ ⑤ ⑥ ⑦ ⑧ ⑨ ⑩

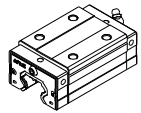

N: Standard

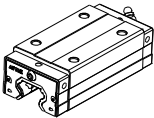

L: Long

① Model Code	LSH:Dustproof standard type linear guide				
② Coating on block	Blank: Block without additional coating. (natural color) ★B: Block coated with black chrome				
③ Rail Width	15: 15mm 20: 20mm 25: 23mm 30: 28mm 35: 34mm 45: 45mm				
④ Block Code	BK: Block				
⑤ Block Style	H: Square type F1: Flange type, Mounting from top F2: Flange type, Mounting from bottom F3: Flange type, Mounting from top or bottom				
⑥ Block type	N: Standard L: Long [w/o 15 series]				
⑦ Accuracy	N: Normal H: High				
⑧ Group code	SA SB SC SE SF B C E[Note1]				
⑨ Nipple /adapter type	15	M4: M4 Nipple	M6: M6 Nipple	P01: PT1/8 Nipple	
		AM6: M4 to M6 I type	A01: M6 to PT1/8 I type	A01: PT1/8 to PT1/8 I type	
	20 25 30 35	L type	AM8: M6 to M8	AM8: PT1/8 to M8	AM8: PT1/8 to M8
			L01: M6 to PT1/8 L type	L01: PT1/8 to PT1/8 L type	L01: PT1/8 to PT1/8 L type
	45		LM8: M6 to M8	LM8: PT1/8 to M8	LM8: PT1/8 to M8
			SM6: M6 Nipple	SP01: PT1/8 Nipple	SP01: PT1/8 Nipple
⑩ Dust proof	DD: Double oil scrapers ZZ: Oil scraper + metal scraper				

[Note1]: When selecting rails and bearings, the different pairing codes can change the units preload. details see "preload pairing chart".

LSH Series

Dust prevention illustration

1. Code and structure

AirTAC provides the following dust prevention accessories for the linear guides working in dusty environment, if the following accessories are demanded, please add the corresponding code when ordering.

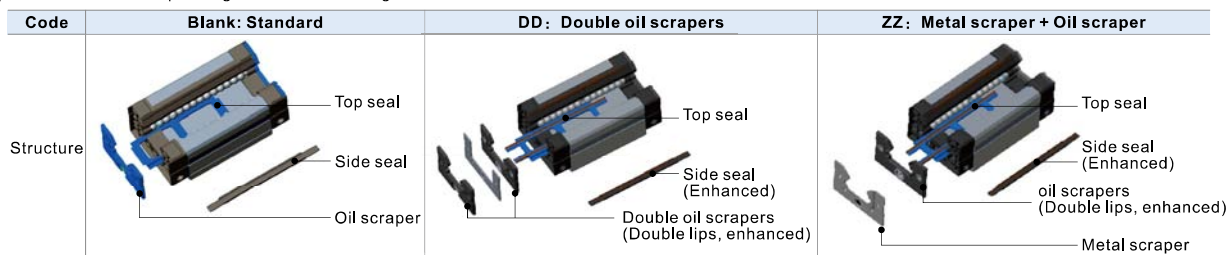

2. Test for high dust prevention

2.1. Test item

Test medium	Wood chip	Iron filing	Gravel
Running distance	500km	500km	500km

2.2. Test equipment

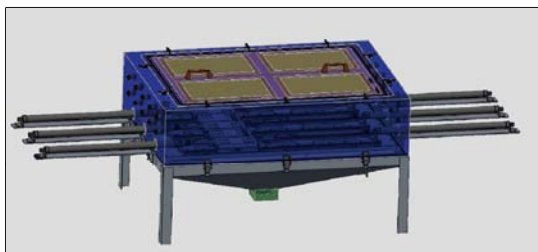

Figure1: Dust tester (Appearance)



Figure2: Dust tester (Inside)

2.3. Test condition

AirTAC adopts the industry's first dust tester (Figure 1) to simulate real working conditions, 360° without dead angles, all-round dust invasion (Figure 2). The dustproof test simulates multiple application scenarios, fully fill the air with wood chips, iron filings and gravels and are strictly tested to ensure the quality and dustproof effect of each block.

2.4. Test result

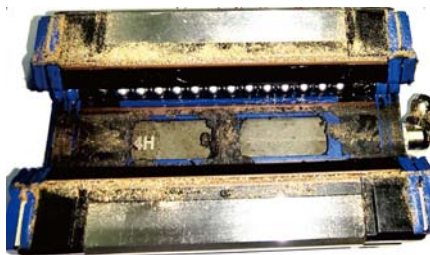

Figure3: Steel balls



Figure4: Steel balls

Result: It can be seen from the Figure 3 and 4 that little amount of dust enters the inside of the block after testing, and the steel ball surface is still smooth, the block still runs smoothly and the performance is not affected.

Note: The above test results are obtained from AirTAC lab.

3. Dimensions

Highly dustproof type blocks have different length compared with the standard blocks (only dimension C is different from the standard, the others keep same), see the table on the right for details.

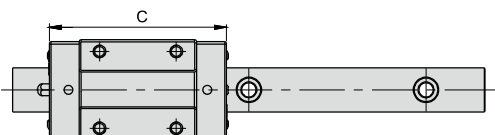

Model	Type	Length C(mm)		
		Standard (Blank)	Double oil scrapers(DD)	Oil scraper+Metal scraper(ZZ)
LSH15□N	Standard	60	67	64,5
LSH20□N	Standard	76.5	84.5	81
LSH20□L	Long	90.5	98.5	95
LSH25□N	Standard	83.5	91.5	88
LSH25□L	Long	105	113	109.5
LSH30□N	Standard	95.5	103.5	100.5
LSH30□L	Long	118	126	123
LSH35□N	Standard	109	118	114
LSH35□L	Long	134.5	143.5	139.5
LSH45□N	Standard	132	140.5	136.5
LSH45□L	Long	163.5	172	168

Self-lubricator Standard Linear Guide

LSH Series



Order Information(Combined)

LSH □ 15 H N 1 X220 S20 A H - AM6 - B - T - E

① ② ③ ④ ⑤ ⑥ ⑦ ⑧ ⑨ ⑩ ⑪ ⑫ ⑬ ⑭

① Model Code	LSH:Self-lubricator Standard Linear Guide		
② Rail&Block surface treatment	Blank: without additional coating. (natural color) ★BB : Block and rail coated with black chrome		
③ Rail Width	15: 15mm 20: 20mm 25: 23mm 30: 28mm 35: 34mm 45: 45mm		
④ Block Style	H: Square type F1: Flange type, Mounting from top F2: Flange type, Mounting from bottom F3: Flange type, Mounting from top or bottom		
⑤ Block type	N: Standard L: Long [w/o 15 series]		
⑥ Number of Block	1: One 2: Two [Note: Amount of block on a single set of linear guide]		
⑦ Length of Rail	220:220mm[Defined by customer]		
⑧ Position of first mounting hole	S□ : Distance from end of rail to the center of first mounting hole (It is recommended to be greater than minimum margin)		
⑨ Preload	A: Standard clearance B: Light Preload C: Medium Preload D: Heavy Preload		
⑩ Accuracy	N : Normal H : High P : Precision		
⑪ Nipple /adapter type	M4: M4 Nipple	M6: M6 Nipple	P01: PT1/8 Nipple
	AM6: M4 to M6	A01: M6 to PT1/8	A01: PT1/8 to PT1/8
		AM8: M6 to M8	AM8: PT1/8 to M8
	LM6: M4 to M6	L01: M6 to PT1/8	L01: PT1/8 to PT1/8
	LM8: M6 to M8	LM8: PT1/8 to M8	
	SM6: M6 Nipple	SP01: PT1/8 Nipple	
⑫ Packing type	Blank: the block and rail are assembled B: block and rail are put separately		
⑬ Rail type	Blank: Top-mount T: Bottom-mount		
⑭ Self-lubricator Standard Type	E: Self-lubricator Standard Type		

[Note1] For LSH-BB series, standard length of a rail is 3 m.

Please contact with our company if length of rail exceeds the maximum.

Add: Heavy preload is available for LSH25/30/35/45 only.

Self-lubricator Standard Linear Guide

LSH Series

Butt-jointed Order Information

LSH □ 15 H N 1X2970 T 2940 T 2970 A H-AM6-B - T - E

① ② ③ ④ ⑤ ⑥ ⑦ ⑧ ⑨ ⑩ ⑪ ⑫ ⑬ ⑭ ⑮ ⑯ ⑰

① Model Code	LSH:Self-lubricator Standard Linear Guide		
② Rail&Block surface treatment	Blank: without additional coating. (natural color) ★BB : Block and rail coated with black chrome		
③ Rail Width	15: 15mm	20: 20mm	25: 23mm 30: 28mm 35: 34mm 45: 45mm
④ Block Style	H: Square type F1: Flange type, Mounting from top F2: Flange type, Mounting from bottom F3: Flange type, Mounting from top or bottom		
⑤ Block type	N: Standard L: Long [w/o 15 series]		
⑥ Number of Block	1: One 2: Two [Note: Amount of block on a single set of linear guide]		
⑦ Length of first Rail	2970:2970mm[Defined by customer]		
⑧ Butt-jointed mark	T: Rail Butt-jointed mark (Butt-jointed end margin:1/2P) [P is the standard hole distance]		
⑨ Length of second Rail	2940:2940mm[Defined by customer]		
⑩ Butt-jointed mark	Blank: two rails joint T: Rail Butt-jointed mark (Butt-jointed end margin:1/2P) [P is the standard hole distance]		
⑪ Length of third Rail	Blank: two rails joint 2970:2970mm.....[Defined by customer]		
⑫ Preload	A: Standard clearance B: Light Preload C: Medium Preload D: Heavy Preload		
⑬ Accuracy	N : Normal H : High		
⑭ Nipple /adapter type	M4: M4 Nipple	M6: M6 Nipple	P01: PT1/8 Nipple
	AM6: M4 to M6	A01: M6 to PT1/8	A01: PT1/8 to PT1/8
	LM6: M4 to M6	L01: M6 to PT1/8	L01: PT1/8 to PT1/8
		SM6: M6 Nipple	SP01: PT1/8 Nipple
⑮ Packing type	Blank: the block and rail are assembled B: block and rail are put separately		
⑯ Rail type	Blank: Top-mount T: Bottom-mount		
⑰ Self-lubricator Standard Type	E: Self-lubricator Standard Type		

Butt-jointed end margin:1/2P ,
Position of the first and last hole is defined by customer.

- [Note1] For LSH-BB series, standard length of a rail is 3 m.
Maximum length of two-joint rail is 6 m. Maximum length of three-joint rail is 9 m.
Please contact with our company if length of rail exceeds the maximum.
- Add1: Number of joints cannot be more than 2 times(three rails at most).
For LSH15/20/25, maximum length of jointed rail is 11800mm.
For LSH30/35, it's 11880. For LSH45, it's 11805.
Customization is needed for joint times more than standard.
- Add2: Heavy preload is available for LSH25/30/35/45 only.

LSH Series

1. Block Order Information

LSH □ 15 BK-H N-H-E-AM6-E

① ② ③ ④ ⑤ ⑥ ⑦ ⑧ ⑨ ⑩

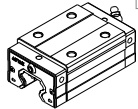

N: Standard

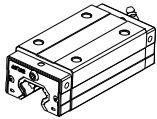

L: Long

① Model Code	LSH:Self-lubricator Standard Linear Guide					
② Coating on block	Blank: Block without additional coating. (natural color) ★B: Block coated with black chrome					
③ Rail Width	15: 15mm 20: 20mm 25: 23mm 30: 28mm 35: 34mm 45: 45mm					
④ Block Code	BK: Block					
⑤ Block Style	H: Square type F1: Flange type, Mounting from top F2: Flange type, Mounting from bottom F3: Flange type, Mounting from top or bottom					
⑥ Block type	N: Standard L: Long [w/o 15 series]					
⑦ Accuracy	N: Normal H: High					
⑧ Group code	SA SB SC SE SF B C E [Note1]					
⑨ Nipple /adapter type	15	M4: M4 Nipple		45	P01:PT1/8 Nipple	
		AM6: M4 to M6 I type			A01:PT1/8 to PT1/8 I type	
		AM6: M4 to M6			AM8:PT1/8 to M8	
		L type			L01:PT1/8 to PT1/8 L type	
		LM6: M4 to M6			LM8:PT1/8 to M8	
		SM6:M6 Nipple			SP01:PT1/8 Nipple	
⑩ Self-lubricator Standard Type	E: Self-lubricator Standard Type					

[Note1]: When selecting rails and bearings, the different pairing codes can change the units preload. details see "preload pairing chart".

LSH Series

Self-lubricator illustration

1.Code and structure

AirTAC provides self-lubricator for applications e.g. limited spaces, or where grease maintenance is challenging.

If needed, please add the code "E" after the product model.

E.g. LSH15HN1X220S20AH-AM6 - B - T - E

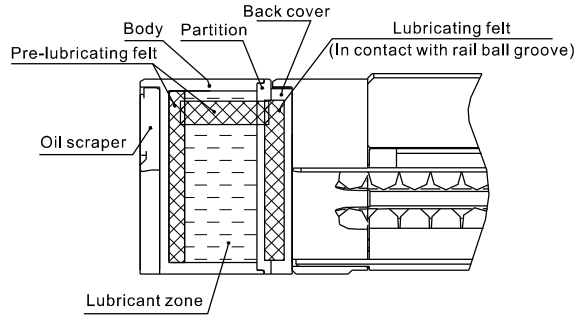
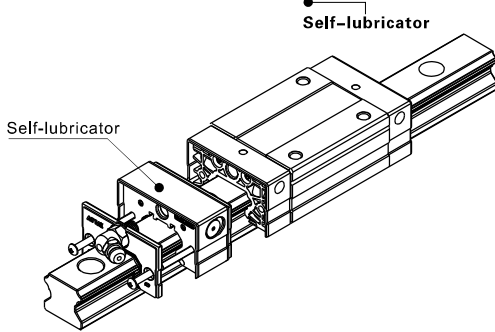

Product Features

1. Easy Maintenance and Long-Term Maintenance-Free Operation: In normal applications, basically no additional grease maintenance is required throughout lifespan of linear guide.
 2. Cost Savings: No additional lubrication is needed for the block, reducing labor and material costs.
 3. Flexible Use in Specific Environments: Equipped with a high-capacity grease tank, allowing the use of specific lubricants for specific environments.
 4. Dustproof Design: Built-in dustproof structure extends lifespan.
 5. Flexible in usage and installation: the assembling and disassembling of self-lubricator in integrity structure is convenient, can have it according to different working condition.
- [Note] Self-lubricator type block is not applicable for ultra-smooth application, as the higher viscosity of the lubricant in self-lubricator will increase friction by approximately 5-7N.

Durability test of self-lubricator

Test specification	Test specification	Model	Speed	Stroke	Lubricant type
Lubricating effect		LSH20	30m/min	1200mm	ISO VG680 high-quality extreme pressure lubricant

Test result

Test result shows that after running 1,000 km, only 20% of the grease is consumed, and the linear guide remains lubricated. The expected service life can possibly exceed 4,000 km.

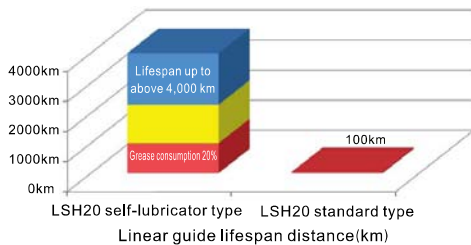

When comparing each sub-series with the self-lubricator and the standard model, the length of block will change. Please refer to the table below for details.

- Block dimension comparison (only dimension C is different from the standard, the rest remains the same)

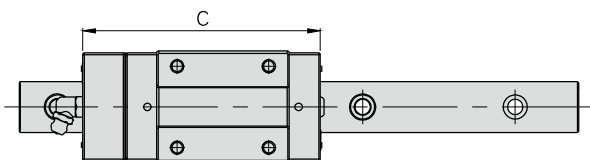

Model	Type	Length C(mm)	
		Standard (Blank)	Self-lubricator Standard Type
LSH15□N	Standard	60	75.5
LSH20□N	Standard	76.5	93.5
LSH20□L	Long	90.5	107.5
LSH25□N	Standard	83.5	100.5
LSH25□L	Long	105	122
LSH30□N	Standard	95.5	112.5
LSH30□L	Long	118	135
LSH35□N	Standard	109	126
LSH35□L	Long	134.5	151.5
LSH45□N	Standard	132	152.5
LSH45□L	Long	164	184.5

LSH Series

Precautions on use

1. Block disassembly

With ball retainers and a dustproof cover, normally the balls are prevented from falling out when block is removed from rail. However, if obliquely insert rail into blocks or quickly assembled or disassembled, there is a risk for balls of falling out. Please carefully assemble the linear guide or use plastic rails to assist.

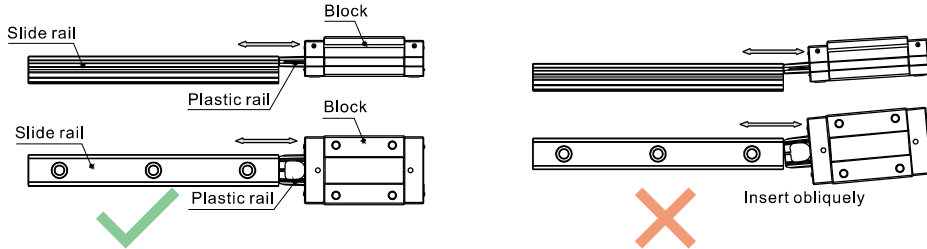

2. Plastic rail installation

A plastic rail is equipped for individual block set. Please do not remove plastic rail whenever it is not necessary. If plastic rail falls out and needs to be reinstalled, press the dustproof covers with fingers and install slowly to prevent balls from falling out due to misalignment of plastic rail.

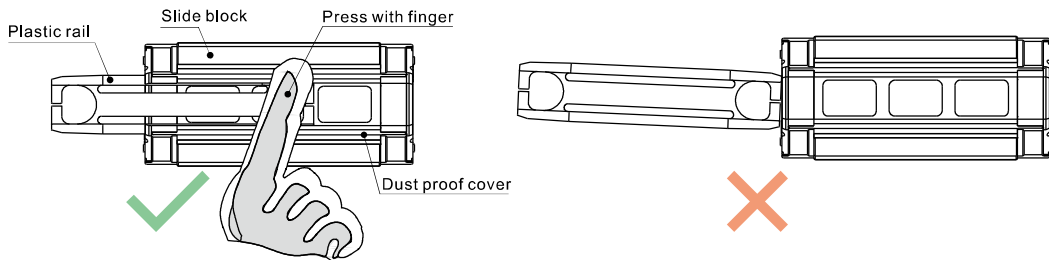

Press the dust-proof covers and insert plastic rail in alignment.

Without pressing dust-proof covers or insert plastic rail obliquely.

3. Caution

- Parts may slide out if linear guide is put unevenly. Please be careful.
- Hitting or dropping linear guide could have huge effect on accuracy and lifespan even though appearance may remain intact. Please be careful.
- Do not disassemble linear guide as external objects may enter blocks and cause accuracy problem.

4. Lubrication

- Linear guide have been treated with anti-rust oil during production. Before use, wipe the rail and treat it with lubrication.
- Do not mix lubricating oil (grease) with different properties.
- After lubrication, move block back and forth for the length of three blocks long and repeat at least 2 times to ensure there is a grease file on rail.

5. Use

- The operating environment temperature should not exceed 80°C, and the maximum temperature should not exceed 100°C.
- Do not separate blocks from rail whenever it is not necessary. If you need to separate them, please use plastic rails to prevent steel balls from falling out.

6. Storage

- When storing blocks, rails or linear guide set, please be sure that anti-rust oil is well applied and product is well sealed as well as placed horizontally. Avoid humidity and high temperatures environment.



LSD Series Low Profile Type Linear Guide

Product Introduction

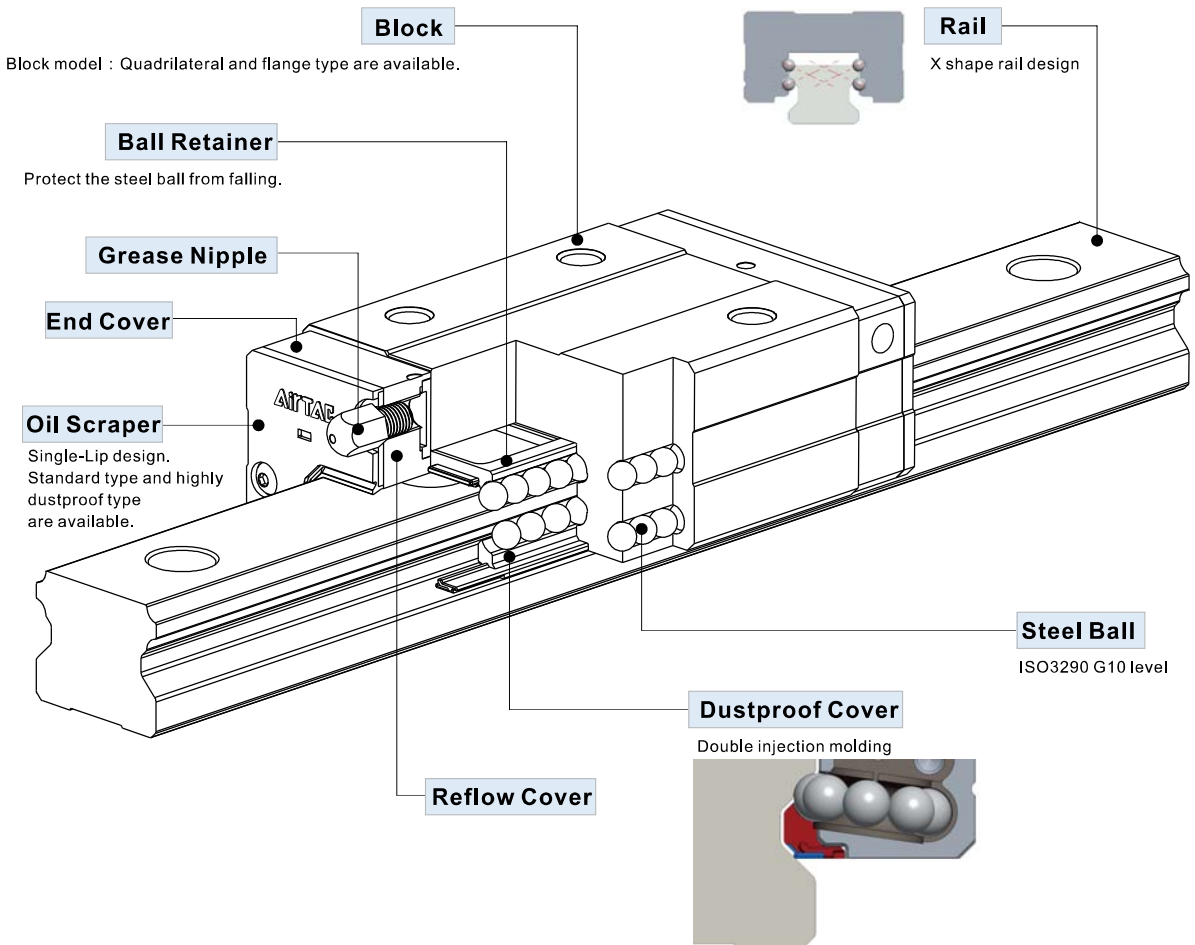

Product Features

1. With self-adjustment ability

X-shaped (45° - 45°) of curved groove on cross section design makes it self-aligning. Even small misalignment exists on the mounting surface, this design can help absorb it and maintain high precision, smooth and stable linear motion.

2. Low profile, High rigidity, equal load on four direction design

The 45-degree contact angle design of the four rows of steel balls and the raceway allow the steel balls to achieve the ideal two-point contact, and can withstand the action and reaction force from the radial and lateral direction. Meanwhile, pre-load can be applied to increase extra rigidity if necessary. Reduce the combined height of the slide block and the slide rail, shorten the length of the slide block, to achieve miniaturization.

3. Interchangeable

Because of the strict control on manufacturing process, the dimensional accuracy is stable and within the set tolerance.

Besides, the ball retainer design can prevent steel balls from falling out. Therefore when assembling, blocks are interchangeable within the same spec and still maintain consistency of pre-load and accuracy.



Low Profile Type Linear Guide

LSD Series



Order Information(Combined)

1、LSD15/30

LSD □ 15 H N 1 X 220 S20 A H - U - AM6 - B - T

① ② ③ ④ ⑤ ⑥ ⑦ ⑧ ⑨ ⑩ ⑪ ⑫ ⑬ ⑭

① Model Code	LSD:Low Profile Type Linear Guide			
② Rail&Block surface treatment	Blank: without additional coating. (natural color) ★BB : Block and rail coated with black chrome			
③ Rail Width	15:15mm 30:28mm			
④ Block Style	H: Square type F1: Flange type, Mounting from top F2: Flange type, Mounting from bottom F3: Flange type, Mounting from top or bottom			
⑤ Block type	S: Short N: Standard			
⑥ Number of Block	1: One 2: Two [Note: Amount of block on a single set of linear guide]			
⑦ Length of Rail	220:220mm[Defined by customer]			
⑧ Position of first mounting hole	S□ : Distance from end of rail to the center of first mounting hole (It is recommended to be greater than minimum margin)			
⑨ Preload	A: Standard clearance B: Light Preload C: Medium Preload			
⑩ Accuracy	N : Normal H : High P : Precision			
⑪ Rail type	LSD15:Blank: Top-mount(M4)		LSD15:U: Top-mount(M3)	
	LSD30:Blank: Top-mount(M6)		LSD30:U: Top-mount(M8)	
⑫ Nipple /adapter type	LSD15: M4: M4 Nipple	LSD15: AM6: M4 to M6	LSD15: LM6: M4 to M6	LSD30: SM6: M6 Nipple
	LSD30: M6: M6 Nipple	LSD30: A01: M6 to PT1/8	LSD30: L01: M6 to PT1/8	
⑬ Packing type	M4	M6	I type	L type
	Blank: the block and rail are assembled B: block and rail are put separately			
⑭ Rail type	Blank: Top-mount T: Bottom-mount			

★[Note 1] Dustproof standard type please refer to Pg. 52. for more detail.

★[Note 2] Self-lubricator standard type please refer to Pg. 58. for more detail.

[Note 3] For LSD-BB series, standard length of a rail is 3 m.

Please contact with our company if length of rail exceeds the maximum.





Add: Rail type indicated in ⑩ and ⑭ in ordering code cannot be selected at the same time, only one of them can be selected.

LSD Series

2. LSD20/25/35

LSD □ 20 H N 1 X220 S20 A H - AM8 - B - T

① ② ③ ④ ⑤ ⑥ ⑦ ⑧ ⑨ ⑩ ⑪ ⑫ ⑬

① Model Code	LSD:Low Profile Type Linear Guide			
② Rail&Block surface treatment	Blank: without additional coating. (natural color) ★BB : Block and rail coated with black chrome			
③ Rail Width	20:20mm 25:23mm 35:34mm			
④ Block Style	H: Square type F1: Flange type, Mounting from top F2: Flange type, Mounting from bottom F3: Flange type, Mounting from top or bottom			
⑤ Block type	S: Short N: Standard			
⑥ Number of Block	1: One 2: Two [Note: Amount of block on a single set of linear guide]			
⑦ Length of Rail	220:220mm[Defined by customer]			
⑧ Position of first mounting hole	S□ : Distance from end of rail to the center of first mounting hole (It is recommended to be greater than minimum margin)			
⑨ Preload	A: Standard clearance B: Light Preload C: Medium Preload			
⑩ Accuracy	N : Normal H : High P : Precision			
⑪ Nipple /adapter type	M6:M6 Nipple	A01:M6 to PT1/8 AM8:M6 to M8	L01:M6 to PT1/8 LM8:M6 to M8	SM6: M6 Nipple
		I type 	L type 	SM6 
⑫ Packing type	Blank: the block and rail are assembled B: block and rail are put separately			
⑬ Rail type	Blank: Top-mount T: Bottom-mount			

★[Note 1] Dustproof standard type please refer to Pg. 52. for more detail.

★[Note 2] Self-lubricator standard type please refer to Pg. 58. for more detail.

[Note 3] For LSD-BB series, standard length of a rail is 3 m.

Please contact with our company if length of rail exceeds the maximum.

Low Profile Type Linear Guide

LSD Series

Butt-jointed Order Information

1、LSD15/30

LSD □ 15 H N 1X2970 T 2940T2970 A H-U- AM6-B -T

① ② ③ ④ ⑤ ⑥ ⑦ ⑧ ⑨ ⑩ ⑪ ⑫ ⑬ ⑭ ⑮ ⑯ ⑰

Butt-jointed end margin:1/2P ,
Position of the first and last
hole is defined by customer.

① Model Code	LSD:Low Profile Type Linear Guide			
② Rail&Block surface treatment	Blank: without additional coating. (natural color) ★BB : Block and rail coated with black chrome			
③ Rail Width	15:15mm	30:28mm		
④ Block Style	H: Square type F1: Flange type, Mounting from top F2: Flange type, Mounting from bottom F3: Flange type, Mounting from top or bottom			
⑤ Block type	S: Short N: Standard			
⑥ Number of Block	1: One 2: Two [Note: Amount of block on a single set of linear guide]			
⑦ Length of first Rail	2970:2970mm[Defined by customer]			
⑧ Butt-jointed mark	T: Rail Butt-jointed mark(Butt-jointed end margin:1/2P) [P is the standard hole distance]			
⑨ Length of second Rail	2940:2940mm[Defined by customer]			
⑩ Butt-jointed mark	Blank: two rails joint T: Rail Butt-jointed mark (Butt-jointed end margin:1/2P) [P is the standard hole distance]			
⑪ Length of third Rail	Blank: two rails joint 2970:2970mm.....[Defined by the customer]			
⑫ Preload	A: Standard clearance B: Light Preload C: Medium Preload			
⑬ Accuracy	N : Normal H : High			
⑭ Rail type	LSD15:Blank: Top-mount(M4)	LSD15:U: Top-mount(M3)		
	LSD30:Blank: Top-mount(M6)	LSD30:U: Top-mount(M8)		
	LSD15	LSD30	LSD15	LSD30
⑮ Nipple /adapter type	LSD15: M4: M4 Nipple	LSD15: AM6: M4 to M6	LSD15: LM6: M4 to M6	LSD30: SM6: M6 Nipple
	LSD30: M6: M6 Nipple	LSD30: A01: M6 to PT1/8	LSD30: L01: M6 to PT1/8	
⑯ Packing type	M4	M6	I type	L type
⑰ Rail type	Blank: the block and rail are assembled B: block and rail are put separately			
	Blank: Top-mount T: Bottom-mount			

★[Note 1] Dustproof standard type please refer to Pg. 52. for more detail.

★[Note 2] Self-lubricator standard type please refer to Pg. 58. for more detail.

[Note 3] For LSD-BB series, standard length of a rail is 3 m.

Maximum length of two-joint rail is 6 m.

Maximum length of three-joint rail is 9 m.

Please contact with our company

if length of rail exceeds the maximum.

Add1 : Number of joints cannot be more than 2 times(three rails at most).

For LSD15, maximum length of jointed rail is 11800mm.

For LSD30, it's 11880.

Customization is needed for joint times more than standard.

Add2 : Rail type indicated in ⑭ and ⑮ in ordering code cannot be selected at the same time, only one of them can be selected.





LSD Series

2、LSD20/25/35

LSD □ 20 H N 1X2970T2940T2970A H-AM8-B -T

① ② ③ ④ ⑤ ⑥ ⑦ ⑧ ⑨ ⑩ ⑪ ⑫ ⑬ ⑭ ⑮ ⑯

Butt-jointed end margin: 1/2P
Position of the first and last hole is defined by customer.

① Model Code	LSD:Low Profile Type Linear Guide			
② Rail&Block surface treatment	Blank: without additional coating. (natural color) ★BB : Block and rail coated with black chrome			
③ Rail Width	20:20mm	25:23mm	35:34mm	
④ Block Style	H: Square type F1: Flange type, Mounting from top F2: Flange type, Mounting from bottom F3: Flange type, Mounting from top or bottom			
⑤ Block type	S: Short N: Standard			
⑥ Number of Block	1: One 2: Two [Note: Amount of block on a single set of linear guide]			
⑦ Length of first Rail	2970:2970mm[Defined by customer]			
⑧ Butt-jointed mark	T: Rail Butt-jointed mark (Butt-jointed end margin:1/2P) [P is the standard hole distance]			
⑨ Length of second Rail	2940:2940mm[Defined by customer]			
⑩ Butt-jointed mark	Blank: two rails joint T: Rail Butt-jointed mark (Butt-jointed end margin:1/2P) [P is the standard hole distance]			
⑪ Length of third Rail	Blank: two rails joint 2970:2970mm..[Defined by the customer]			
⑫ Preload	A: Standard clearance B: Light Preload C: Medium Preload			
⑬ Accuracy	N : Normal H : High			
⑭ Nipple /adapter type	M6: M6 Nipple	A01: M6 to PT1/8 AM8: M6 to M8	L01: M6 to PT1/8 LM8: M6 to M8	SM6: M6 Nipple
		I type 	L type 	SM6 
⑮ Packing type	Blank: the block and rail are assembled B: block and rail are put separately			
⑯ Rail type	Blank: Top-mount T: Bottom-mount			

- ★[Note 1] Dustproof standard type please refer to Pg. 52. for more detail.
- ★[Note 2] Self-lubricator standard type please refer to Pg. 58. for more detail.
- [Note 3] For LSD-BB series, standard length of a rail is 3 m.
Maximum length of two-joint rail is 6 m.
Maximum length of three-joint rail is 9 m.
Please contact with our company if length of rail exceeds the maximum.
- Add: Number of joints cannot be more than 2 times(three rails at most).
For LSD20/25, maximum length of jointed rail is 11800mm.
For LSD35, it's 11880.
Customization is needed for joint times more than standard.

Low Profile Type Linear Guide

LSD Series

1. Block Order Information

LSD □ 15 BK - H N - H - E - AM6



- ★ [Note 1] Dustproof standard type please refer to Pg. 52. for more detail.
- ★ [Note 2] Self-lubricator standard type please refer to Pg. 58. for more detail.
- [Note3] When selecting rails and bearings, the different pairing codes can change the units preload, details see "preload pairing chart".

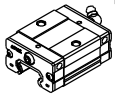

S: Short

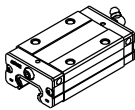

N: Standard

① Model Code	LSD:Low Profile Type Linear Guide				
② Coating on block	Blank: Block without additional coating. (natural color) ★B: Block coated with black chrome				
③ Rail Width	15:15mm	20:20mm	25:23mm	30:28mm 35:34mm	
④ Block Code	BK: Block				
⑤ Block Style	H: Square type F1: Flange type, Mounting from top F2: Flange type, Mounting from bottom F3: Flange type, Mounting from top or bottom				
⑥ Block type	S: Short N: Standard				
⑦ Accuracy	N: Normal H: High				
⑧ Group code	SA SB SC C E [Note3]				
⑨ Nipple /adapter type	M4	M4 Nipple		M6 M6 Nipple	
		AM6	M4 to M6		A01 M6 to PT1/8 AM8 M6 to M8
	15	LM6	M4 to M6	L type	L type
					20 25 30 35
					SM6 M6 Nipple

2. Rail(4m) Order Information

(1) LSD15/30

LSD 15 RL X 4000 - H - E - U



① Model Code	LSD:Low Profile Type Linear Guide			
② Rail Width	15:15mm 30:28mm			
③ Rail Code	RL: Rail			
④ Rail Length	4000 : 4000mm			
⑤ Accuracy	N : Normal H : High			
⑥ Group code	E [Note]			
⑦ Rail type	LSD15:	LSD15:		T: Bottom-mount
	Blank: Top-mount(M4)	U: Top-mount(M3)		
	LSD30:	LSD30:		
	Blank: Top-mount(M6)	U: Top-mount(M8)		
LSD15	LSD30	LSD15	LSD30	

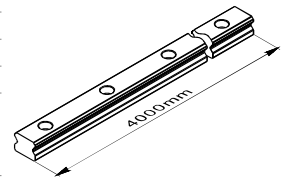

Note: •Standard length of LSD rail is four meters.

- For LSD15, both margin pitch of rail are 20mm. For LSD30, one side of margin pitch is 20mm, the other side is 60mm.
- When selecting rails and bearings, the different pairing codes can change the units preload, details see "preload pairing chart".

(2) LSD20/25/35

LSD 20 RL X 4000 - H - E - T



① Model Code	LSD:Low Profile Type Linear Guide			
② Rail Width	20:20mm 25:23mm 35:34mm			
③ Rail Code	RL: Rail			
④ Rail Length	4000 : 4000mm			
⑤ Accuracy	N : Normal H : High			
⑥ Group Code	E [Note]			
⑦ Rail type	Blank: Top-mount T: Bottom-mount			

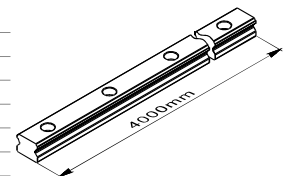

Note: •Standard length of LSD rail is four meters.

- For LSD20/25, both margin pitch of rail are 20mm.
- For LSD35, one side of margin pitch is 20mm, the other side is 60mm.
- When selecting rails and bearings, the different pairing codes can change the units preload, details see "preload pairing chart".

Low Profile Type Linear Guide

LSD Series

3. Rail Order Information

(1) LSD15/30

LSD □ 15 RL X 220-S20 - H - E - U



Note: 1. When selecting rails and bearings, the different pairing codes can change the units preload, details see "preload pairing chart".
2. For LSD-B series, standard length of a rail is 3 m.

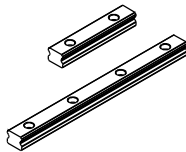

① Model Code	LSD: Low Profile Type Linear Guide			
② Coating on rail	Blank: Rail without additional coating. (natural color) ★B: Rail coated with black chrome			
③ Rail Width	15:15mm 30:28mm			
④ Rail Code	RL: Rail			
⑤ Rail Length	220:220mm[Defined by customer]			
⑥ Position of first mounting hole	S□ : Distance from end of rail to the center of first mounting hole (It is recommended to be greater than minimum margin) [Standard margin pitch is 20mm]			
⑦ Accuracy	N : Normal H : High			
⑧ Group code	E [Note]			
⑨ Rail type	LSD15: Blank: Top-mount(M4)	LSD15: U: Top-mount(M3)	T: Bottom-mount	
	LSD30: Blank: Top-mount(M6)	LSD30: U: Top-mount(M8)		
	LSD15 Φ4.8	LSD30 Φ11.2	LSD15 Φ6	LSD30 Φ14.2

(2) LSD20/25/35

LSD □ 20 RL X 220-S20 - H - E - T



Note: 1. When selecting rails and bearings, the different pairing codes can change the units preload, details see "preload pairing chart".
2. For LSD-B series, standard length of a rail is 3 m.

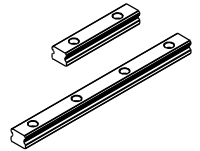

① Model Code	LSD: Low Profile Type Linear Guide		
② Coating on rail	Blank: Rail without additional coating. (natural color) ★B: Rail coated with black chrome		
③ Rail Width	20:20mm 25:23mm 35:34mm		
④ Rail Code	RL: Rail		
⑤ Rail Length	220:220mm[Defined by customer]		
⑥ Position of first mounting hole	S□ : Distance from end of rail to the center of first mounting hole (It is recommended to be greater than minimum margin) [Standard margin pitch is 20mm]		
⑦ Accuracy	N : Normal H : High		
⑧ Group code	E [Note]		
⑨ Rail type	Blank: Top-mount T: Bottom-mount		

4. Rail/Block preload pairing chart

When customer orders rail/block, please choose the pairing code of rail/block in accordance with the needed preload of linear guide(combined). Details please refer to the "preload pairing chart".

Model	Rail pairing code	Block pairing code	Preload grade	Model	Rail pairing code	Block pairing code	Preload grade	Model	Rail pairing code	Block pairing code	Preload grade
LSD15 LSD20 LSD25	E	E	Standard clearance	LSD30	E	E	Standard clearance	LSD35	E	E	Standard clearance
		C	Light preload			C	Light preload			C	Light preload
		SA	Medium preload			SB	Medium preload			SC	Medium preload

Accessory Order Code

L - P - AM6 - □



① Accessory Code	L: Linear Guide Accessory							
② Nipple/adaptor Code	P: Nipple/adaptor							
③ Nipple/adaptor type	15	M4	M4 Nipple	I type	M6	M6 Nipple	I type	
		AM6	M4 to M6		A01	M6 to PT1/8		M6 to M8
	30	LM6	M4 to M6	L type	20	L01	M6 to PT1/8	L type
					25	LM8	M6 to M8	
④ Block type	Blank: Standard ZZ: For LSD15/25/30/35 series highly dustproof block (both DD and ZZ type) ZZLSD20: For LSD20 series highly dustproof block (both DD and ZZ type)							

LSD Series

Rail (4m) Specification

- The maximum length of a single rail is 4,000 mm, please refer to the table for more detail about edge pitch of first mounting hole (S) and last mounting hole (E).
 - The edge pitch of first mounting hole (S) and last mounting hole (E) should not be greater than 1/2P. Overlong edge may induce unstable installation and affect the accuracy.
- n: Numbers of mounting holes

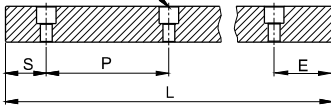

$$L = (n-1) \times P + S + E$$

L: Total length of rail(mm)

n: Numbers of mounting holes on rail

P: Distance between bolt holes(mm)

S: Edge of first mounting hole(mm)

E: Edge of last mounting hole(mm)

Model	LSD15	LSD20	LSD25	LSD30	LSD35
Pitch(P)	60	60	60	80	80
Rail (4m) Standard Edge Pitch(S)	20	20	20	20	20
Rail (4m) Standard Edge Pitch(E)	20	20	20	60	60
Min. Edge Pitch(S/E min)	5(4)	6	7	7(8)	8
Max. Edge Pitch(S/E max)	55(56)	54	53	73(72)	72
Maximum length(Lmax)	4000	4000	4000	4000	4000

Note:

- For LSD15 when it mounted with M3 screw, Min. edge pitch is 4mm, Max. edge pitch is 56mm. For LSD15 when it mounted with M4 screw, Min. edge pitch is 5mm, Max. edge pitch is 55mm.
- For LSD30 when it mounted with M6 screw, Min. edge pitch is 7mm, Max. edge pitch is 73mm. For LSD30 when it mounted with M8 screw, Min. edge pitch is 8mm, Max. edge pitch is 72mm.
- Joint rail must be chosen if length of rail exceeds the maximum.
- When deciding edge pitch, it should be within the range of above table. There would be risk of broken hole if pitch is out of range.
- Maximum length of rail for standard' means the maximum length of rail can be chosen when both sides of edge pitches are standard.

Specifications and Dimensions

Square type

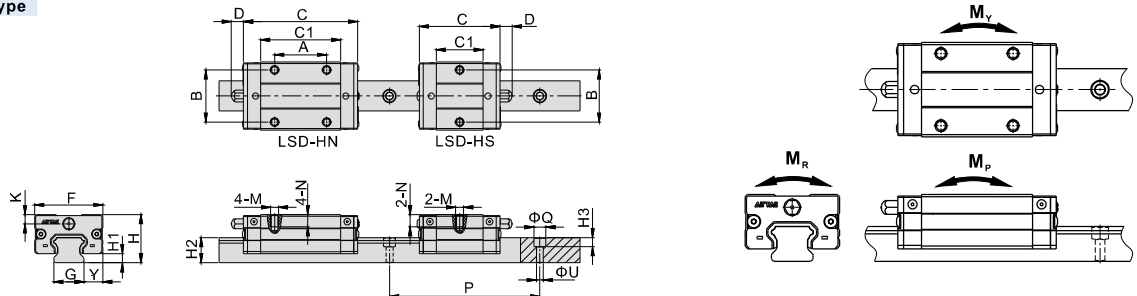

Model/Item	External Dimension (mm)							Block Dimension (mm)							Rail Dimension (mm)					
	H	H1	F	Y	C			C1	A	B	K	D	M	N	G	H2	P	ΦQ[Note]	ΦU	H3
					Standard (Blank)	Double oil scrapers(DD)	Oil scraper+Metal scraper(ZZ)													
LSD15HS	24	4.5	34	9.5	40.5	47.5	45	23.5	-	26	4.6	6	M4X0.7	6	15	12.5	60	8(6)	4.8(3.5)	5.3(4.5)
LSD15HN	24	4.5	34	9.5	57	64	61.5	40	26	26	4.6	6	M4X0.7	6	15	12.5	60	8(6)	4.8(3.5)	5.3(4.5)
LSD20HS	28	6	42	11	46	53	50.5	29	-	32	6.2	13	M5X0.8	7	20	15.5	60	9.5	5.8	8.5
LSD20HN	28	6	42	11	65	72	69.5	48	32	32	6.2	13	M5X0.8	7	20	15.5	60	9.5	5.8	8.5
LSD25HS	33	7	48	12.5	59	66	63.5	36.5	-	35	7.2	13	M6X1.0	9	23	18	60	11.2	7	9
LSD25HN	33	7	48	12.5	83	90	87.5	60.5	35	35	7.2	13	M6X1.0	9	23	18	60	11.2	7	9
LSD30HS	42	9	60	16	68.5	76.5	73.5	41.5	-	40	7.2	13	M8X1.25	12	28	23	80	11.2(14.2)	7(9)	9(12)
LSD30HN	42	9	60	16	97	105	102	70	40	40	7.2	13	M8X1.25	12	28	23	80	11.2(14.2)	7(9)	9(12)
LSD35HS	48	11	70	18	73.5	81.5	78.5	46.5	-	50	8.5	13	M8X1.25	12	34	27.5	80	14.2	9	12
LSD35HN	48	11	70	18	106.5	114.5	111.5	79.5	50	50	8.5	13	M8X1.25	12	34	27.5	80	14.2	9	12

Model/Item	Mounting Screw	Dynamic Load Rating(kN)	Static Load Rating(kN)	Static Rated Moment (kN.m)			Weight	
				C _p	M _r	M _p	M _v	Block(kg)
LSD15HS	M4(M3)	5.0	9.5	0.07	0.04	0.04	0.09	1.23
LSD15HN	M4(M3)	8.9	16.5	0.12	0.10	0.10	0.15	1.23
LSD20HS	M5	7.2	13.5	0.13	0.06	0.06	0.14	2.11
LSD20HN	M5	12.1	22.4	0.20	0.15	0.15	0.23	2.11
LSD25HS	M6	11.5	20.8	0.22	0.11	0.11	0.26	2.76
LSD25HN	M6	19.3	34.7	0.36	0.31	0.31	0.42	2.76
LSD30HS	M6(M8)	19.8	30.0	0.38	0.20	0.20	0.44	4.60
LSD30HN	M6(M8)	28.3	50.3	0.65	0.53	0.53	0.75	4.60
LSD35HS	M8	29.2	40.7	0.66	0.33	0.33	0.74	6.27
LSD35HN	M8	42.7	70.2	1.02	0.72	0.72	1.17	6.27

[Note]: The standard countersink of LSD15 rail is Φ8X5.3XΦ4.8 and with M4 screw. If with M3 screw, the ordering code should add "U", and the countersink is Φ6X4.5XΦ3.5. The standard countersink of LSD30 rail is Φ11.2X9XΦ7 and with M6 screw. If with M8 screw, the ordering code should add "U", and the countersink is Φ14.2X12XΦ9.

Low Profile Type Linear Guide

LSD Series

Flange type, Top-Mount

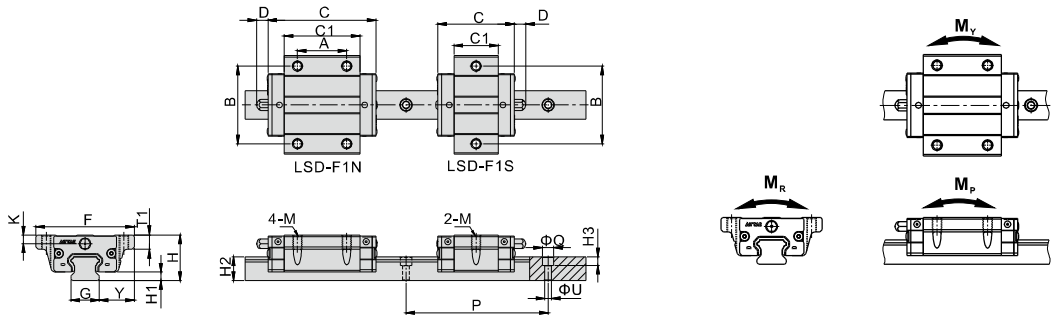

Model/Item	External Dimension (mm)							Block Dimension (mm)							Rail Dimension (mm)					
	H	H1	F	Y	C			C1	A	B	K	D	M	T1	G	H2	P	ΦQ[Note]	ΦU	H3
					Standard (Blank)	Double oil scrapers(DD)	Oil scraper+Metal scraper(ZZ)													
LSD15F1S	24	4.5	52	18.5	40.5	47.5	45	23.5	-	41	4.6	6	M5X0.8	7.5	15	12.5	60	8(6)	4.8(3.5)	5.3(4.5)
LSD15F1N	24	4.5	52	18.5	57	64	61.5	40	26	41	4.6	6	M5X0.8	7.5	15	12.5	60	8(6)	4.8(3.5)	5.3(4.5)
LSD20F1S	28	6	59	19.5	46	53	50.5	29	-	49	6.2	13	M6X1.0	9.5	20	15.5	60	9.5	5.8	8.5
LSD20F1N	28	6	59	19.5	65	72	69.5	48	32	49	6.2	13	M6X1.0	9.5	20	15.5	60	9.5	5.8	8.5
LSD25F1S	33	7	73	25	59	66	63.5	36.5	-	60	7.2	13	M8X1.25	10.5	23	18	60	11.2	7	9
LSD25F1N	33	7	73	25	83	90	87.5	60.5	35	60	7.2	13	M8X1.25	10.5	23	18	60	11.2	7	9
LSD30F1S	42	9	90	31	68.5	76.5	73.5	41.5	-	72	7.2	13	M10X1.5	10.5	28	23	80	11.2(14.2)	7(9)	9(12)
LSD30F1N	42	9	90	31	97	105	102	70	40	72	7.2	13	M10X1.5	10.5	28	23	80	11.2(14.2)	7(9)	9(12)
LSD35F1S	48	11	100	33	73.5	81.5	78.5	46.5	-	82	8.5	13	M10X1.5	13.5	34	27.5	80	14.2	9	12
LSD35F1N	48	11	100	33	106.5	114.5	111.5	79.5	50	82	8.5	13	M10X1.5	13.5	34	27.5	80	14.2	9	12

Model/Item	Mounting Screw	Dynamic Load Rating(kN)	Static Load Rating(kN)	Static Rated Moment (kN.m)			Weight	
				M_r	M_p	M_v	Block(kg)	Rail(kg/m)
LSD15F1S	M4(M3)	5.0	9.5	0.07	0.04	0.04	0.12	1.23
LSD15F1N	M4(M3)	8.9	16.5	0.12	0.10	0.10	0.21	1.23
LSD20F1S	M5	7.2	13.5	0.13	0.06	0.06	0.18	2.11
LSD20F1N	M5	12.1	22.4	0.20	0.15	0.15	0.31	2.11
LSD25F1S	M6	11.5	20.8	0.22	0.11	0.11	0.36	2.76
LSD25F1N	M6	19.3	34.7	0.36	0.31	0.31	0.60	2.76
LSD30F1S	M6(M8)	19.8	30.0	0.38	0.20	0.20	0.61	4.60
LSD30F1N	M6(M8)	28.3	50.3	0.65	0.53	0.53	1.03	4.60
LSD35F1S	M8	29.2	40.7	0.66	0.33	0.33	0.93	6.27
LSD35F1N	M8	42.7	70.2	1.02	0.72	0.72	1.50	6.27

[Note]: The standard countersink of LSD15 rail is $\Phi 8 \times 5.3 \times \Phi 4.8$ and with M4 screw. If with M3 screw, the ordering code should add "U", and the countersink is $\Phi 6 \times 4.5 \times \Phi 3.5$.
The standard countersink of LSD30 rail is $\Phi 11.2 \times 9 \times \Phi 7$ and with M6 screw. If with M8 screw, the ordering code should add "U", and the countersink is $\Phi 14.2 \times 12 \times \Phi 9$.

Low Profile Type Linear Guide

LSD Series

Flange type, Bottom-Mount

Flange type, Top or Bottom-Mount

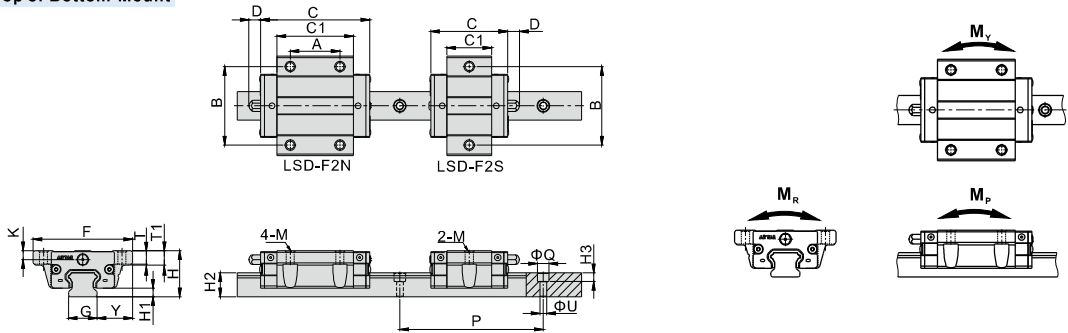

Model/Item	External Dimension (mm)							Block Dimension (mm)						Rail Dimension (mm)								
	H	H1	F	Y	C			C1	A	B	K	D	M		T	T1	G	H2	P	ΦQ [Note]	ΦU [Note]	H3 [Note]
					Standard (Blank)	Double oil scrapers (DD)	Oil scraper +Metal craper (ZZ)						Bottom- Mount	Top or Bottom- Mount								
LSD15F2(F3)S	24	4.5	52	18.5	40.5	47.5	45	23.5	-	41	4.6	6	Φ4.5	M5X0.8	7	7.5	15	12.5	60	8(6)	4.8(3.5)	5.3(4.5)
LSD15F2(F3)N	24	4.5	52	18.5	57	64	61.5	40	26	41	4.6	6	Φ4.5	M5X0.8	7	7.5	15	12.5	60	8(6)	4.8(3.5)	5.3(4.5)
LSD20F2(F3)S	28	6	59	19.5	46	53	50.5	29	-	49	6.2	13	Φ5.7	M6X1.0	9	9.5	20	15.5	60	9.5	5.8	8.5
LSD20F2(F3)N	28	6	59	19.5	65	72	69.5	48	32	49	6.2	13	Φ5.7	M6X1.0	9	9.5	20	15.5	60	9.5	5.8	8.5
LSD25F2(F3)S	33	7	73	25	59	66	63.5	36.5	-	60	7.2	13	Φ6.8	M8X1.25	10	10.5	23	18	60	11.2	7	9
LSD25F2(F3)N	33	7	73	25	83	90	87.5	60.5	35	60	7.2	13	Φ6.8	M8X1.25	10	10.5	23	18	60	11.2	7	9
LSD30F2(F3)S	42	9	90	31	68.5	76.5	79.5	41.5	-	72	7.2	13	Φ9	M10X1.5	10	10.5	28	23	80	11.2(14.2)	7(9)	9(12)
LSD30F2(F3)N	42	9	90	31	97	105	102	70	40	72	7.2	13	Φ9	M10X1.5	10	10.5	28	23	80	11.2(14.2)	7(9)	9(12)
LSD35F2(F3)S	48	11	100	33	73.5	81.5	78.5	46.5	-	82	8.5	13	Φ9	M10X1.5	13	13.5	34	27.5	80	14.2	9	12
LSD35F2(F3)N	48	11	100	33	106.5	114.5	111.5	79.5	50	82	8.5	13	Φ9	M10X1.5	13	13.5	34	27.5	80	14.2	9	12

Model/Item	Mounting Screw	Dynamic Load Rating(kN)	Static Load Rating(kN)	Static Rated Moment (kN.m)			Weight	
				Ca	Mc	My	Block(kg)	Rail(kg/m)
LSD15F2(F3)S	M4(M3)	5.0	9.5	0.07	0.04	0.04	0.12	1.23
LSD15F2(F3)N	M4(M3)	8.9	16.5	0.12	0.10	0.10	0.21	1.23
LSD20F2(F3)S	M5	7.2	13.5	0.13	0.06	0.06	0.18	2.11
LSD20F2(F3)N	M5	12.1	22.4	0.20	0.15	0.15	0.31	2.11
LSD25F2(F3)S	M6	11.5	20.8	0.22	0.11	0.11	0.36	2.76
LSD25F2(F3)N	M6	19.3	34.7	0.36	0.31	0.31	0.60	2.76
LSD30F2(F3)S	M6(M8)	19.8	30.0	0.38	0.20	0.20	0.61	4.60
LSD30F2(F3)N	M6(M8)	28.3	50.3	0.65	0.53	0.53	1.03	4.60
LSD35F2(F3)S	M8	29.2	40.7	0.66	0.33	0.33	0.93	6.27
LSD35F2(F3)N	M8	42.7	70.2	1.02	0.72	0.72	1.50	6.27

[Note]: The standard countersink of LSD15 rail is $\Phi 8 \times 5.3 \times \Phi 4.8$ and with M4 screw. If with M3 screw, the ordering code should add "U", and the countersink is $\Phi 6 \times 4.5 \times \Phi 3.5$.
The standard countersink of LSD30 rail is $\Phi 11.2 \times 9 \times \Phi 7$ and with M6 screw. If with M8 screw, the ordering code should add "U", and the countersink is $\Phi 14.2 \times 12 \times \Phi 9$.

Low Profile Type Linear Guide

LSD Series

Dimension of bottom-mount type rail

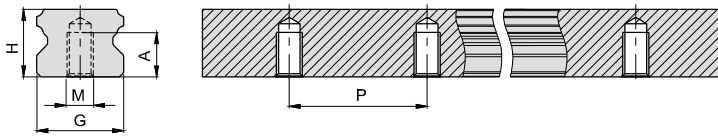

Model/Item	G	H	M	A	P
LSD15T	15	12.5	M5X0.8	7	60
LSD20T	20	15.5	M6X1.0	9	60
LSD25T	23	18	M6X1.0	10	60
LSD30T	28	23	M8X1.25	14	80
LSD35T	34	27.5	M8X1.25	17	80

Accuracy Classes

LSD Low Profile type linear guide comes with 3 accuracy levels.

	Accuracy Standards (mm)						
	Accuracy	N : Normal		H: High		P: Precision	
	Model	15/20	25/30/35	15/20	25/30/35	15/20	25/30/35
Tolerance of height H	±0.1	±0.03	±0.04	±0.015	±0.02		
Variation of height ΔH	0.02	0.025	0.01	0.015	0.006	0.007	
Tolerance of width Y	±0.1	±0.03	±0.04	±0.015	±0.02		
Variation of width ΔY	0.02	0.03	0.01	0.015	0.006	0.007	
Parallelism of C-surface relative to A-surface	Parallelism of raceway (Refer to Table 1)						
Parallelism of D-surface relative to B-surface	Parallelism of raceway (Refer to Table 1)						

Table 1 : Parallelism of the raceway

Accuracy Rail Length(mm)	Parallelism of the raceway(μm)		
	N	H	P
100 under	12	7	3
100~200	14	9	4
200~300	15	10	5
300~500	17	12	6
500~700	20	13	7
700~900	22	15	8
900~1100	24	16	9
1100~1500	26	18	11
1500~1900	28	20	13
1900~2500	31	22	15
2500~3100	33	25	18
3100~3600	36	27	20
3600~4000	37	28	21

Preload Level

1. Preload interference

The LSD Low Profile type Linear Guide has three preload categories: A, B and C.

Choosing suitable preload level will enhance rigidity, precision and torsion resistant performance of the linear guide.

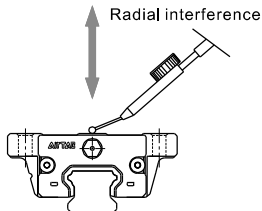

Model	Radial interference(μm)		
	Standard clearance(A)	Light Preload(B)	Middle Preload(C)
LSD15	-4~+2	-12~-4	-22~-14
LSD20	-5~+2	-13~-5	-23~-15
LSD25	-6~+2	-14~-6	-24~-16
LSD30	-7~+2	-16~-7	-29~-20
LSD35	-8~+2	-21~-11	-34~-24

2. Common Application

Refer to following table for suitable application of different preload grade:

Preload grade	Requirement	Common Application
Standard clearance(A)	One axial movement, small vibration and impact, accuracy requirement is low	Conveyor Machine, Semiconductor Equipment, Stage Equipment, Press Machine, Welding Machine and other light movement equipments
Light Preload(B)	Equipment that requires light-load and high-precision.	Z-axis movement for industrial use, NC lathe, EDM, Precision XY platform, Vertical machine center, measurement instrument, material feeder or industrial robot
Medium Preload(C)	Equipment that requires high rigidity, large vibration and shock.	Machining centers, NC lathes, grinders, vertical or horizontal milling machines, boring machines, tool guides, heavy cutting machines.

LSD Series

Installation Illustration

1. Allowable tolerance of mounting surface

LSD series is an arc-shape, two-point contact design of linear guide. Its self-centering feature allows some tolerance on mounting surface without affecting the smoothness of linear motion. The allowable tolerance is indicated in following table:

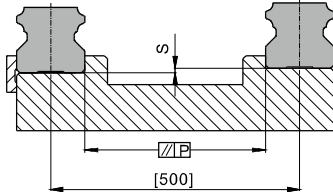

Model	Allowable tolerance of parallelism P(μm)			Allowable tolerance of top and bottom S (μm)		
	Standard clearance(A)	Light Preload(B)	Medium Preload(C)	Standard clearance(A)	Light Preload(B)	Medium Preload(C)
LSD15	25	18	-	130	85	-
LSD20	25	20	18	130	85	50
LSD25	30	22	20	130	85	70
LSD30	40	30	27	170	110	90
LSD35	50	35	30	210	150	120

Note: The value in the table is the allowable value when the distance between the two linear guides is 500mm, and the allowable value is proportional to the distance between the two linear guides.

2. Height and Chamfer of Reference Edge

In order to ensure accurate installation of LSD Linear Guide, the contact space should not exceed the given figures in following table.

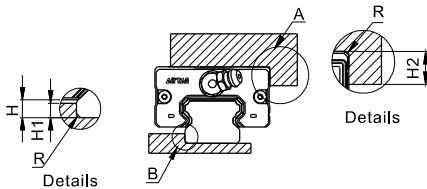

Unit : mm

Model	H	H1	H2	R(Max)
LSD15	4.5	2.7	5	0.5
LSD20	6	5	7	0.5
LSD25	7	5	7.5	1
LSD30	9	7	7	1
LSD35	11	7.5	9.5	1

3. Screw Tighten Torque

When installing linear guide, whether the screws are well tighten and surface is well contacted will affect accuracy significantly. Please refer to following table for tightening force to ensure a perfect installation.

Model	Screw size	Tighten Torque(N.cm)		
		Iron	Casting	Aluminum alloy
LSD15	M3	196	127	98
	M4	412	274	206
LSD20	M5	882	588	441
	M6	1370	921	686
LSD30	M6	1370	921	686
	M8	3040	2010	1470
LSD35	M8	3040	2010	1470

4. Installation and Application

Linear guide installation methods can be divided into the followings.

For installations other than forward installation, the lubricant may fail.

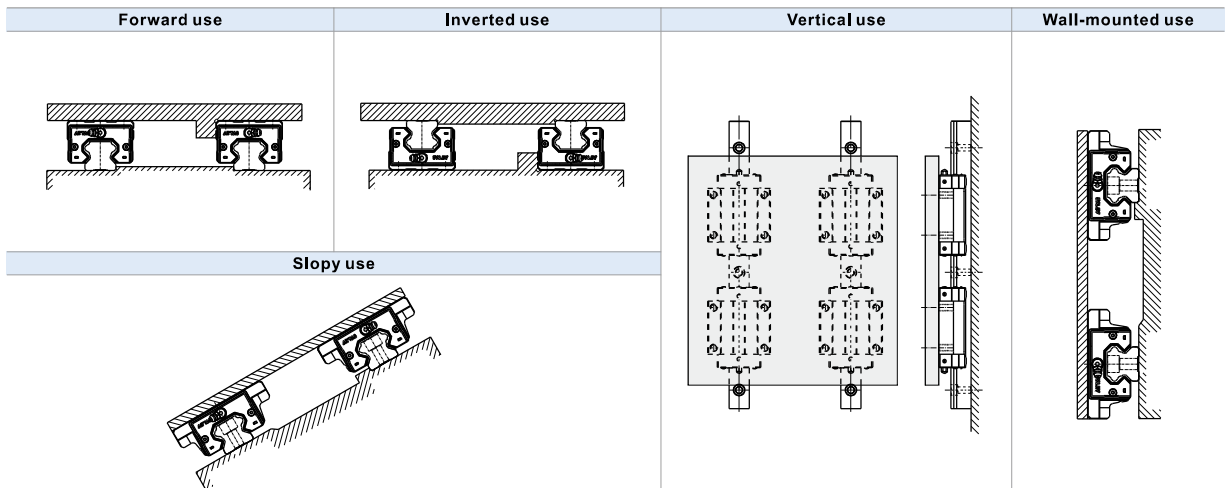

LSD Series

5. Datum plane

- Datum plane for installation must be ground or finely milled to ensure accuracy.
- Both sides of Rail can be used as the datum plane.
- For multi-blocks on a rail, identification line on blocks should be put on the same side to ensure moving accuracy.

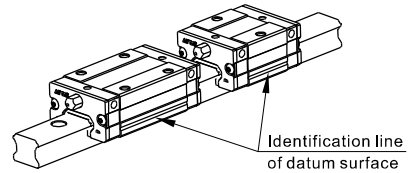

6. Fixation Method

Rails and blocks are possible to be displaced while the machine is subjected to vibrations and impacts thus to affect the accuracy. In order to avoid those difficulties and achieve high running accuracy, the following four methods are recommended for fixing.

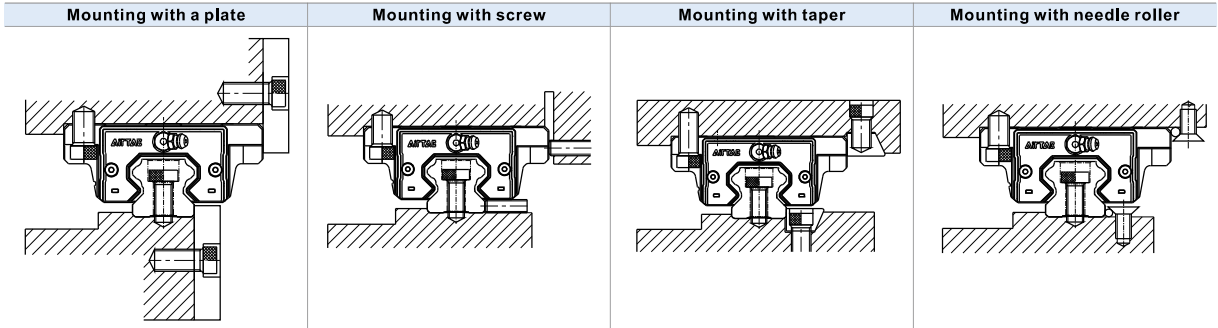

7. Rail Installation

A. Before installing the rail, remove all dirt from the mounting surface with oil stone, and then wipe with a clean cloth.

Remove all dirt from the mounting surface with oil stone, and then wipe with a clean cloth

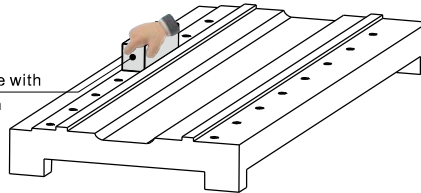

B. Place the rail gently on the bed firstly, then put the bolts into the mounting holes and pre-tighten them, place the rail ① into close contact with the datum plane of the bed by using the baffle, tighten the bolts with appropriate torque to fix the rail. Refer to "3. Screw tighten torque" for recommended torque value.

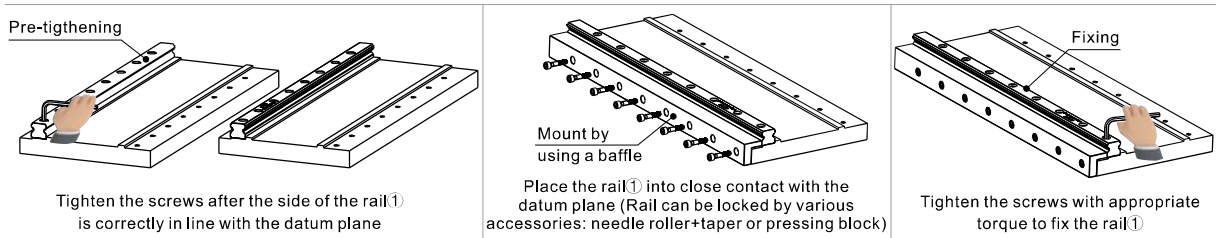

8. Block Installation

- Temporarily fix the table on the block by using the mounting bolts.
- Push the block datum plane against the side datum plane of the table and position the block by tightening the set screws.
- Tighten the mounting bolts in 1 to 4 sequences to fix the table on the block.

9. Subsidiary Rail Installation

Under the condition that the subsidiary rail has a reference datum plane, remove all dirt from the mounting surface with oil stone, and then wipe with a clean cloth, mount the subsidiary rail ② with the same method of the master rail ①.

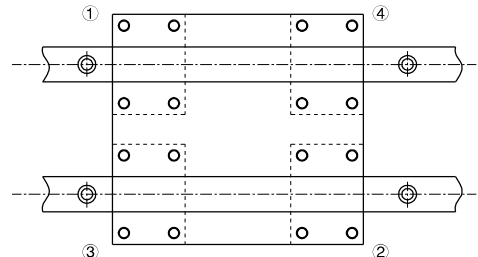
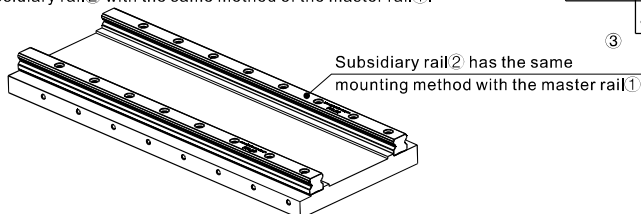

Under the condition that the subsidiary rail ② has a reference datum plane, remove all dirt from the mounting surface with oil stone, and then wipe with a clean cloth,

LSD Series

10. Rail Installation without Side Datum Surface

Using a provisional datum plane

Use the datum plane provided on the bed for straight alignment of the rail from one end to the other, attention must be paid to fix two blocks in close contact on the measuring plate.

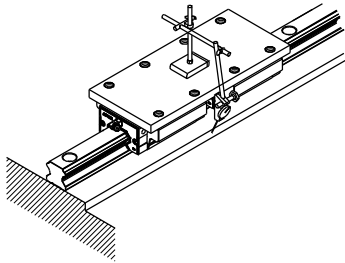

Using a straight-edge

Put the straight-edge between the two rails and use a dial gauge to adjust straight-edge in parallel with the side datum plane of the master rail. Use the dial gauge to ensure the straightness of the subsidiary rail by using the straight-edge as reference, then tighten the mounting bolts in proper sequence when the subsidiary rail is parallel to the master rail.

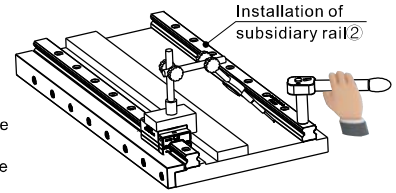

11. Rail Installation without Set Screws

To ensure parallelism between the subsidiary rail and the master rail in the condition without set screws, the following installation methods are recommended, and the installation of the block is the same as mentioned previously.

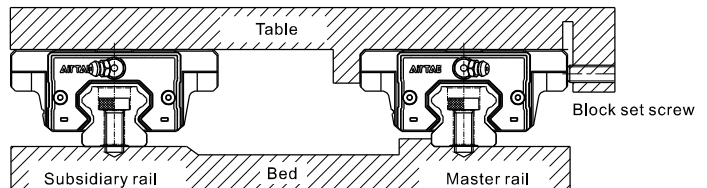

Installation of the master rail

Using a vice

Put the rail on the bed mounting surface and temporarily fasten the mounting bolts, then push the rail against the side datum plane of the bed by using a vice to ensure the rail position. Tighten the mounting bolts in proper sequence with specific torque.

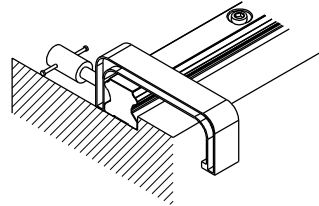

Installation of the subsidiary rail

Using a straight-edge

Put the straight-edge between the two rails and use a dial gauge to adjust straight-edge in parallel with the side datum plane of the master rail. Use the straight-edge to ensure the straightness of the subsidiary rail, then tighten the mounting bolts in proper sequence with specific torque.

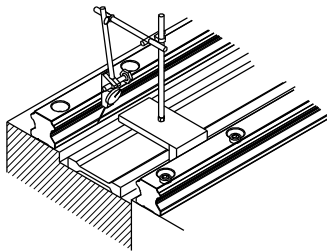

Using a table

Fix two blocks on the master rail to the table, and temporarily fix the subsidiary rail to the bed and one block on the subsidiary rail to the table. Place the gauge against the side surface of the block on the subsidiary rail, move the table from one end of the rail to the other end, then tighten the mounting bolts in proper sequence with specific torque while aligning the subsidiary rail parallel to the master rail.

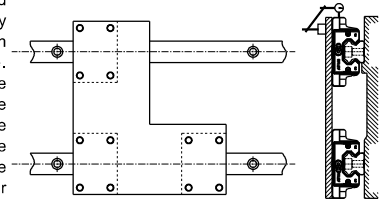

Following the master rail

Fix the table to the master rail and two blocks on the subsidiary rail, temporarily fix the other block on the subsidiary rail to the table and subsidiary rail to the bed. Moving the table from one end of the master rail and tighten the mounting bolts on the subsidiary rail in proper sequence with specific torque at the same time.

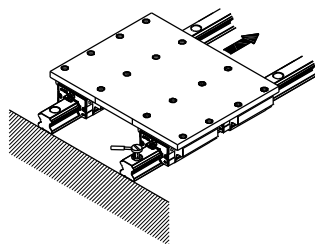

Using a jig

Use a special jig to help ensure the position of the subsidiary rail, and tighten the mounting bolts in proper sequence with specific torque.

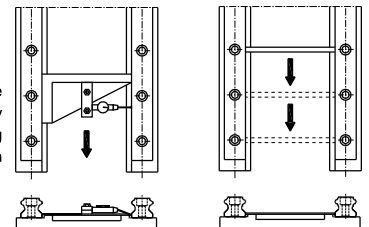

LSD Series

12. Rail Butt-jointed

- When it comes to butt-jointed rail installation, it must follow the butt-jointed marks shown below.
- In order to avoid the accuracy caused by installing the matched jointed rails, it is recommended to stagger the butt-jointed positions, see figure below.

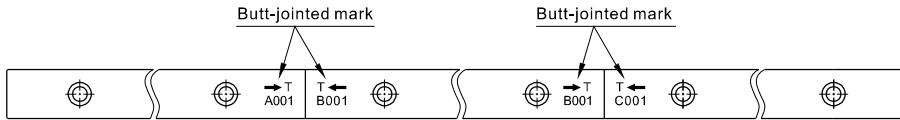

- When jointing rails, it must follow group marks on rail to ensure the accuracy of linear guide. These marks are located on the top surface at joint side. Please put the same group marks together.

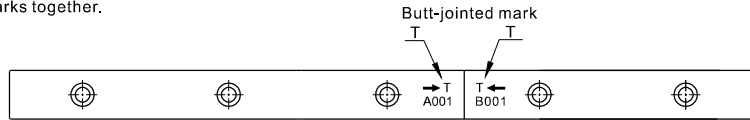

- Be aware serial number of group mark when assemble. A001 and B001 are in a group, so as to A002 and B002 and so on.
- Be aware the installation direction while assembly, the serial numbers are not upside down and arrows point to each other.

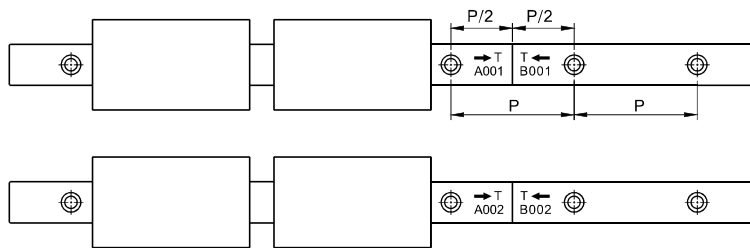

13. Measurement Method after Installation

When measuring running accuracy of the block, two blocks should be fixed on an inspection table in close contact to obtain stable accuracy.

When using a dial gauge, a provisional benchmark (like a straight-edge) is recommended to put as close as possible to the block for accurate measurement.

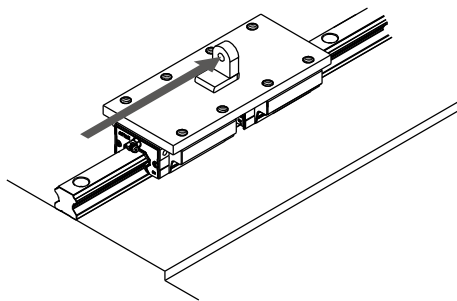

Method using an autocollimator

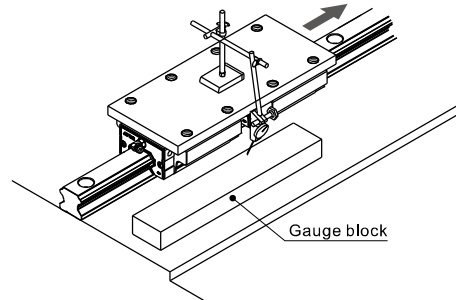

Method using a dial gauge

LSD Series

Lubrication method

When a linear guide is well lubricated, it can reduce wear and increase lifespan significantly. Lubrication has the following benefits :

- Reduces friction of the rollers and raceway to minimize wear.
- The grease film between contact surface can prevent roller fatigue.
- Prevent rust.

1. Lubrication Grease

Use the correct grade of lubrication. While lubricating, a grease gun can be used to pump grease into slider through the grease nipple on it. The suitable condition for lube is when working speed is under 60 m/min and not in cooling process.

•Nipple type

	L-P-M4	L-P-M6	L-P-SM6
Grease nipple type			

•Grease amount

LSD series linear guide is well lubricated with 'Shell Alvania grease S2' in factory. Customers are recommended to use identical or the same grade of lubricant. After lubrication, block needs to be moved back and forth at least three times for the length of three blocks and repeat at least twice. Check if the surface of rail is well covered by grease film.

Model	Grease amount for the first lubrication (cm ³)		Replenishment amount (cm ³)	
	Short type	Standard type	Short type	Standard type
LSD15	0.5	0.9	0.2	0.3
LSD20	1.1	1.8	0.4	0.6
LSD25	1.8	3.2	0.6	1.0
LSD30	2.9	4.5	0.9	1.4
LSD35	4.1	5.9	1.3	1.8

•Lubrication frequency

Although the linear guides are well lubricated at factory and retains grease well, frequent lubrication is still necessary to avoid undesirable wear. Recommended lubrication period is every 100km of movement or every 3~6 months. (Refer to table on the top for suggested amount)

2. Lubricating oil

Recommended oil viscosity for lubrication use is about 30 to 150 cst.

Lubrication oil is suitable for all kinds of load and impact application, but not for high temperature use due to its tendency of vaporization.

•Adaptor

L-P-AM6	L-P-AM8	L-P-A01
	<p>Inner bushing (Use with soft tube, for hard tube is unnecessary)</p>	
LSD15	LSD35 LSD30 LSD25 LSD20	LSD35 LSD30 LSD25 LSD20
L-P-LM6	L-P-LM8	L-P-L01
	<p>Inner bushing (Use with soft tube, for hard tube is unnecessary)</p>	
LSD15	LSD35 LSD30 LSD25 LSD20	LSD35 LSD30 LSD25 LSD20

Note: After installation, the top surface of adaptor may be higher than block. Be careful about the interference while moving.

LSD Series

Lubrication method

•Oil supply rate

Loss of lubrication oil is faster than lubrication grease. Pay attention to sufficiency of oil while using.

Model	Oil amount for the first lubrication(cm ³)	Feeding Speed(cm ³ /hr)
LSD15	0.3	0.1
LSD20	0.5	0.15
LSD25	0.6	0.2
LSD30	0.8	0.25
LSD35	0.9	0.3

3. Grease nipple/adaptor installation

- Grease nipple or adaptor can be installed in the two sides of block for manual or automatic lubrication based on customer's requirement.
- There are a secondary set of lubricating ports on the side of the block. When using, it is not recommended to use the side with datum line unless necessary.
- Lateral nipple installation is not recommended for flange type blocks.
(The grease / oil nipple may interfere with block)
- If lateral lubrication is needed for above spec, please contact us for customization.

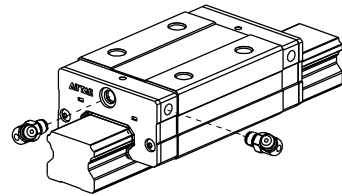

Bolt hole plug

1. Plug type

In order to prevent metal swarf or external objects from entering blocks and affecting precision and lifespan, customers must put plugs into holes during installation. Every rail is equipped with default plugs.

Model	Bolt	Diameter(D)(mm)	Thickness(H)(mm)
LSD15	M3	6.15	1.2
	M4	8.15	1.1
LSD20	M5	9.65	2.5
LSD25	M6	11.4	2.5
LSD30	M6	11.4	2.5
	M8	14.4	3.5
LSD35	M8	14.4	3.5

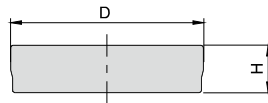

2. Plug installation Steps

Step one



Place the plug in counterbore.

Step two

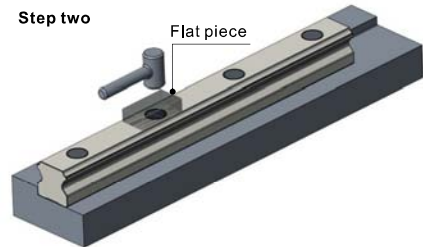

Place the flat piece on mounting hole, hit the piece vertically with a plastic hammer and fix the plug into counterbore.

Note :

- Please make sure the plugs do not protrude the rail surface.
- After installation, please clean the surface before use.

Dustproof standard type linear guide

LSD Series



Order Information(Combined)

1、LSD15/30

LSD □ 15 H N 1 X220 S20 A H-U-AM6-B-T-DD

① ② ③ ④ ⑤ ⑥ ⑦ ⑧ ⑨ ⑩ ⑪ ⑫ ⑬ ⑭ ⑮

① Model Code	LSD:Dustproof standard type linear guide			
② Rail&Block surface treatment	Blank: without additional coating. (natural color) ★BB : Block and rail coated with black chrome			
③ Rail Width	15:15mm		30:28mm	
④ Block Style	H: Square type F1: Flange type, Mounting from top F2: Flange type, Mounting from bottom F3: Flange type, Mounting from top or bottom			
⑤ Block type	S: Short N: Standard			
⑥ Number of Block	1: One 2: Two [Note: Amount of block on a single set of linear guide]			
⑦ Length of Rail	220:220mm[Defined by customer]			
⑧ Position of first mounting hole	S□ : Distance from end of rail to the center of first mounting hole (It is recommended to be greater than minimum margin)			
⑨ Preload	A: Standard clearance B: Light Preload C: Medium Preload			
⑩ Accuracy	N : Normal H : High P : Precision			
⑪ Rail type	LSD15:Blank: Top-mount(M4)		LSD15:U: Top-mount(M3)	
	LSD30:Blank: Top-mount(M6)		LSD30:U: Top-mount(M8)	
⑫ Nipple /adapter type	LSD15: M4: M4 Nipple	LSD15: AM6: M4 to M6	LSD15: LM6: M4 to M6	LSD30: SM6: M6 Nipple
	LSD30: M6: M6 Nipple	LSD30: A01: M6 to PT1/8	LSD30: L01: M6 to PT1/8	
⑬ Packing type	M4	I type	L type	SM6
	M6			
⑭ Rail type	Blank: Top-mount T: Bottom-mount			
⑮ Dust proof	DD: Double oil scrapers ZZ: Oil scraper + metal scraper			

[Note1] For LSD-BB series, standard length of a rail is 3 m.

Please contact with our company if length of rail exceeds the maximum.





Add: Rail type indicated in ⑩ and ⑪ in ordering code cannot be selected at the same time, only one of them can be selected.

LSD Series

2. LSD20/25/35

LSD □ 20 H N 1 X220 S20 A H - AM8-B - T-DD

① ② ③ ④ ⑤ ⑥ ⑦ ⑧ ⑨ ⑩ ⑪ ⑫ ⑬ ⑭

① Model Code	LSD:Dustproof standard type linear guide			
② Rail&Block surface treatment	Blank: without additional coating. (natural color) ★BB : Block and rail coated with black chrome			
③ Rail Width	20:20mm 25:23mm 35:34mm			
④ Block Style	H: Square type F1: Flange type, Mounting from top F2: Flange type, Mounting from bottom F3: Flange type, Mounting from top or bottom			
⑤ Block type	S: Short N: Standard			
⑥ Number of Block	1: One 2: Two [Note: Amount of block on a single set of linear guide]			
⑦ Length of Rail	220:220mm[Defined by customer]			
⑧ Position of first mounting hole	S□ : Distance from end of rail to the center of first mounting hole (It is recommended to be greater than minimum margin)			
⑨ Preload	A: Standard clearance B: Light Preload C: Medium Preload			
⑩ Accuracy	N : Normal H : High P : Precision			
⑪ Nipple /adapter type	M6:M6 Nipple	A01:M6 to PT1/8 AM8:M6 to M8	L01:M6 to PT1/8 LM8:M6 to M8	SM6: M6 Nipple
		I type 	L type 	SM6 
⑫ Packing type	Blank: the block and rail are assembled B: block and rail are put separately			
⑬ Rail type	Blank: Top-mount T: Bottom-mount			
⑭ Dust proof	DD: Double oil scrapers ZZ: Oil scraper + metal scraper			

[Note1] For LSD-BB series, standard length of a rail is 3 m.
Please contact with our company if length of rail exceeds the maximum.

Dustproof standard type linear guide

LSD Series

Butt-jointed Order Information

1、LSD15/30

LSD □ 15 H N 1X2970 T 2940T2970 A H-U-AM6-B -T -DD

① ② ③ ④ ⑤ ⑥ ⑦ ⑧ ⑨ ⑩ ⑪ ⑫ ⑬ ⑭ ⑮ ⑯ ⑰ ⑱

Butt-jointed end margin:1/2P ,
Position of the first and last
hole is defined by customer.

① Model Code	LSD:Dustproof standard type linear guide			
② Rail&Block surface treatment	Blank: without additional coating. (natural color) ★BB : Block and rail coated with black chrome			
③ Rail Width	15:15mm 30:28mm			
④ Block Style	H: Square type F1: Flange type, Mounting from top F2: Flange type, Mounting from bottom F3: Flange type, Mounting from top or bottom			
⑤ Block type	S: Short N: Standard			
⑥ Number of Block	1: One 2: Two [Note: Amount of block on a single set of linear guide]			
⑦ Length of first Rail	2970:2970mm[Defined by customer]			
⑧ Butt-jointed mark	T: Rail Butt-jointed mark(Butt-jointed end margin:1/2P) [P is the standard hole distance]			
⑨ Length of second Rail	2940:2940mm[Defined by customer]			
⑩ Butt-jointed mark	Blank: two rails joint T: Rail Butt-jointed mark (Butt-jointed end margin:1/2P) [P is the standard hole distance]			
⑪ Length of third Rail	Blank: two rails joint 2970:2970mm...[Defined by the customer]			
⑫ Preload	A: Standard clearance B: Light Preload C: Medium Preload			
⑬ Accuracy	N : Normal H : High			
⑭ Rail type	LSD15:Blank: Top-mount(M4)		LSD15:U: Top-mount(M3)	
	LSD30:Blank: Top-mount(M6)		LSD30:U: Top-mount(M8)	
⑮ Nipple /adapter type	LSD15: M4: M4 Nipple		LSD15: AM6: M4 to M6	
	LSD30: M6: M6 Nipple		LSD15: LM6: M4 to M6	
	LSD30: A01: M6 to PT1/8		LSD30: L01: M6 to PT1/8	
	LSD30: AM8: M6 to M8		LSD30: LM8: M6 to M8	
⑯ Packing type	Blank: the block and rail are assembled B: block and rail are put separately			
⑰ Rail type	Blank: Top-mount T: Bottom-mount			
⑱ Dust proof	DD: Double oil scrapers ZZ: Oil scraper + metal scraper			

- [Note1] For LSD-BB series, standard length of a rail is 3 m.
Maximum length of two-joint rail is 6 m.
Maximum length of three-joint rail is 9 m.
Please contact with our company if length of rail exceeds the maximum.
- Add 1: Number of joints cannot be more than 2 times(three rails at most).
For LSD15, maximum length of jointed rail is 11800mm.
For LSD30, it's 11880.
Customization is needed for joint times more than standard.
- Add2 :Rail type indicated in ⑭ and ⑮ in ordering code cannot be selected at the same time, only one of them can be selected.

Dustproof standard type linear guide





LSD Series

2、LSD20/25/35

LSD □ 20 H N 1X2970T2940T2970A H-AM8-B -T-DD

① ② ③ ④ ⑤ ⑥ ⑦ ⑧ ⑨ ⑩ ⑪ ⑫ ⑬ ⑭ ⑮ ⑯ ⑰

Butt-jointed end margin: 1/2P .
Position of the first and last hole is defined by customer.

① Model Code	LSD:Dustproof standard type linear guide			
② Rail&Block surface treatment	Blank: without additional coating. (natural color) ★BB : Block and rail coated with black chrome			
③ Rail Width	20:20mm	25:23mm	35:34mm	
④ Block Style	H: Square type F1: Flange type, Mounting from top F2: Flange type, Mounting from bottom F3: Flange type, Mounting from top or bottom			
⑤ Block type	S: Short N: Standard			
⑥ Number of Block	1: One 2: Two [Note: Amount of block on a single set of linear guide]			
⑦ Length of first Rail	2970:2970mm[Defined by customer]			
⑧ Butt-jointed mark	T: Rail Butt-jointed mark (Butt-jointed end margin:1/2P) [P is the standard hole distance]			
⑨ Length of second Rail	2940:2940mm[Defined by customer]			
⑩ Butt-jointed mark	Blank: two rails joint T: Rail Butt-jointed mark (Butt-jointed end margin:1/2P) [P is the standard hole distance]			
⑪ Length of third Rail	Blank: two rails joint 2970:2970mm..[Defined by the customer]			
⑫ Preload	A: Standard clearance B: Light Preload C: Medium Preload			
⑬ Accuracy	N : Normal H : High			
⑭ Nipple /adapter type	M6: M6 Nipple	A01: M6 to PT1/8 AM8: M6 to M8	L01: M6 to PT1/8 LM8: M6 to M8	SM6: M6 Nipple
		I type 	L type 	SM6 
⑮ Packing type	Blank: the block and rail are assembled B: block and rail are put separately			
⑯ Rail type	Blank: Top-mount T: Bottom-mount			
⑰ Dust proof	DD: Double oil scrapers ZZ: Oil scraper + metal scraper			

[Note1] For LSD-BB series, standard length of a rail is 3 m.
Maximum length of two-joint rail is 6 m.
Maximum length of three-joint rail is 9 m.
Please contact with our company if length of rail exceeds the maximum.
Add: Number of joints cannot be more than 2 times(three rails at most).
For LSD20/25, maximum length of jointed rail is 11800mm.
For LSD35, it's 11880.
Customization is needed for joint times more than standard.

Dustproof standard type linear guide

LSD Series

1. Block Order Information

LSD □ 15 BK - H N - H - E - AM6-DD

① ② ③ ④ ⑤ ⑥ ⑦ ⑧ ⑨ ⑩

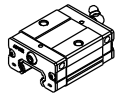

S: Short

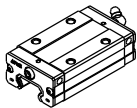

N: Standard

① Model Code	LSD:Dustproof standard type linear guide							
② Coating on block	Blank: Block without additional coating. (natural color) *B: Block coated with black chrome							
③ Rail Width	15:15mm	20:20mm	25:23mm	30:28mm	35:34mm			
④ Block Code	BK: Block							
⑤ Block Style	H: Square type			F1: Flange type, Mounting from top				
				F2: Flange type, Mounting from bottom				
				F3: Flange type, Mounting from top or bottom				
⑥ Block type	S: Short N: Standard							
⑦ Accuracy	N: Normal H: High							
⑧ Group code	SA SB SC C E [Note]							
⑨ Nipple /adapter type	15	M4	M4 Nipple		M6	M6 Nipple		
		AM6	M4 to M6	I type	20	A01	M6 to PT1/8	I type
					25	AM8	M6 to M8	
					30	L01	M6 to PT1/8	L type
					35	LM8	M6 to M8	
			LM6	M4 to M6		SM6	M6 Nipple	
⑩ Dust proof	DD: Double oil scrapers ZZ: Oil scraper + metal scraper							

[Note] When selecting rails and bearings, the different pairing codes can change the units preload, details see "preload pairing chart".

LSD Series

Dust prevention illustration

1. Code and structure

AirTAC provides the following dust prevention accessories for the linear guides working in dusty environment, if the following accessories are demanded, please add the corresponding code when ordering.

Code	Blank: Standard	DD: Double oil scrapers	ZZ: Metal scraper + Oil scraper
Structure	<p>Top seal Side seal Oil scraper</p>	<p>Top seal Side seal (Enhanced) Double oil scrapers (Double lips, enhanced)</p>	<p>Top seal Side seal (Enhanced) oil scrapers (Double lips, enhanced) Metal scraper</p>

2. Test for high dust prevention

2.1. Test item

Test medium	Wood chip	Iron filing	Gravel
Running distance	500km	500km	500km

2.2. Test equipment

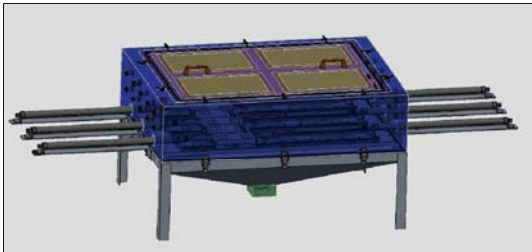

Figure1: Dust tester (Appearance)



Figure2: Dust tester (Inside)

2.3. Test condition

AirTAC adopts the industry's first dust tester (Figure 1) to simulate real working conditions, 360° without dead angles, all-round dust invasion (Figure 2). The dustproof test simulates multiple application scenarios, fully fill the air with wood chips, iron filings and gravels and are strictly tested to ensure the quality and dustproof effect of each block.

2.4. Test result

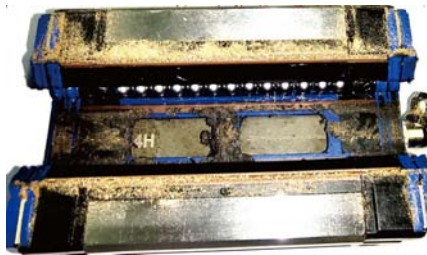

Figure3: Steel balls



Figure4: Steel balls

Result: It can be seen from the Figure 3 and 4 that little amount of dust enters the inside of the block after testing, and the steel ball surface is still smooth, the block still runs smoothly and the performance is not affected.

Note: The above test results are obtained from AirTAC lab.

3. Dimensions

Highly dustproof type blocks have different length compared with the standard blocks (only dimension C is different from the standard, the others keep same), see the table on the right for details.

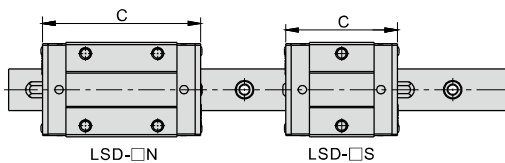

Model	Type	Length C(mm)		
		Standard (Blank)	Double oil scrapers(DD)	Oil scraper+Metal scraper(ZZ)
LSD15□S	Short	40.5	47.5	45
LSD15□N	Standard	57	64	61.5
LSD20□S	Short	46	53	50.5
LSD20□N	Standard	65	72	69.5
LSD25□S	Short	59	66	63.5
LSD25□N	Standard	83	90	87.5
LSD30□S	Short	68.5	76.5	73.5
LSD30□N	Standard	97	105	102
LSD35□S	Short	73.5	81.5	78.5
LSD35□N	Standard	106.5	114.5	111.5

Self-lubricator Standard Linear Guide

LSD Series



Order Information(Combined)

1、LSD15/30

LSD □ 15 H N 1 X220 S20 A H-U-AM6-B-T-E

① ② ③ ④ ⑤ ⑥ ⑦ ⑧ ⑨ ⑩ ⑪ ⑫ ⑬ ⑭ ⑮

① Model Code	LSD:Self-lubricator Standard Linear Guide			
② Rail&Block surface treatment	Blank: without additional coating, (natural color) ★BB : Block and rail coated with black chrome			
③ Rail Width	15:15mm		30:28mm	
④ Block Style	H: Square type F1: Flange type, Mounting from top F2: Flange type, Mounting from bottom F3: Flange type, Mounting from top or bottom			
⑤ Block type	S: Short N: Standard			
⑥ Number of Block	1: One 2: Two [Note: Amount of block on a single set of linear guide]			
⑦ Length of Rail	220:220mm[Defined by customer]			
⑧ Position of first mounting hole	S□ : Distance from end of rail to the center of first mounting hole (It is recommended to be greater than minimum margin)			
⑨ Preload	A: Standard clearance B: Light Preload C: Medium Preload			
⑩ Accuracy	N : Normal H : High P : Precision			
⑪ Rail type	LSD15:Blank: Top-mount(M4)		LSD15:U: Top-mount(M3)	
	LSD30:Blank: Top-mount(M6)		LSD30:U: Top-mount(M8)	
⑫ Nipple /adapter type	LSD15: M4: M4 Nipple	LSD15: AM6: M4 to M6	LSD15: LM6: M4 to M6	LSD30: SM6: M6 Nipple
	LSD30: M6: M6 Nipple	LSD30: A01: M6 to PT1/8	LSD30: L01: M6 to PT1/8	
⑬ Packing type	M4	I type	L type	SM6
	M6			
⑭ Rail type	Blank: the block and rail are assembled B: block and rail are put separately			
⑮ Self-lubricator Standard Type	Blank: Top-mount T: Bottom-mount			
	E:Self-lubricator Standard Type			

[Note] For LSD-BB series, standard length of a rail is 3 m.

Please contact with our company if length of rail exceeds the maximum.





Add: Rail type indicated in ⑩ and ⑪ in ordering code cannot be selected at the same time, only one of them can be selected.

LSD Series

2. LSD20/25/35

LSD □ 20 H N 1 X220 S20 A H – AM8-B – T-E

① ② ③ ④ ⑤ ⑥ ⑦ ⑧ ⑨ ⑩ ⑪ ⑫ ⑬ ⑭

① Model Code	LSD:Self-lubricator Standard Linear Guide			
② Rail&Block surface treatment	Blank: without additional coating, (natural color) ★BB : Block and rail coated with black chrome			
③ Rail Width	20:20mm 25:23mm 35:34mm			
④ Block Style	H: Square type F1: Flange type, Mounting from top F2: Flange type, Mounting from bottom F3: Flange type, Mounting from top or bottom			
⑤ Block type	S: Short N: Standard			
⑥ Number of Block	1: One 2: Two [Note: Amount of block on a single set of linear guide]			
⑦ Length of Rail	220:220mm[Defined by customer]			
⑧ Position of first mounting hole	S□ : Distance from end of rail to the center of first mounting hole (It is recommended to be greater than minimum margin)			
⑨ Preload	A: Standard clearance B: Light Preload C: Medium Preload			
⑩ Accuracy	N : Normal H : High P : Precision			
⑪ Nipple /adapter type	M6:M6 Nipple	A01:M6 to PT1/8 AM8:M6 to M8	L01:M6 to PT1/8 LM8:M6 to M8	SM6: M6 Nipple
		I type 	L type 	SM6 
⑫ Packing type	Blank: the block and rail are assembled B: block and rail are put separately			
⑬ Rail type	Blank: Top-mount T: Bottom-mount			
⑭ Self-lubricator Standard Type	E:Self-lubricator Standard Type			

[Note] For LSD-BB series, standard length of a rail is 3 m.
Please contact with our company if length of rail exceeds the maximum.

Self-lubricator Standard Linear Guide



LSD Series

Butt-jointed Order Information

1、LSD15/30

LSD □ 15 H N 1X2970 T 2940T2970 A H-U-AM6-B -T -E

① ② ③ ④ ⑤ ⑥ ⑦ ⑧ ⑨ ⑩ ⑪ ⑫ ⑬ ⑭ ⑮ ⑯ ⑰ ⑱

Butt-jointed end margin:1/2P ,
Position of the first and last
hole is defined by customer.

① Model Code	LSD:Self-lubricator Standard Linear Guide			
② Rail&Block surface treatment	Blank: without additional coating. (natural color) ★BB : Block and rail coated with black chrome			
③ Rail Width	15:15mm		30:28mm	
④ Block Style	H: Square type F1: Flange type, Mounting from top F2: Flange type, Mounting from bottom F3: Flange type, Mounting from top or bottom			
⑤ Block type	S: Short N: Standard			
⑥ Number of Block	1: One		2: Two [Note: Amount of block on a single set of linear guide]	
⑦ Length of first Rail	2970:2970mm[Defined by customer]			
⑧ Butt-jointed mark	T: Rail Butt-jointed mark(Butt-jointed end margin:1/2P) [P is the standard hole distance]			
⑨ Length of second Rail	2940:2940mm[Defined by customer]			
⑩ Butt-jointed mark	Blank: two rails joint T: Rail Butt-jointed mark (Butt-jointed end margin:1/2P) [P is the standard hole distance]			
⑪ Length of third Rail	Blank: two rails joint 2970:2970mm..[Defined by the customer]			
⑫ Preload	A: Standard clearance B: Light Preload C: Medium Preload			
⑬ Accuracy	N : Normal H : High			
⑭ Rail type	LSD15:Blank: Top-mount(M4)		LSD15:U: Top-mount(M3)	
	LSD30:Blank: Top-mount(M6)		LSD30:U: Top-mount(M8)	
⑮ Nipple /adapter type	LSD30: M6: M6 Nipple		LSD30: L01: M6 to PT1/8	
⑯ Packing type	Blank: the block and rail are assembled B: block and rail are put separately			
⑰ Rail type	Blank: Top-mount		T: Bottom-mount	
⑱ Self-lubricator Standard Type	E:Self-lubricator Standard Type			

[Note]For LSD-BB series, standard length of a rail is 3 m.

Maximum length of two-joint rail is 6 m. Maximum length of three-joint rail is 9 m.

Please contact with our company if length of rail exceeds the maximum.

Add : Number of joints cannot be more than 2 times(three rails at most).

For LSD15, maximum length of jointed rail is 11800mm.

For LSD30, it's 11880.

Customization is needed for joint times more than standard.

Add2 :Rail type indicated in ⑭ and ⑮ in ordering code cannot be selected at the same time, only one of them can be selected.



Self-lubricator Standard Linear Guide





LSD Series

2、LSD20/25/35

LSD □ 20 H N 1X2970T2940T2970A H-AM8-B-T-E

① ② ③ ④ ⑤ ⑥ ⑦ ⑧ ⑨ ⑩ ⑪ ⑫ ⑬ ⑭ ⑮ ⑯ ⑰

Butt-jointed end margin:1/2P ,
Position of the first and last
hole is defined by customer.

① Model Code	LSD:Self-lubricator Standard Linear Guide			
② Rail&Block surface treatment	Blank: without additional coating. (natural color) ★BB : Block and rail coated with black chrome			
③ Rail Width	20:20mm	25:23mm	35:34mm	
④ Block Style	H: Square type F1: Flange type, Mounting from top F2: Flange type, Mounting from bottom F3: Flange type, Mounting from top or bottom			
⑤ Block type	S: Short N: Standard			
⑥ Number of Block	1: One 2: Two [Note: Amount of block on a single set of linear guide]			
⑦ Length of first Rail	2970:2970mm[Defined by customer]			
⑧ Butt-jointed mark	T: Rail Butt-jointed mark (Butt-jointed end margin:1/2P) [P is the standard hole distance]			
⑨ Length of second Rail	2940:2940mm[Defined by customer]			
⑩ Butt-jointed mark	Blank: two rails joint T: Rail Butt-jointed mark (Butt-jointed end margin:1/2P) [P is the standard hole distance]			
⑪ Length of third Rail	Blank: two rails joint 2970:2970mm..[Defined by the customer]			
⑫ Preload	A: Standard clearance B: Light Preload C: Medium Preload			
⑬ Accuracy	N : Normal H : High			
⑭ Nipple /adapter type	M6: M6 Nipple	A01: M6 to PT1/8 AM8: M6 to M8	L01: M6 to PT1/8 LM8: M6 to M8	SM6: M6 Nipple
		I type 	L type 	SM6 
⑮ Packing type	Blank: the block and rail are assembled B: block and rail are put separately			
⑯ Rail type	Blank: Top-mount T: Bottom-mount			
⑰ Self-lubricator Standard Type	E:Self-lubricator Standard Type			

[Note]For LSD-BB series, standard length of a rail is 3 m.

Maximum length of two-joint rail is 6 m. Maximum length of three-joint rail is 9 m.

Please contact with our company if length of rail exceeds the maximum.

Add: Number of joints cannot be more than 2 times(three rails at most).

For LSD20/25, maximum length of jointed rail is 11800mm.

For LSD35, it's 11880.

Customization is needed for joint times more than standard.

LSD Series

1. Block Order Information

LSD □ 15 BK - H N - H - E - AM6-E

① ② ③ ④ ⑤ ⑥ ⑦ ⑧ ⑨ ⑩

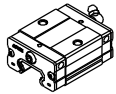

S: Short

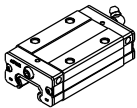

N: Standard

① Model Code	LSD:Self-lubricator Standard Linear Guide							
② Rail&Block surface treatment	Blank: Block without additional coating. (natural color) ★B: Block coated with black chrome							
③ Rail Width	15:15mm	20:20mm	25:23mm	30:28mm	35:34mm			
④ Block Code	BK: Block							
⑤ Block Style	H: Square type F1: Flange type, Mounting from top F2: Flange type, Mounting from bottom F3: Flange type, Mounting from top or bottom							
⑥ Block type	S: Short N: Standard							
⑦ Accuracy	N: Normal H: High							
⑧ Group code	SA SB SC C E [Note1]							
⑨ Nipple /adapter type	15	M4	M4 Nipple		M6	M6 Nipple		
		AM6	M4 to M6	I type	A01	M6 to PT1/8	I type	
		LM6	M4 to M6	L type	20	AM8	M6 to M8	
				L type	25	L01	M6 to PT1/8	L type
30	LM8	M6 to M8						
	35	SM6	M6 Nipple					
⑩ Self-lubricator Standard Type	E:Self-lubricator Standard Type							

[Note1] When selecting rails and bearings, the different pairing codes can change the units preload, details see "preload pairing chart".

LSD Series

Self-lubricator illustration

1.Code and structure

AirTAC provides self-lubricator for applications e.g. limited spaces, or where grease maintenance is challenging.

If needed, please add the code "E" after the product model.

E.g. LSD15HN1X220S20AH-AM6 - B - T - E

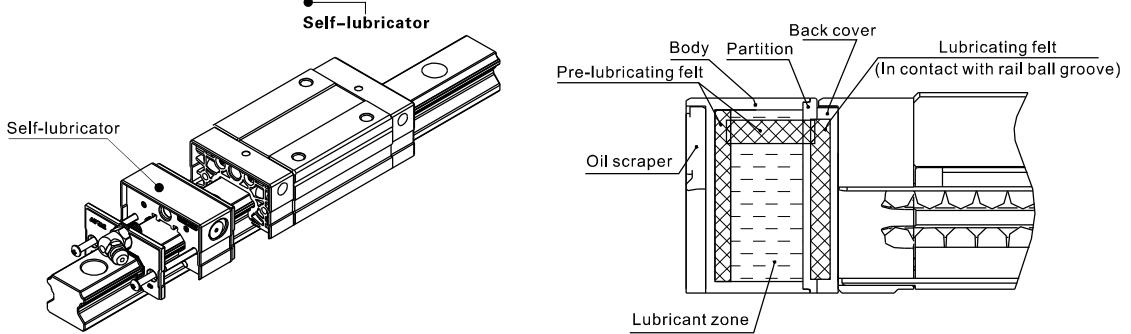

Product Features

1. Easy Maintenance and Long-Term Maintenance-Free Operation: In normal applications, basically no additional grease maintenance is required throughout lifespan of linear guide.
 2. Cost Savings: No additional lubrication is needed for the block, reducing labor and material costs.
 3. Flexible Use in Specific Environments: Equipped with a high-capacity grease tank, allowing the use of specific lubricants for specific environments.
 4. Dustproof Design: Built-in dustproof structure extends lifespan.
 5. Flexible in usage and installation: the assembling and disassembling of self-lubricator in integrity structure is convenient, can have it according to different working condition.
- [Note] Self-lubricator type block is not applicable for ultra-smooth application, as the higher viscosity of the lubricant in self-lubricator will increase friction by approximately 5-7N.

Durability test of self-lubricator

Test specification	Test specification	Model	Speed	Stroke	Lubricant type
■	Lubricating effect	LSD20	30m/min	1200mm	ISO VG680 high-quality extreme pressure lubricant

■ Test result

Test result shows that after running 1,000 km, only 20% of the grease is consumed, and the linear guide remains lubricated. The expected service life can possibly exceed 4,000 km.

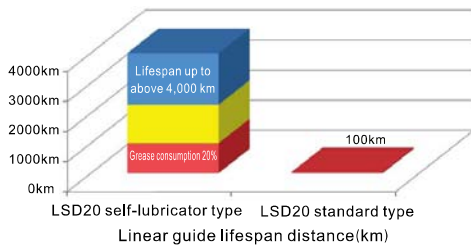

When comparing each sub-series with the self-lubricator and the standard model, the length of block will change. Please refer to the table below for details.

- Block dimension comparison (only dimension C is different from the standard, the rest remains the same)

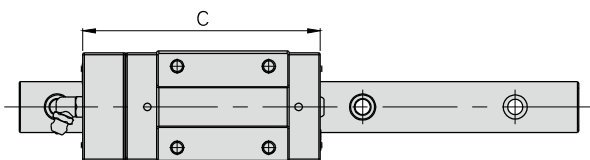

Model	Type	Length C(mm)	
		Standard (Blank)	Self-lubricator Standard Type
LSD15□S	Short	40.5	55
LSD15□N	Standard	57	71.5
LSD20□S	Short	46	62
LSD20□N	Standard	65	81
LSD25□S	Short	59	75
LSD25□N	Standard	83	99
LSD30□S	Short	68.5	84.5
LSD30□N	Standard	97	113
LSD35□S	Short	73.5	89.5
LSD35□N	Standard	106.5	122.5

Precautions on use

1. Block disassembly

With ball retainers and a dustproof cover, normally the balls are prevented from falling out when block is removed from rail. However, if obliquely insert rail into blocks or quickly assembled or disassembled, there is a risk for balls of falling out. Please carefully assemble the linear guide or use plastic rails to assist.

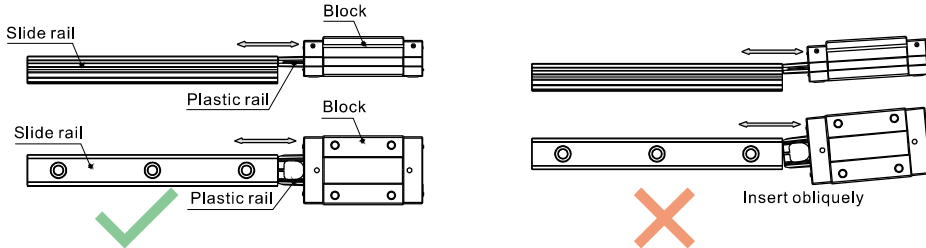

2. Plastic rail installation

A plastic rail is equipped for block set. Please do not remove plastic rail whenever it is not necessary. If plastic rail falls out and needs to be reinstalled, press the dustproof covers with fingers and install slowly to prevent balls from falling out due to misalignment of plastic rail.

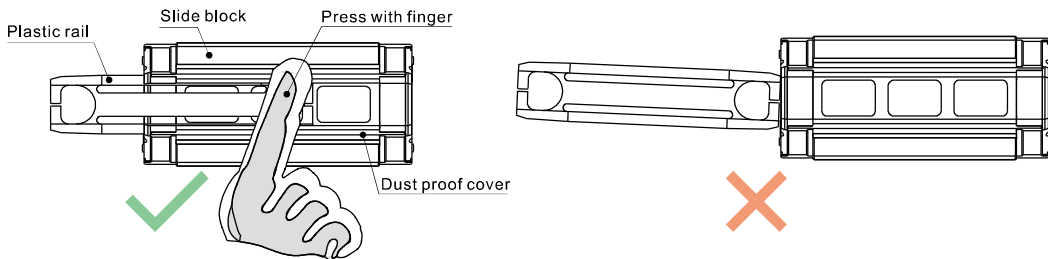

Press the dust-proof covers and insert plastic rail in alignment.

Without pressing dust-proof covers or insert plastic rail obliquely.

3. Caution

- Parts may slide out if linear guide is put unevenly. Please be careful.
- Hitting or dropping linear guide could have huge effect on accuracy and lifespan even though appearance may remain intact. Please be careful.
- Do not disassemble linear guide as external objects may enter blocks and cause accuracy problem.

4. Lubrication

- Linear guide have been treated with anti-rust oil during production. Before use, wipe the rail and treat it with lubrication.
- Do not mix lubricating oil (grease) with different properties.
- After lubrication, move block back and forth for the length of three blocks long and repeat at least 2 times to ensure there is a grease file on rail.

5. Use

- The operating environment temperature should not exceed 80°C, and the maximum temperature should not exceed 100°C.
- Do not separate blocks from rail whenever it is not necessary. If you need to separate them, please use plastic rails to prevent steel balls from falling out.

6. Storage

- When storing blocks, rails or linear guide set, please be sure that anti-rust oil is well applied and product is well sealed as well as placed horizontally. Avoid humidity and high temperatures environment.



LSQH Series Caged Ball Type Linear Guide

Product Introduction

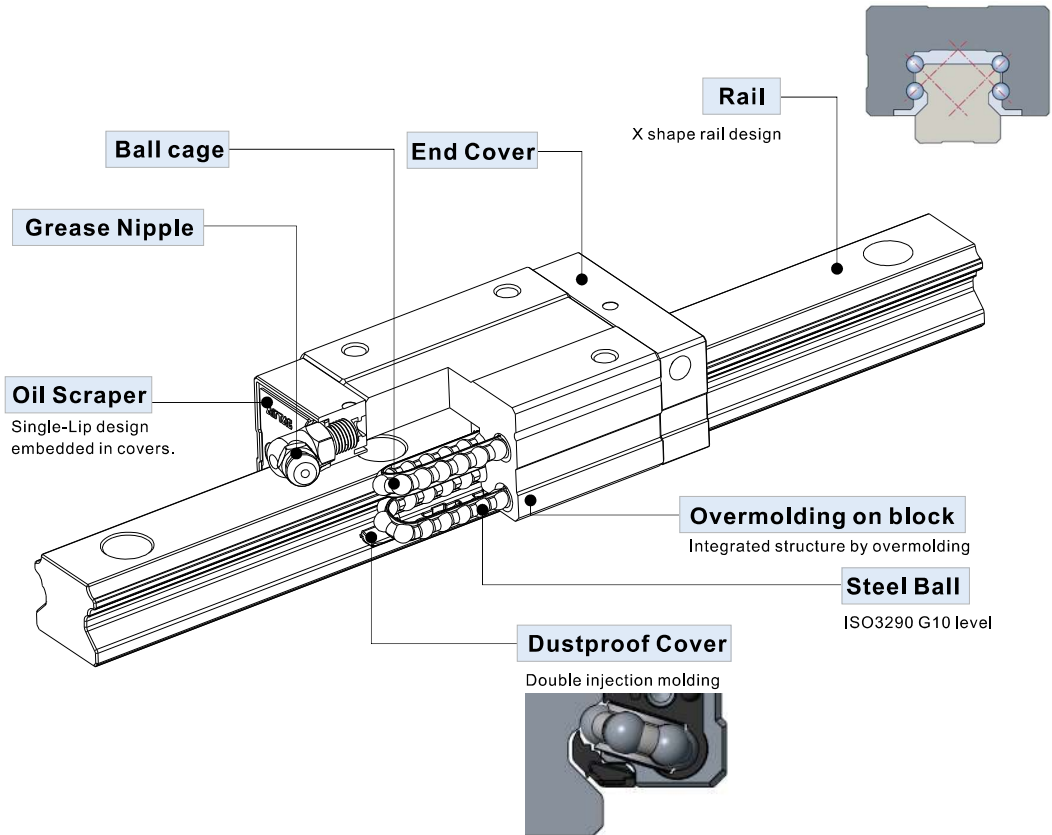

Product Features

1. Low noise design

The use of a special ball cage makes balls aligned precisely in a certain even distance, thus to eliminate noise made by random friction between balls, especially effective on high pitch noise. (details see Pic.1). According to study, human body is most sensitive to the sound between 1,000 and 3,000 Hz. After thorough lab test within allowable speed range, LSQH series can reduce noise degree by 5 dB(A) compared with LSH series. (details see Pic.2)

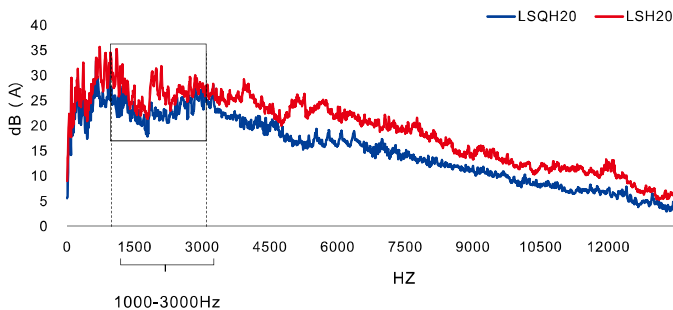

Pic.1 - Noise frequency comparison test between LSQH series and LSH series.

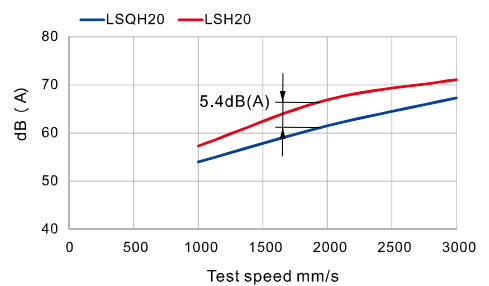

Pic.2 - Noise degree comparison test between LSQH series and LSH series.





LSQH Series Caged Ball Type Linear Guide

2. Self-lubricating design

Maintain designated grease storage zones at specific intervals in ball cage, precisely meeting the lubrication needs of the balls. When the circulation system operates to the direction reversal area, lubricant is automatically and evenly refilled, reducing the frequency and workload of manual grease refilling.

general ultra-light loads, no additional maintenance is required, lowering the total maintenance cost.

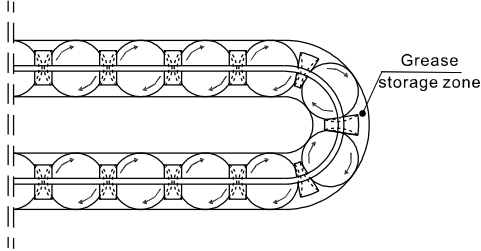

Test model	LSQH20HN1X2000S20AH-M6	Lifespan test
Speed	1 m/s	
Lubricant	Only add grease at the beginning of test (No grease supply in the middle of experiment)	
Load	4.7 KN	
Stroke	1200 KM	

3. High-velocity design

The spacer design of the ball cage eliminates friction between balls. With the balls and ball cage forming an annular line contact, friction is significantly reduced. During high-speed operation, energy loss is minimized, and heat generation is controlled, enabling the linear guide to achieve exceptional high-speed performance. This provides precise and stable linear motion guidance for high-speed mechanical systems, expanding applications in high-speed automation production lines and related fields.

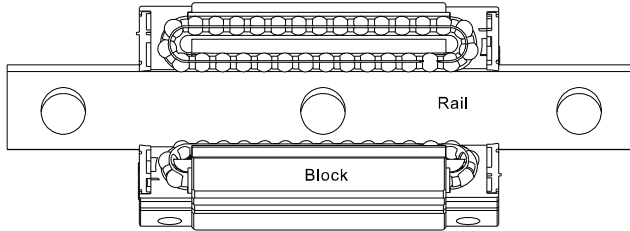

4. Improve smoothness

In traditional linear guide which is without ball cage, balls experience back-and-forth collisions during initial operation, causing severe fluctuations in friction and poor stability. The ball cage can link the balls together, allowing them to start moving almost simultaneously along with block movement, eliminating back-and-forth collisions. This maintains stable motion inertia, reduces variations in friction, ensures smooth and stable movement, and enhances fluidity and stability metrics, providing reliable support for high-precision motion control.

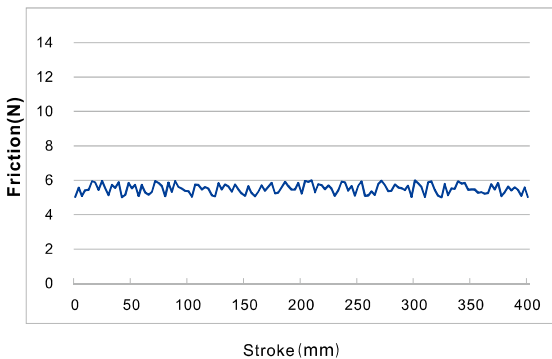

LSQH20 caged ball type(light preload) linear guide friction variation curve

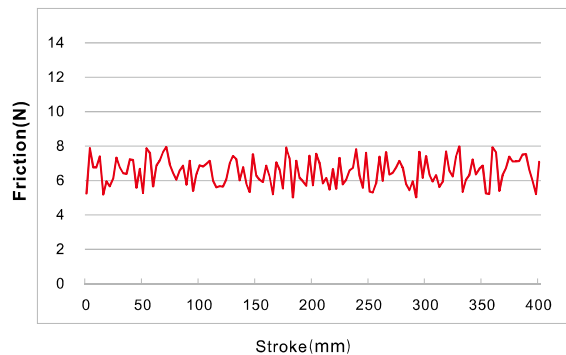

LSH20 standard type(light preload) linear guide friction variation curve



Caged Ball Type Linear Guide

LSQH Series

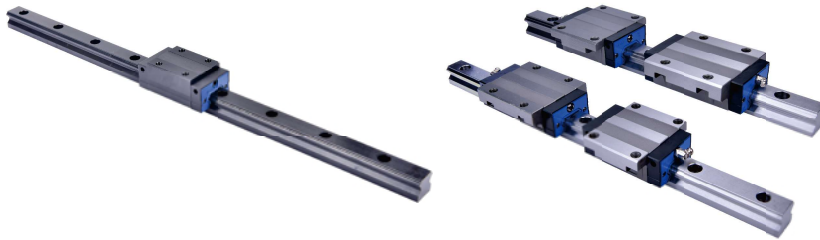

Order Information(Combined)

LSQH □ 20 H N 1 X220 S20 A H - AM8 - B - T

① ② ③ ④ ⑤ ⑥ ⑦ ⑧ ⑨ ⑩ ⑪ ⑫ ⑬

① Model Code	LSQH:Caged Ball Type Linear Guide				
② Rail&Block surface treatment	Blank: without additional coating. (natural color) ★BB: Block and rail coated with black chrome				
③ Rail Width	15: 15mm 20: 20mm 25: 23mm 30: 28mm 35: 34mm				
④ Block Style	H: Square type F1: Flange type, Mounting from top F2: Flange type, Mounting from bottom F3: Flange type, Mounting from top or bottom				
⑤ Block type	N: Standard L: Long [w/o 15 series]				
⑥ Number of Block	1: One 2: Two [Note: Amount of block on a single set of linear guide]				
⑦ Length of Rail	220:220mm[Defined by customer]				
⑧ Position of first mounting hole	S□ : Distance from end of rail to the center of first mounting hole (It is recommended to be greater than minimum margin)				
⑨ Preload	A: Standard clearance B: Light Preload C: Medium Preload D: Heavy Preload				
⑩ Accuracy	N : Normal H : High P : Precision				
⑪ Nipple /adapter type	M4: M4 Nipple		M6: M6 Nipple		
	AM6: M4 to M6	I type	20 25 30 35	A01: M6 to PT1/8	I type
		L type		AM8: M6 to M8	
	LM6: M4 to M6		L01: M6 to PT1/8	L type	
			LM8: M6 to M8		
			SM6: M6 Nipple		
⑫ Packing type	Blank: the block and rail are assembled B: block and rail are put separately				
⑬ Rail type	Blank: Top-mount T: Bottom-mount				

- ★ [Note 1] Self-lubricator standard type please refer to Pg. 81. for more detail.
- [Note 2] Heavy preload is available for LSQH25/30/35 only.
- [Note 3] LSQH15 only Square(H) and Flange mounting from top(F1) block styles are available.
- [Note 4] For LSQH-BB series, standard length of a rail is 3 m.
Please contact with our company if length of rail exceeds the maximum.

Caged Ball Type Linear Guide

LSQH Series

Butt-jointed Order Information

LSQH □ 20 H N 1X2970 T 2940 T 2970 A H – AM8-B – T

① ② ③ ④ ⑤ ⑥ ⑦ ⑧ ⑨ ⑩ ⑪ ⑫ ⑬ ⑭ ⑮ ⑯

Butt-jointed end margin: 1/2P
Position of the first and last hole is defined by customer.

① Model Code	LSQH:Caged Ball Type Linear Guide					
② Rail&Block surface treatment	Blank: without additional coating. (natural color) ★BB: Block and rail coated with black chrome					
③ Rail Width	15: 15mm 20: 20mm 25: 23mm 30: 28mm 35: 34mm					
④ Block Style	H: Square type F1: Flange type, Mounting from top F2: Flange type, Mounting from bottom F3: Flange type, Mounting from top or bottom					
⑤ Block type	N: Standard L: Long [w/o 15 series]					
⑥ Number of Block	1: One 2: Two [Note: Amount of block on a single set of linear guide]					
⑦ Length of first Rail	2970:2970mm[Defined by customer]					
⑧ Butt-jointed mark	T: Rail Butt-jointed mark (Butt-jointed end margin: 1/2P) [P is the standard hole distance]					
⑨ Length of second Rail	2940:2940mm[Defined by customer]					
⑩ Butt-jointed mark	Blank: two rails joint T: Rail Butt-jointed mark (Butt-jointed end margin: 1/2P) [P is the standard hole distance]					
⑪ Length of third Rail	Blank: two rails joint 2970:2970mm.....[Defined by customer]					
⑫ Preload	A: Standard clearance B: Light Preload C: Medium Preload D: Heavy Preload					
⑬ Accuracy	N: Normal H: High					
⑭ Nipple /adapter type	15	M4: M4 Nipple		M6: M6 Nipple		
		AM6: M4 to M6	I type 	A01: M6 to PT1/8	I type 	
		LM6: M4 to M6	L type 	20	AM8: M6 to M8	
				25	L01: M6 to PT1/8	L type
30	LM8: M6 to M8		SM6: M6 Nipple			
35						
⑮ Packing type	Blank: the block and rail are assembled B: block and rail are put separately					
⑯ Rail type	Blank: Top-mount T: Bottom-mount					

★[Note1] Self-lubricator standard type please refer to Pg. 81. for more detail.

[Note2] Number of joints cannot be more than 2 times(three rails at most).

For LSQH15/20/25, maximum length of jointed rail is 11800mm.

For LSQH30/35, it's 11880. Customization is needed for joint times more than standard.

[Note3] Heavy preload is available for LSQH25/30/35 only.

[Note4] LSQH15 only Square(H) and Flange mounting from top(F1) block styles are available.

[Note5] For LSQH-BB series, standard length of a rail is 3 m.

Maximum length of two-joint rail is 6 m.

Maximum length of three-joint rail is 9 m.

Please contact with our company

if length of rail exceeds the maximum.

Caged Ball Type Linear Guide

LSQH Series

1. Block Order Information

LSQH □ 20 BK-H N-H-D-AM8

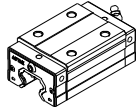

N: Standard

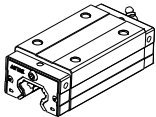

L: Long

① Model Code	LSQH:Caged Ball Type Linear Guide					
② Coating on block	Blank: Block without additional coating. (natural color) ★B: Block coated with black chrome					
③ Rail Width	15: 15mm 20: 20mm 25: 23mm 30: 28mm 35: 34mm					
④ Block Code	BK: Block					
⑤ Block Style	H: Square type F1: Flange type, Mounting from top F2: Flange type, Mounting from bottom F3: Flange type, Mounting from top or bottom					
⑥ Block type	N: Standard L: Long [w/o 15 series]					
⑦ Accuracy	N: Normal H: High					
⑧ Group code	SA SB SC SE SF B C D [Add]					
⑨ Nipple /adapter type	15	M4: M4 Nipple		M6:M6 Nipple		
		AM6: M4 to M6	I type		A01:M6 to PT1/8	I type
			L type		AM8:M6 to M8	
		LM6: M4 to M6	L type		L01:M6 to PT1/8	L type
					LM8:M6 to M8	
SM6:M6 Nipple						

★ [Note 1] Self-lubricator standard type please refer to Pg. 81. for more detail.

[Note 2] LSQH15 only Square(H) and Flange mounting from top(F1) block styles are available.

Add: When selecting rails and bearings, the different pairing codes can change the units preload. details see "preload pairing chart".

2. Rail(4m) Order Information

LSH 15 RL X 4000-H - E - T

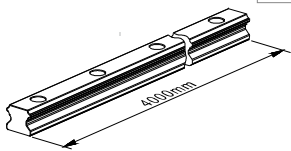

① Model Code	LSH:Standard Type Linear Guide			
② Rail Width	15: 15mm 20: 20mm 25: 23mm 30: 28mm 35: 34mm			
③ Rail Code	RL: Rail			
④ Rail Length	4000 : 4000mm			
⑤ Accuracy	N : Normal H : High			
⑥ Group code	E [Note]			
⑦ Rail type	Blank: Top-mount T: Bottom-mount			

Note: ●Standard length of LSH rail is four meters.

●For LSH15/20/25, both margin pitch of rail are 20mm.

●For LSH30/35, one side of margin pitch is 20mm, the other side is 60mm.

●When selecting rails and bearings, the different pairing codes can change the units preload. details see "preload pairing chart".

3. Rail Order Information

LSH □ 15 RL X 220-S20 - H - E - T

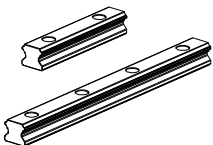

① Model Code	LSH:Standard Type Linear Guide			
② Coating on rail	Blank: Rail without additional coating. (natural color) ★B: Rail coated with black chrome			
③ Rail Width	15: 15mm 20: 20mm 25: 23mm 30: 28mm 35: 34mm			
④ Rail Code	RL: Rail			
⑤ Rail Length	220:220mm[Defined by the customer]			
⑥ Position of first mounting hole	S□ : Distance from end of rail to the center of first mounting hole (It is recommended to be greater than minimum margin)			
⑦ Accuracy	N : Normal H : High			
⑧ Group code	E [Note]			
⑨ Rail type	Blank: Top-mount T: Bottom-mount			

Note: 1. When selecting rails and bearings, the different pairing codes can change the units preload. details see "preload pairing chart".

2. For LSH-B series, standard length of a rail is 3 m.

LSQH Series

4. Rail/Block preload pairing chart

When customer orders rail/block, please choose the pairing code of rail/block in accordance with the needed preload of linear guide(combined). Details please refer to the "preload pairing chart".

Model	Rail pairing code	Block pairing code	Preload grade	Model	Rail pairing code	Block pairing code	Preload grade
LSQH15 LSQH20	E	D	Standard clearance	LSQH25	E	D	Standard clearance
		C	Light preload			C	Light preload
		SA	Medium preload			SB	Medium preload
		SE	Heavy Preload				
Model	Rail pairing code	Block pairing code	Preload grade	Model	Rail pairing code	Block pairing code	Preload grade
LSQH30	E	D	Standard clearance	LSQH35	E	D	Standard clearance
		C	Light preload			B	Light preload
		SC	Medium preload			SC	Medium preload
		SF	Heavy Preload			SF	Heavy Preload

Accessory Order Code

L - P - AM6

① ② ③

① Accessory Code	L: Linear Guide Accessory		
② Nipple/adaptor Code	P: Nipple/adaptor		
③ Nipple/adaptor type	M4: M4 Nipple	Nipple M6: M6 Nipple	
	AM6: M4 to M6	I type SM6: M6 Nipple	
	LM6: M4 to M6	L type	A01: M6 to PT1/8
			AM8: M6 to M8
		L01: M6 to PT1/8	
		LM8: M6 to M8	

Rail (4m) Specification

1. The maximum length of a single rail is 4,000 mm, please refer to the table for more detail about edge pitch of first mounting hole (S) and last mounting hole (E).

2. The edge pitch of first mounting hole (S) and last mounting hole (E) should not be greater than 1/2P. Overlong edge may induce unstable installation and affect the accuracy.

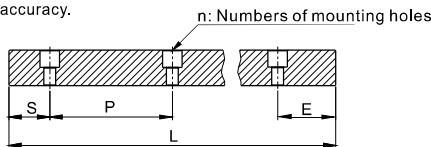

$$L = (n-1) \times P + S + E$$

L: Total length of rail(mm)

n: Numbers of mounting holes on rail

P: Distance between bolt holes(mm)

S: Edge of first mounting hole(mm)

E: Edge of last mounting hole(mm)

Model	LSH15	LSH20	LSH25	LSH30	LSH35
Pitch(P)	60	60	60	80	80
Rail (4m) Standard Edge Pitch(S)	20	20	20	20	20
Rail (4m) Standard Edge Pitch(E)	20	20	20	60	60
Min. Edge Pitch(S/E min)	5	6	7	8	8
Max. Edge Pitch(S/E max)	55	54	53	72	72
Maximum length(Lmax)	4000	4000	4000	4000	4000

Note:

- Joint rail must be chosen if length of rail exceeds the maximum.
- When deciding edge pitch, it should be within the range of above table. There would be risk of broken hole if pitch is out of range.
- Maximum length of rail for standard' means the maximum length of rail can be chosen when both sides of edge pitches are standard.

Caged Ball Type Linear Guide

LSQH Series

Specifications and Dimensions

Square type

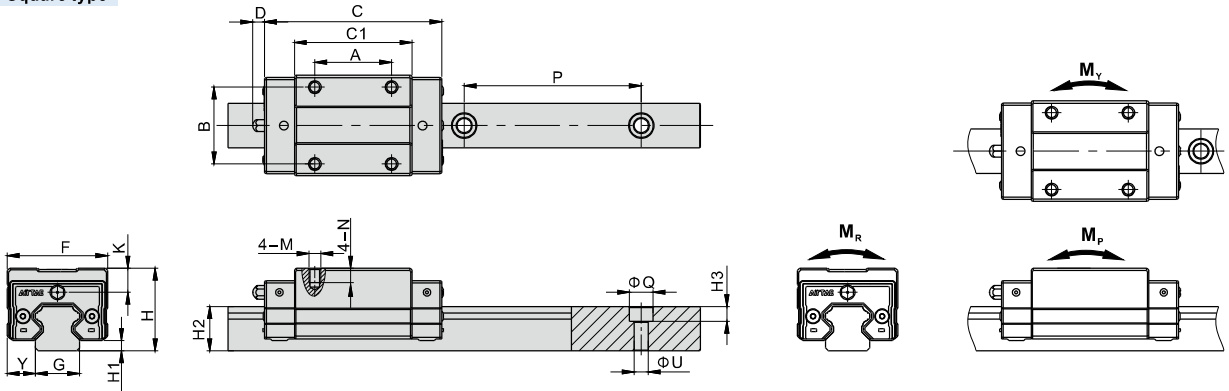

Model/Item	External Dimension (mm)					Block Dimension (mm)						Rail Dimension (mm)						
	H	H1	F	Y	C	C1	A	B	K	D	M	N	G	H2	P	ϕQ	ϕU	H3
LSQH15HN	28	3.5	34	9.5	61.5	41.5	26	26	8.3	6	M4X0.7	5	15	15	60	8	4.8	5.3
LSQH20HN	30	4.5	44	12	77	54.5	36	32	6.5	12.5	M5X0.8	5	20	17.5	60	9.5	5.8	8.5
LSQH20HL	30	4.5	44	12	92	69.5	50	32	6.5	12.5	M5X0.8	5	20	17.5	60	9.5	5.8	8.5
LSQH25HN	40	6.5	48	12.5	83.5	60	35	35	10.9	12.5	M6X1.0	8	23	22	60	11.2	7	9
LSQH25HL	40	6.5	48	12.5	104.5	81	50	35	10.9	12.5	M6X1.0	8	23	22	60	11.2	7	9
LSQH30HN	45	6.5	60	16	97.5	73	40	40	11	13	M8X1.25	10	28	26	80	14.2	9	12
LSQH30HL	45	6.5	60	16	122	97	60	40	11	13	M8X1.25	10	28	26	80	14.2	9	12
LSQH35HN	55	7	70	18	113	82	50	50	16.2	12.5	M8X1.25	12	34	29	80	14.2	9	12
LSQH35HL	55	7	70	18	140.5	109.5	72	50	16.2	12.5	M8X1.25	12	34	29	80	14.2	9	12

Model/Item	Mounting Screw	Dynamic Load Rating(kN)	Static Load Rating(kN)	Static Rated Moment (kN.m)			Weight	
		C	C ₀	M _r	M _p	M _v	Block(kg)	Rail(kg/m)
LSQH15HN	M4	13.8	14.9	0.10	0.10	0.10	0.2	1.43
LSQH20HN	M5	24.2	27.5	0.26	0.24	0.24	0.33	2.23
LSQH20HL	M5	28.9	36.4	0.34	0.33	0.33	0.41	2.23
LSQH25HN	M6	29.9	37.6	0.42	0.35	0.35	0.54	3.32
LSQH25HL	M6	36.6	47.5	0.52	0.51	0.51	0.70	3.32
LSQH30HN	M8	42.8	55.0	0.66	0.67	0.67	0.91	4.5
LSQH30HL	M8	52.3	70.0	0.84	0.87	0.87	1.17	4.5
LSQH35HN	M8	56.3	72.3	1.05	0.92	0.92	1.51	6.37
LSQH35HL	M8	58.6	92.6	1.47	1.40	1.40	1.93	6.37

Caged Ball Type Linear Guide

LSQH Series

Flange type, Top-Mount

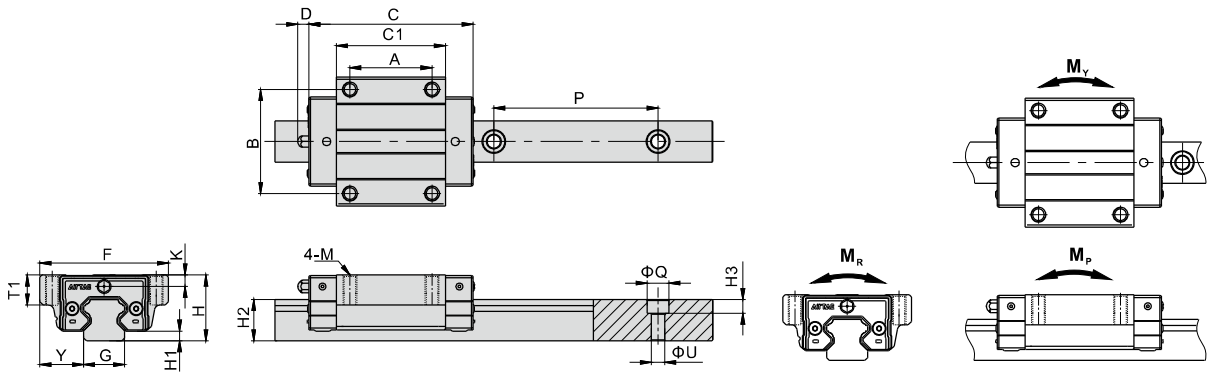

Model/Item	External Dimension (mm)				Block Dimension (mm)								Rail Dimension (mm)					
	H	H1	F	Y	C	C1	A	B	K	D	M	T1	G	H2	P	ΦQ	ΦU	H3
LSQH15F1N	24	3.5	47	16	61.5	41.5	30	38	4.3	6	M5X0.8	11	15	15	60	8	4.8	5.3
LSQH20F1N	30	4.5	63	21.5	77	54.5	40	53	6.5	12.5	M6X1.0	10	20	17.5	60	9.5	5.8	8.5
LSQH20F1L	30	4.5	63	21.5	92	69.5	40	53	6.5	12.5	M6X1.0	10	20	17.5	60	9.5	5.8	8.5
LSQH25F1N	36	6.5	70	23.5	83.5	60	45	57	6.9	12.5	M8X1.25	16	23	22	60	11.2	7	9
LSQH25F1L	36	6.5	70	23.5	104.5	81	45	57	6.9	12.5	M8X1.25	16	23	22	60	11.2	7	9
LSQH30F1N	42	6.5	90	31	97.5	73	52	72	8	13	M10X1.5	18	28	26	80	14.2	9	12
LSQH30F1L	42	6.5	90	31	122	97	52	72	8	13	M10X1.5	18	28	26	80	14.2	9	12
LSQH35F1N	48	7	100	33	113	82	62	82	9.2	12.5	M10X1.5	21	34	29	80	14.2	9	12
LSQH35F1L	48	7	100	33	140.5	109.5	62	82	9.2	12.5	M10X1.5	21	34	29	80	14.2	9	12

Model/Item	Mounting Screw	Dynamic Load Rating(kN)	Static Load Rating(kN)	Static Rated Moment (kN.m)			Weight	
				MR	MP	MV	Block(kg)	Rail(kg/m)
LSQH15F1N	M4	C	C ₀	0.10	0.10	0.10	0.20	1.43
LSQH20F1N	M5	13.8	14.9	0.26	0.24	0.24	0.40	2.23
LSQH20F1L	M5	24.2	27.5	0.34	0.33	0.33	0.80	2.23
LSQH25F1N	M6	28.9	36.4	0.42	0.35	0.35	0.60	3.32
LSQH25F1L	M6	29.9	37.6	0.52	0.51	0.51	0.86	3.32
LSQH30F1N	M8	36.6	47.5	0.66	0.67	0.67	1.09	4.5
LSQH30F1L	M8	42.8	55.0	0.84	0.87	0.87	1.38	4.5
LSQH35F1N	M8	52.3	70.0	1.05	0.92	0.92	1.57	6.37
LSQH35F1L	M8	56.3	72.3	1.47	1.40	1.40	2.05	6.37

Caged Ball Type Linear Guide

LSQH Series

Flange type, Bottom-Mount

Flange type, Top or Bottom-Mount

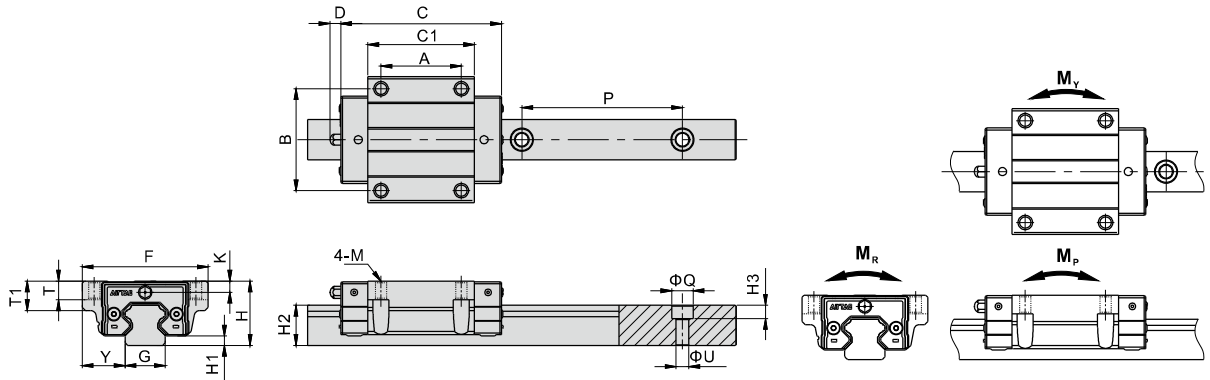

Model/Item	External Dimension (mm)					Block Dimension (mm)							Rail Dimension (mm)							
	H	H1	F	Y	C	C1	A	B	K	D	M		T	T1	G	H2	P	ΦQ	ΦU	H3
											Bottom-Mount	Top or Bottom-Mount								
LSQH20F2(F3)N	30	4.5	63	21.5	77	54.5	40	53	6.5	12.5	Φ5.7	M6X1.0	9.5	10	20	17.5	60	9.5	5.8	8.5
LSQH20F2(F3)L	30	4.5	63	21.5	92	69.5	40	53	6.5	12.5	Φ5.7	M6X1.0	9.5	10	20	17.5	60	9.5	5.8	8.5
LSQH25F2(F3)N	36	6.5	70	23.5	83.5	60	45	57	6.9	12.5	Φ6.8	M8X1.25	10	16	23	22	60	11.2	7	9
LSQH25F2(F3)L	36	6.5	70	23.5	104.5	81	45	57	6.9	12.5	Φ6.8	M8X1.25	10	16	23	22	60	11.2	7	9
LSQH30F2(F3)N	42	6.5	90	31	97.5	73	52	72	8	13	Φ9	M10X1.5	10	18	28	26	80	14.2	9	12
LSQH30F2(F3)L	42	6.5	90	31	122	97	52	72	8	13	Φ9	M10X1.5	10	18	28	26	80	14.2	9	12
LSQH35F2(F3)N	48	7	100	33	113	82	62	82	9.2	12.5	Φ9	M10X1.5	13	21	34	29	80	14.2	9	12
LSQH35F2(F3)L	48	7	100	33	140.5	109.5	62	82	9.2	12.5	Φ9	M10X1.5	13	21	34	29	80	14.2	9	12

Model/Item	Mounting Screw	Dynamic Load Rating (kN)	Static Load Rating (kN)	Static Rated Moment (kN.m)			Weight	
		C	C ₀	M _R	M _p	M _y	Block (kg)	Rail (kg/m)
LSQH20F2(F3)N	M5	24.2	27.6	0.26	0.24	0.24	0.40	2.23
LSQH20F2(F3)L	M5	28.9	36.4	0.34	0.33	0.33	0.80	2.23
LSQH25F2(F3)N	M6	29.9	37.6	0.42	0.35	0.35	0.60	3.32
LSQH25F2(F3)L	M6	36.6	47.5	0.52	0.51	0.51	0.86	3.32
LSQH30F2(F3)N	M8	42.8	55.0	0.66	0.67	0.67	1.09	4.5
LSQH30F2(F3)L	M8	52.3	70.0	0.84	0.87	0.87	1.38	4.5
LSQH35F2(F3)N	M8	56.3	72.3	1.05	0.92	0.92	1.57	6.37
LSQH35F2(F3)L	M8	58.6	92.6	1.47	1.40	1.40	2.05	6.37

Dimension of bottom-mount type rail

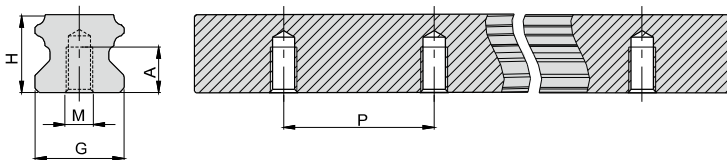

Model/Item	G	H	M	A	P
LSQH15T	15	15	M5X0.8	8	60
LSQH20T	20	17.5	M6X1.0	10	60
LSQH25T	23	22	M6X1.0	12	60
LSQH30T	28	26	M8X1.25	15	80
LSQH35T	34	29	M8X1.25	17	80

LSQH Series

Accuracy

LSQH standard type linear guide comes with 3 accuracy levels.

	Accuracy Standards (mm)						
	Accuracy Model	N : Normal		H: High		P: Precision	
		15/20	25/30/35	15/20	25/30/35	15/20	25/30/35
Tolerance of height H	±0.1		±0.03	±0.04	±0.015	±0.02	
Variation of height ΔH	0.02	0.025	0.01	0.015	0.006	0.007	
Tolerance of width Y	±0.1		±0.03	±0.04	±0.015	±0.02	
Variation of width ΔY	0.02	0.03	0.01	0.015	0.006	0.007	
Parallelism of C-surface relative to A-surface	Parallelism of raceway (Refer to Table 1)						
Parallelism of D-surface relative to B-surface	Parallelism of raceway (Refer to Table 1)						

Table 1 : Parallelism of the raceway

Rail Length(mm) Accuracy	100 under	100~200	200~300	300~500	500~700	700~900	900~1100	1100~1500	1500~1900	1900~2500	2500~3100	3100~3600	3600~4000
	Parallelism of the raceway(μm)												
N	12	14	15	17	20	22	24	26	28	31	33	36	37
H	7	9	10	12	13	15	16	18	20	22	25	27	28
P	3	4	5	6	7	8	9	11	13	15	18	20	21

Preload Level

1. Preload interference

The LSQH standard type Linear Guide has three preload categories: A, B and C.

Choosing suitable preload level will enhance rigidity, precision and torsion resistant performance of the linear guide.

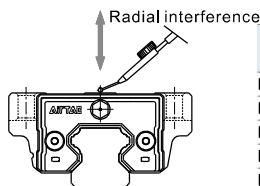

Model	Radial interference(μm)			
	Standard clearance(A)	Light Preload(B)	Medium Preload(C)	Heavy Preload(D)
LSQH15	-7~-1	-12~-4	-22~-14	-
LSQH20	-8~-1	-13~-5	-23~-15	-
LSQH25	-9~-1	-14~-6	-24~-16	-33~-25
LSQH30	-10~-1	-16~-7	-29~-20	-38~-29
LSQH35	-11~-1	-21~-11	-34~-24	-43~-33

2. Common Application

Refer to following table for suitable application of different preload grade:

Preload grade	Requirement	Common Application
Standard clearance(A)	One axial movement, small vibration and impact, accuracy requirement is low	Conveyor Machine, Semiconductor Equipment, Stage Equipment, Press Machine, Welding Machine and other light movement equipments
Light Preload(B)	Equipment that requires light-load and high-precision.	Z-axis movement for industrial use, NC lathe, EDM, Precision XY platform, Vertical machine center, measurement instrument, material feeder or industrial robot
Medium Preload(C)	Equipment that requires high rigidity, large vibration and shock.	Machining centers, NC lathes, grinders, vertical or horizontal milling machines, boring machines, tool guides, heavy cutting machines.
Heavy Preload(D)	Equipment that requires higher rigidity, larger vibration and shock.	Machining centers, NC lathes, grinders, vertical or horizontal milling machines, boring machines, tool guides, heavy cutting machines.

LSQH Series

Installation Illustration

1. Allowable tolerance of mounting surface

LSQH series is an arc-shape, two-point contact design of linear guide. Its self-centering feature allows some tolerance on mounting surface without affecting the smoothness of linear motion. The allowable tolerance is indicated in following table:

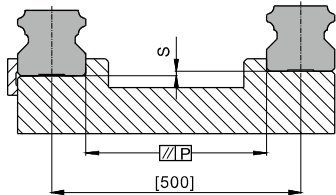

Model	Allowable tolerance of parallelism P(μm)			Allowable tolerance of top and bottom S (μm)		
	Standard clearance(A)	Light Preload(B)	Medium Preload(C)	Standard clearance(A)	Light Preload(B)	Medium Preload(C)
LSQH15	25	18	13	130	85	35
LSQH20	25	20	18	130	85	50
LSQH25	30	22	20	130	85	70
LSQH30	40	30	27	170	110	90
LSQH35	50	35	30	210	150	120

Note: The value in the table is the allowable value when the distance between the two linear guides is 500mm, and the allowable value is proportional to the distance between the two linear guides.

2. Height and Chamfer of Reference Edge

In order to ensure accurate installation of LSQH Linear Guide, the contact space should not exceed the given figures in following table.

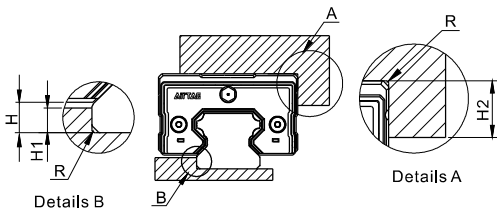

Unit : mm

Model	H	H1	H2	R(Max)
LSQH15	3.5	3	4	0.5
LSQH20	4.5	3.7	5	0.5
LSQH25	6.5	5	5	1
LSQH30	6.5	5	5	1
LSQH35	7	6	6	1

3. Screw Tighten Torque

When installing linear guide, whether the screws are well tighten and surface is well contacted will affect accuracy significantly. Please refer to following table for tightening force to ensure a perfect installation.

Model	Screw size	Tighten Torque(N.cm)		
		Iron	Casting	Aluminum alloy
LSQH15	M4	412	274	206
LSQH20	M5	882	588	441
LSQH25	M6	1370	921	686
LSQH30	M8	3040	2010	1470
LSQH35	M8	3040	2010	1470

4. Installation and Application

Linear guide installation methods can be divided into the followings.

For installations other than forward installation, the lubricant may fail.

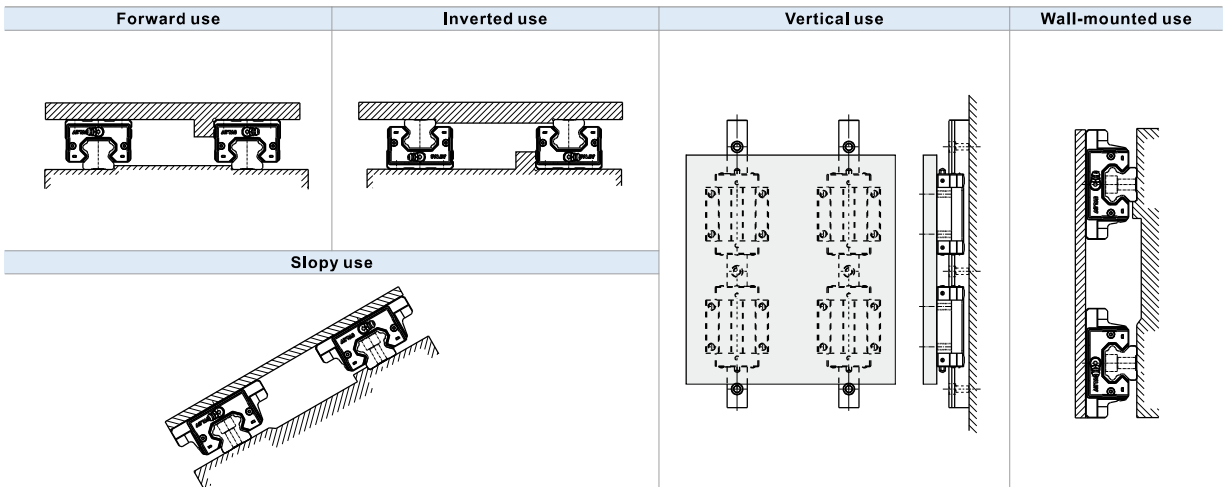

LSQH Series

5. Datum plane

- Datum plane for installation must be ground or finely milled to ensure accuracy.
- Both sides of Rail can be used as the datum plane.
- For multi-blocks on a rail, identification line on blocks should be put on the same side to ensure moving accuracy.

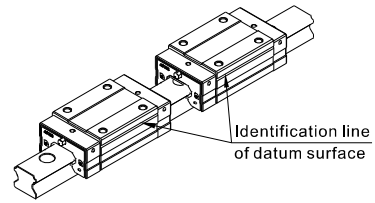

6. Fixation Method

Rails and blocks are possible to be displaced while the machine is subjected to vibrations and impacts thus to affect the accuracy. In order to avoid those difficulties and achieve high running accuracy, the following four methods are recommended for fixing.

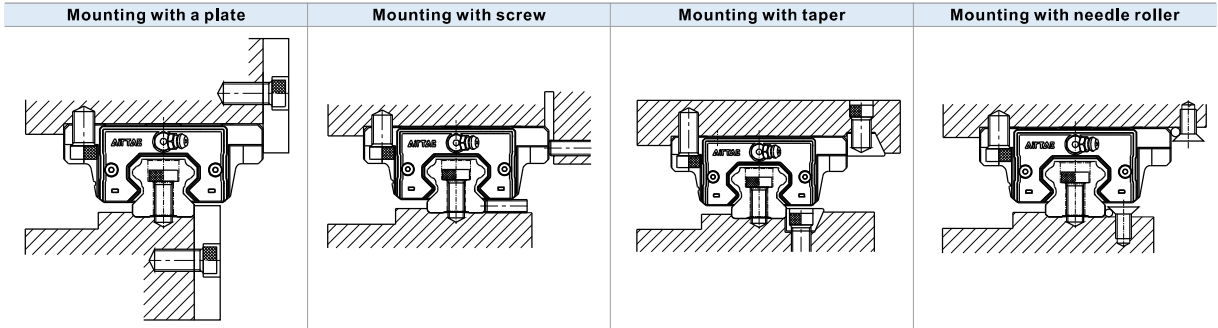

7. Rail Installation

A. Before installing the rail, remove all dirt from the mounting surface with oil stone, and then wipe with a clean cloth.

Remove all dirt from the mounting surface with oil stone, and then wipe with a clean cloth

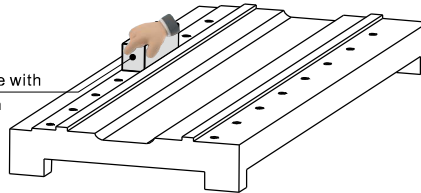

B. Place the rail gently on the bed firstly, then put the bolts into the mounting holes and pre-tighten them, place the rail ① into close contact with the datum plane of the bed by using the baffle, tighten the bolts with appropriate torque to fix the rail. Refer to "3. Screw tighten torque" for recommended torque value.

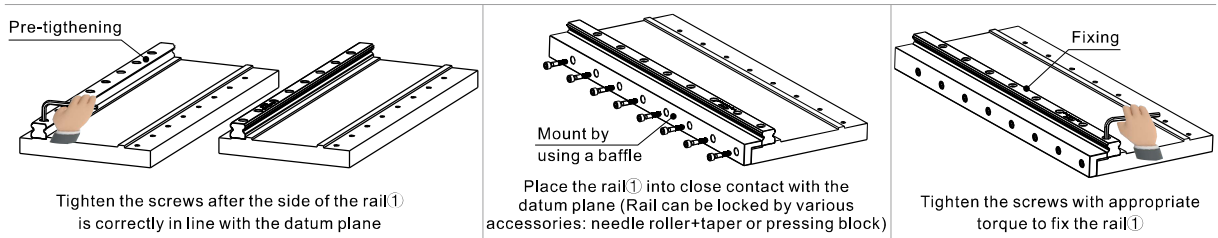

8. Block Installation

- Temporarily fix the table on the block by using the mounting bolts.
- Push the block datum plane against the side datum plane of the table and position the block by tightening the set screws.
- Tighten the mounting bolts in 1 to 4 sequences to fix the table on the block.

9. Subsidiary Rail Installation

Under the condition that the subsidiary rail has a reference datum plane, remove all dirt from the mounting surface with oil stone, and then wipe with a clean cloth, mount the subsidiary rail ② with the same method of the master rail ①.

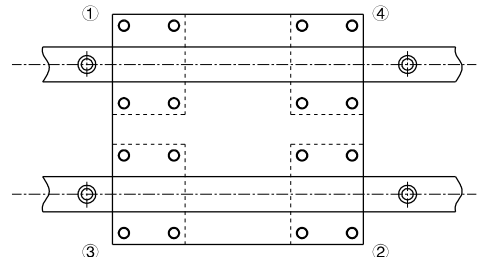
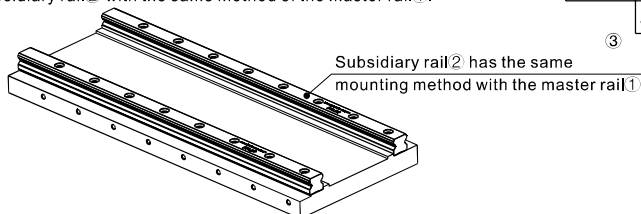

Under the condition that the subsidiary rail ② has a reference datum plane, remove all dirt from the mounting surface with oil stone, and then wipe with a clean cloth,

LSQH Series

10. Rail Installation without Side Datum Surface

Using a provisional datum plane

Use the datum plane provided on the bed for straight alignment of the rail from one end to the other, attention must be paid to fix two blocks in close contact on the measuring plate.

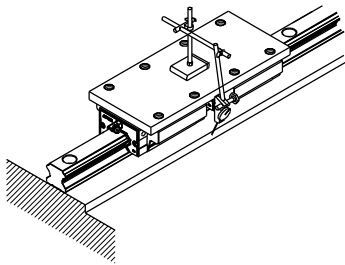

Using a straight-edge

Put the straight-edge between the two rails and use a dial gauge to adjust straight-edge in parallel with the side datum plane of the master rail. Use the dial gauge to ensure the straightness of the subsidiary rail by using the straight-edge as reference, then tighten the mounting bolts in proper sequence when the subsidiary rail is parallel to the master rail.

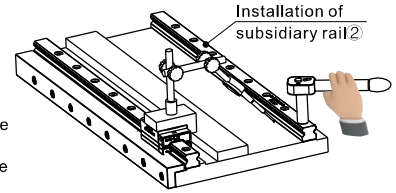

11. Rail Installation without Set Screws

To ensure parallelism between the subsidiary rail and the master rail in the condition without set screws, the following installation methods are recommended, and the installation of the block is the same as mentioned previously.

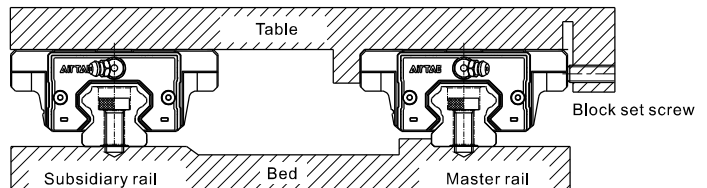

Installation of the master rail

Using a vice

Put the rail on the bed mounting surface and temporarily fasten the mounting bolts, then push the rail against the side datum plane of the bed by using a vice to ensure the rail position. Tighten the mounting bolts in proper sequence with specific torque.

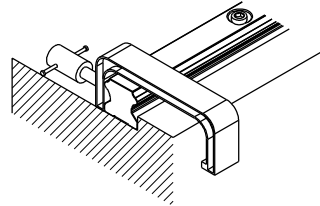

Installation of the subsidiary rail

Using a straight-edge

Put the straight-edge between the two rails and use a dial gauge to adjust straight-edge in parallel with the side datum plane of the master rail. Use the straight-edge to ensure the straightness of the subsidiary rail, then tighten the mounting bolts in proper sequence with specific torque.

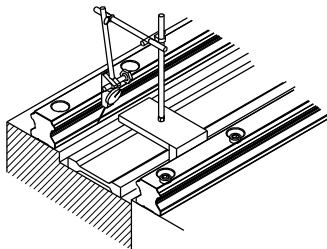

Using a table

Fix two blocks on the master rail to the table, and temporarily fix the subsidiary rail to the bed and one block on the subsidiary rail to the table. Place the gauge against the side surface of the block on the subsidiary rail, move the table from one end of the rail to the other end, then tighten the mounting bolts in proper sequence with specific torque while aligning the subsidiary rail parallel to the master rail.

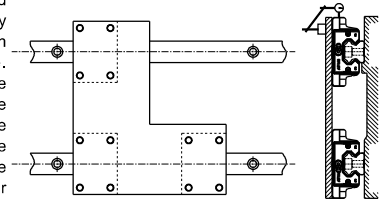

Following the master rail

Fix the table to the master rail and two blocks on the subsidiary rail, temporarily fix the other block on the subsidiary rail to the table and subsidiary rail to the bed. Moving the table from one end of the master rail and tighten the mounting bolts on the subsidiary rail in proper sequence with specific torque at the same time.

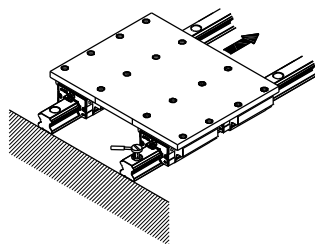

Using a jig

Use a special jig to help ensure the position of the subsidiary rail, and tighten the mounting bolts in proper sequence with specific torque.

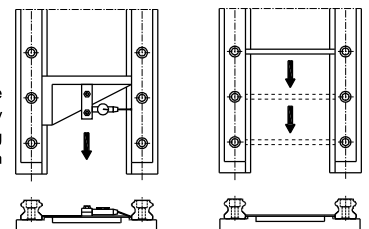

LSQH Series

12. Rail Butt-jointed

- When it comes to butt-jointed rail installation, it must follow the butt-jointed marks shown below.
- In order to avoid the accuracy caused by installing the matched jointed rails, it is recommended to stagger the butt-jointed positions, see figure below.

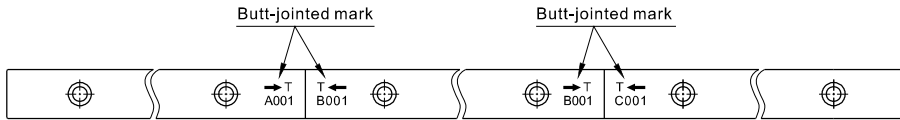

- When jointing rails, it must follow group marks on rail to ensure the accuracy of linear guide. These marks are located on the top surface at joint side. Please put the same group marks together.

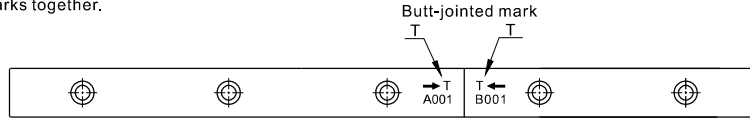

- Be aware serial number of group mark when assemble. A001 and B001 are in a group, so as to A002 and B002 and so on.
- Be aware the installation direction while assembly, the serial numbers are not upside down and arrows point to each other.

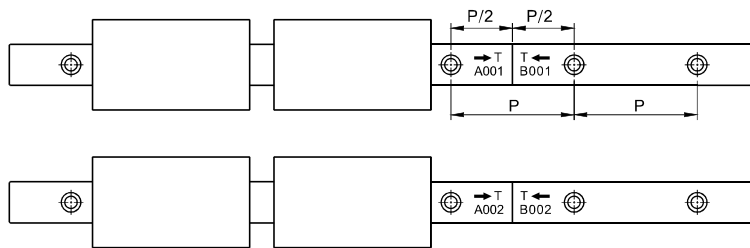

13. Measurement Method after Installation

When measuring running accuracy of the block, two blocks should be fixed on an inspection table in close contact to obtain stable accuracy.

When using a dial gauge, a provisional benchmark (like a straight-edge) is recommended to put as close as possible to the block for accurate measurement.

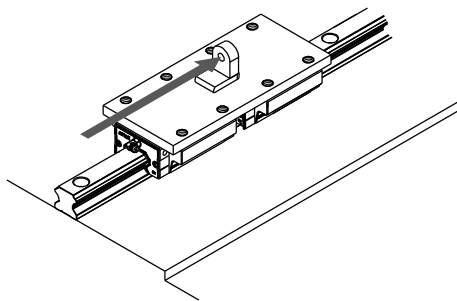

Method using an autocollimator

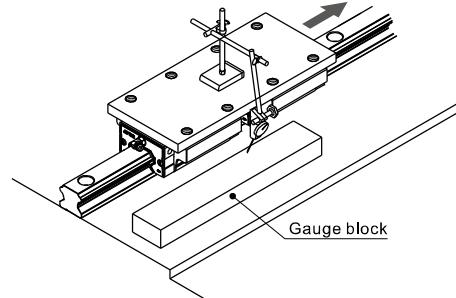

Method using a dial gauge

LSQH Series

Lubrication method

When a linear guide is well lubricated, it can reduce wear and increase lifespan significantly. Lubrication has the following benefits :

- Reduces friction of the rollers and raceway to minimize wear.
- The grease film between contact surface can prevent roller fatigue.
- Prevent rust.

1. Lubrication Grease

Use the correct grade of lubrication. While lubricating, a grease gun can be used to pump grease into slider through the grease nipple on it. The suitable condition for lube is when working speed is under 60 m/min and not in cooling process.

•Nipple type	L-P-M4	L-P-M6	L-P-SM6
Grease nipple type	LSQH15 	LSQH20 LSQH25 LSQH30 LSQH35 	LSQH20 LSQH25 LSQH30 LSQH35

•Grease amount

LSQH series linear guide is well lubricated with 'Shell Alvania grease S2' in factory. Customers are recommended to use identical or the same grade of lubricant. After lubrication, block needs to be moved back and forth at least three times for the length of three blocks and repeat at least twice. Check if the surface of rail is well covered by grease film.

Model	Grease amount for the first lubrication(cm ³)		Replenishment amount(cm ³)	
	Standard type	Long type	Standard type	Long type
LSQH15	0.9	-	0.3	-
LSQH20	1.8	2.7	0.6	0.9
LSQH25	3.6	4.5	1.1	1.4
LSQH30	5.4	7.2	1.7	2.2
LSQH35	8.1	10	2.5	3

•Lubrication frequency

Although the linear guides are well lubricated at the factory and retains grease well, frequent lubrication is still necessary to avoid undesirable wear. Recommended lubrication period is every 100km of movement or every 3~6 months. (Refer to table on the top for suggested amount)

2. Lubricating oil

Recommended oil viscosity for lubrication use is about 30 to 150 cst.

Lubrication oil is suitable for all kinds of load and impact application, but not for high temperature use due to its tendency of vaporization.

•Adaptor

L-P-AM6	L-P-AM8	L-P-A01
<p>LSQH15</p>	<p>LSQH35 LSQH30 LSQH25 LSQH20</p>	<p>LSQH35 LSQH30 LSQH25 LSQH20</p>
L-P-LM6	L-P-LM8	L-P-L01
<p>LSQH15</p>	<p>LSQH35 LSQH30 LSQH25 LSQH20</p>	<p>LSQH35 LSQH30 LSQH25 LSQH20</p>

LSQH Series

Lubrication method

•Oil supply rate

Loss of lubrication oil is faster than lubrication grease. Pay attention to sufficiency of oil while using.

Model	Oil amount for the first lubrication(cm ³)	Feeding Speed(cm ³ /hr)
LSQH15	0.6	0.2
LSQH20	0.6	0.2
LSQH25	0.9	0.3
LSQH30	0.9	0.3
LSQH35	0.9	0.3

3. Grease nipple/adaptor installation

- Grease nipple or adaptor can be installed in the two sides of block for manual or automatic lubrication based on customer's requirement.
- There are a secondary set of lubricating ports on the side of the block. When using, it is not recommended to use the side with datum line unless necessary.
- Lateral nipple installation is not recommended for flange type blocks. (The grease / oil nipple may interfere with block)
- If lateral lubrication is needed for above spec, please contact us for customization.

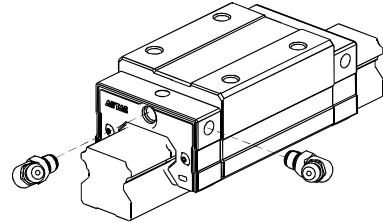

Bolt hole plug

1. Plug type

In order to prevent metal swarf or external objects from entering blocks and affecting precision and lifespan, customers must put plugs into holes during installation. Every rail is equipped with default plugs.

Model	Bolt	Diameter(D)(mm)	Thickness(H)(mm)
LSH15	M4	8.15	1.1
LSH20	M5	9.65	2.5
LSH25	M6	11.4	2.5
LSH30	M8	14.4	3.5
LSH35	M8	14.4	3.5

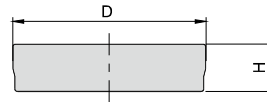

2. Plug installation Steps

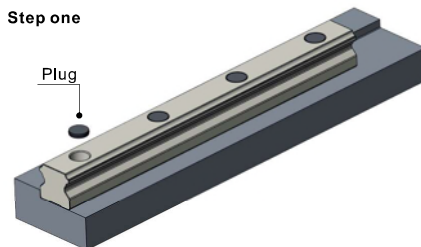

Place the plug in counterbore.

Note :

- Please make sure the plugs do not protrude the rail surface.
- After installation, please clean the surface before use.

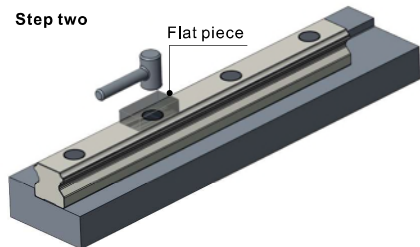

Place the flat piece on mounting hole, hit the piece vertically with a plastic hammer and fix the plug into counterbore.

Self-lubricator Standard Linear Guide

LSQH Series



Order Information(Combined)

LSQH □ 20 H N 1 X220 S20 A H - AM8 - B - T - E

① ② ③ ④ ⑤ ⑥ ⑦ ⑧ ⑨ ⑩ ⑪ ⑫ ⑬ ⑭

① Model Code	LSQH:Self-lubricator Standard Linear Guide		
② Rail&Block surface treatment	Blank: without additional coating. (natural color) ★BB: Block and rail coated with black chrome		
③ Rail Width	15: 15mm 20: 20mm 25: 23mm 30: 28mm 35: 34mm		
④ Block Style	H: Square type F1: Flange type, Mounting from top F2: Flange type, Mounting from bottom F3: Flange type, Mounting from top or bottom		
⑤ Block type	N: Standard L: Long [w/o 15 series]		
⑥ Number of Block	1: One 2: Two [Note: Amount of block on a single set of linear guide]		
⑦ Length of Rail	220:220mm[Defined by customer]		
⑧ Position of first mounting hole	S□ : Distance from end of rail to the center of first mounting hole (It is recommended to be greater than minimum margin)		
⑨ Preload	A: Standard clearance B: Light Preload C: Medium Preload D: Heavy Preload		
⑩ Accuracy	N : Normal H : High P : Precision		
⑪ Nipple /adapter type	15	M4: M4 Nipple I type	M6: M6 Nipple I type
		AM6: M4 to M6 L type	A01: M6 to PT1/8 AM8: M6 to M8 L01: M6 to PT1/8 L type
		LM6: M4 to M6	LM8: M6 to M8
			SM6: M6 Nipple
⑫ Packing type	Blank: the block and rail are assembled B: block and rail are put separately		
⑬ Rail type	Blank: Top-mount T: Bottom-mount		
⑭ Self-lubricator Standard Type	E: Self-lubricator Standard Type		

[Note 1] Heavy preload is available for LSQH25/30/35 only.

[Note 2] LSQH15 only Square(H) and Flange mounting from top(F1) block styles are available.

[Note 3] For LSQH-BB series, standard length of a rail is 3 m.

Please contact with our company if length of rail exceeds the maximum.

LSQH Series

Butt-jointed Order Information

LSQH □ 20 H N 1X2970T2940T2970 A H - AM8-B - T - E

① ② ③ ④ ⑤ ⑥ ⑦ ⑧ ⑨ ⑩ ⑪ ⑫ ⑬ ⑭ ⑮ ⑯ ⑰

Butt-jointed end margin: 1/2P .
Position of the first and last hole is defined by customer.

① Model Code	LSQH:Self-lubricator Standard Linear Guide	
② Rail&Block surface treatment	Blank: without additional coating. (natural color) ★BB: Block and rail coated with black chrome	
③ Rail Width	15: 15mm 20: 20mm 25: 23mm 30: 28mm 35: 34mm	
④ Block Style	H: Square type F1: Flange type, Mounting from top F2: Flange type, Mounting from bottom F3: Flange type, Mounting from top or bottom	
⑤ Block type	N: Standard L: Long [w/o 15 series]	
⑥ Number of Block	1: One 2: Two [Note: Amount of block on a single set of linear guide]	
⑦ Length of first Rail	2970:2970mm[Defined by customer]	
⑧ Butt-jointed mark	T: Rail Butt-jointed mark (Butt-jointed end margin: 1/2P) [P is the standard hole distance]	
⑨ Length of second Rail	2940:2940mm[Defined by customer]	
⑩ Butt-jointed mark	Blank: two rails joint T: Rail Butt-jointed mark (Butt-jointed end margin: 1/2P) [P is the standard hole distance]	
⑪ Length of third Rail	Blank: two rails joint 2970:2970mm.....[Defined by customer]	
⑫ Preload	A: Standard clearance B: Light Preload C: Medium Preload D: Heavy Preload	
⑬ Accuracy	N : Normal H : High	
⑭ Nipple /adapter type	M4: M4 Nipple	
	AM6: M4 to M6	
	LM6: M4 to M6	
	M6: M6 Nipple	
	I type	
	L type	
	A01: M6 to PT1/8	
	AM8: M6 to M8	
	L01: M6 to PT1/8	
	LM8: M6 to M8	
	SM6: M6 Nipple	
⑮ Packing type	Blank: the block and rail are assembled B: block and rail are put separately	
⑯ Rail type	Blank: Top-mount T: Bottom-mount	
⑰ Self-lubricator Standard Type	E: Self-lubricator Standard Type	

[Note1] Number of joints cannot be more than 2 times(three rails at most).

For LSQH15/20/25, maximum length of jointed rail is 11800mm.

For LSQH30/35, it's 11880. Customization is needed for joint times more than standard.

[Note2] Heavy preload is available for LSQH25/30/35 only.

[Note3]LSQH15 only Square(H) and Flange mounting from top(F1) block styles are available.

[Note4] For LSQH-BB series, standard length of a rail is 3 m.

Maximum length of two-joint rail is 6 m. Maximum length of three-joint rail is 9 m.

Please contact with our company if length of rail exceeds the maximum.

LSQH Series

1. Block Order Information

LSQH □ 20 BK-H N - H - D - AM8- E

① ② ③ ④ ⑤ ⑥ ⑦ ⑧ ⑨ ⑩

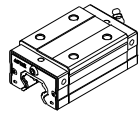

N: Standard

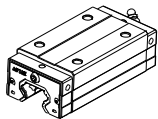

L: Long

① Model Code	LSQH: Self-lubricator Standard Linear Guide					
② Coating on block	Blank: Block without additional coating. (natural color) ★ B: Block coated with black chrome					
③ Rail Width	15: 15mm 20: 20mm 25: 23mm 30: 28mm 35: 34mm					
④ Block Code	BK: Block					
⑤ Block Style	H: Square type F1: Flange type, Mounting from top F2: Flange type, Mounting from bottom F3: Flange type, Mounting from top or bottom					
⑥ Block type	N: Standard L: Long [w/o 15 series]					
⑦ Accuracy	N: Normal H: High					
⑧ Group code	SA SB SC SE SF B C D [Note1]					
⑨ Nipple /adapter type	15	M4: M4 Nipple		20 25 30 35	M6: M6 Nipple	
		AM6: M4 to M6	I type		A01: M6 to PT1/8	I type
		LM6: M4 to M6	L type		L01: M6 to PT1/8	L type
						LM8: M6 to M8
						SM6: M6 Nipple
⑩ Self-lubricator Standard Type	E: Self-lubricator Standard Type					

[Note 1]: When selecting rails and bearings, the different pairing codes can change the units preload. details see "preload pairing chart".

[Note 2] LSQH15 only Square(H) and Flange mounting from top(F1) block styles are available.

LSQH Series

Self-lubricator illustration

1. Code and structure

AirTAC provides self-lubricator for applications e.g. limited spaces, or where grease maintenance is challenging.

If needed, please add the code "E" after the product model.

E.g. LSQH20HN1X220S20AH-AM8 - B - T - E

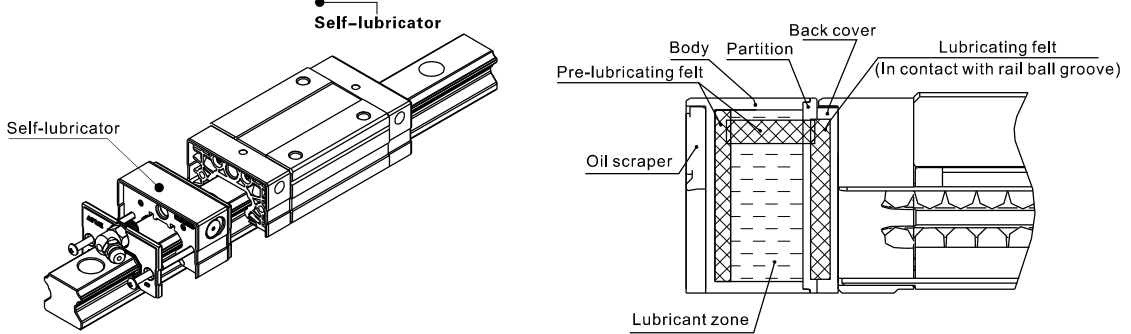

Product Features

1. Easy Maintenance and Long-Term Maintenance-Free Operation: In normal applications, basically no additional grease maintenance is required throughout lifespan of linear guide.
 2. Cost Savings: No additional lubrication is needed for the block, reducing labor and material costs.
 3. Flexible Use in Specific Environments: Equipped with a high-capacity grease tank, allowing the use of specific lubricants for specific environments.
 4. Dustproof Design: Built-in dustproof structure extends lifespan.
 5. Flexible in usage and installation: the assembling and disassembling of self-lubricator in integrity structure is convenient, can have it according to different working condition.
- [Note] Self-lubricator type block is not applicable for ultra-smooth application, as the higher viscosity of the lubricant in self-lubricator will increase friction by approximately 5-7N.

Durability test of self-lubricator

Test specification

Test specification	Model	Speed	Stroke	Lubricant type
Lubricating effect	LSQH20	30m/min	1200mm	ISO VG680 high-quality extreme pressure lubricant

Test result

Test result shows that after running 1,000 km, only 20% of the grease is consumed, and the linear guide remains lubricated. The expected service life can possibly exceed 4,000 km.

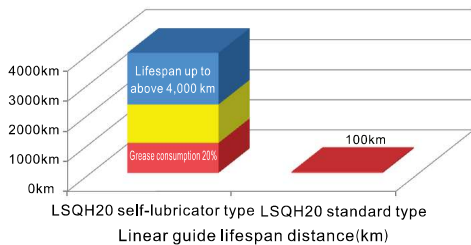

When comparing each sub-series with the self-lubricator and the standard model, the length of block will change. Please refer to the table below for details.

- Block dimension comparison (only dimension C is different from the standard, the rest remains the same)

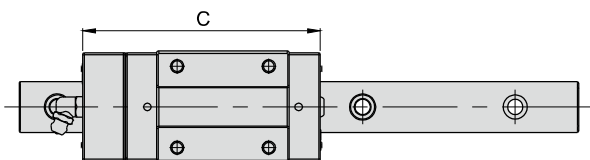

Model	Type	Length C(mm)	
		Standard (Blank)	Self-lubricator Standard Type
LSQH15□N	Standard	61.5	77
LSQH20□N	Standard	77	94
LSQH20□L	Long	92	109
LSQH25□N	Standard	83.5	100.5
LSQH25□L	Long	104.5	121.5
LSQH30□N	Standard	97.5	114.5
LSQH30□L	Long	122	139
LSQH35□N	Standard	113	130
LSQH35□L	Long	140.5	157.5

Precautions on use

1. Block disassembly

With ball retainers and a dustproof cover, normally the balls are prevented from falling out when block is removed from rail. However, if obliquely insert rail into blocks or quickly assembled or disassembled, there is a risk for balls of falling out. Please carefully assemble the linear guide or use plastic rails to assist.

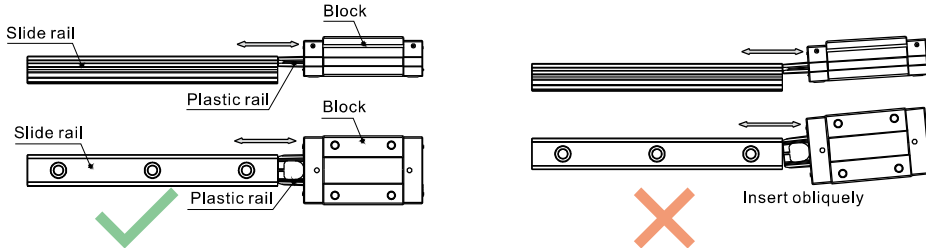

2. Plastic rail installation

A plastic rail is equipped for individual block set. Please do not remove plastic rail whenever it is not necessary. If plastic rail falls out and needs to be reinstalled, press the dustproof covers with fingers and install slowly to prevent balls from falling out due to misalignment of plastic rail.

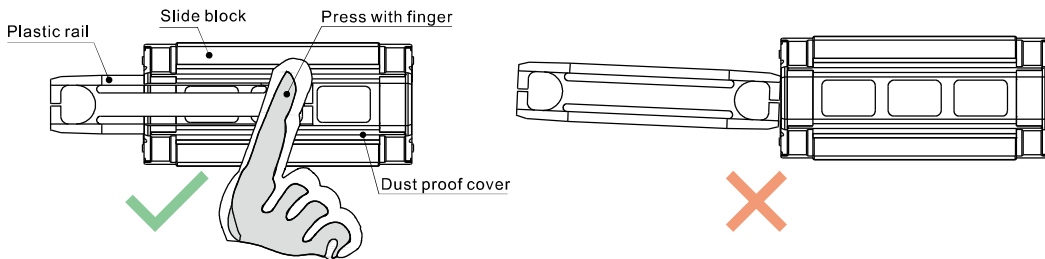

Press the dust-proof covers and insert plastic rail in alignment.

Without pressing dust-proof covers or insert plastic rail obliquely.

3. Caution

- Parts may slide out if linear guide is put unevenly. Please be careful.
- Hitting or dropping linear guide could have huge effect on accuracy and lifespan even though appearance may remain intact. Please be careful.
- Do not disassemble linear guide as external objects may enter blocks and cause accuracy problem.

4. Lubrication

- Linear guide have been treated with anti-rust oil during production. Before use, wipe the rail and treat it with lubrication.
- Do not mix lubricating oil (grease) with different properties.
- After lubrication, move block back and forth for the length of three blocks long and repeat at least 2 times to ensure there is a grease file on rail.

5. Use

- The operating environment temperature should not exceed 80°C, and the maximum temperature should not exceed 100°C.
- Do not separate blocks from rail whenever it is not necessary. If you need to separate them, please use plastic rails to prevent steel balls from falling out.

6. Storage

- When storing blocks, rails or linear guide set, please be sure that anti-rust oil is well applied and product is well sealed as well as placed horizontally. Avoid humidity and high temperatures environment.



LRW Series Miniature Linear Guide (Widened)

Product Introduction

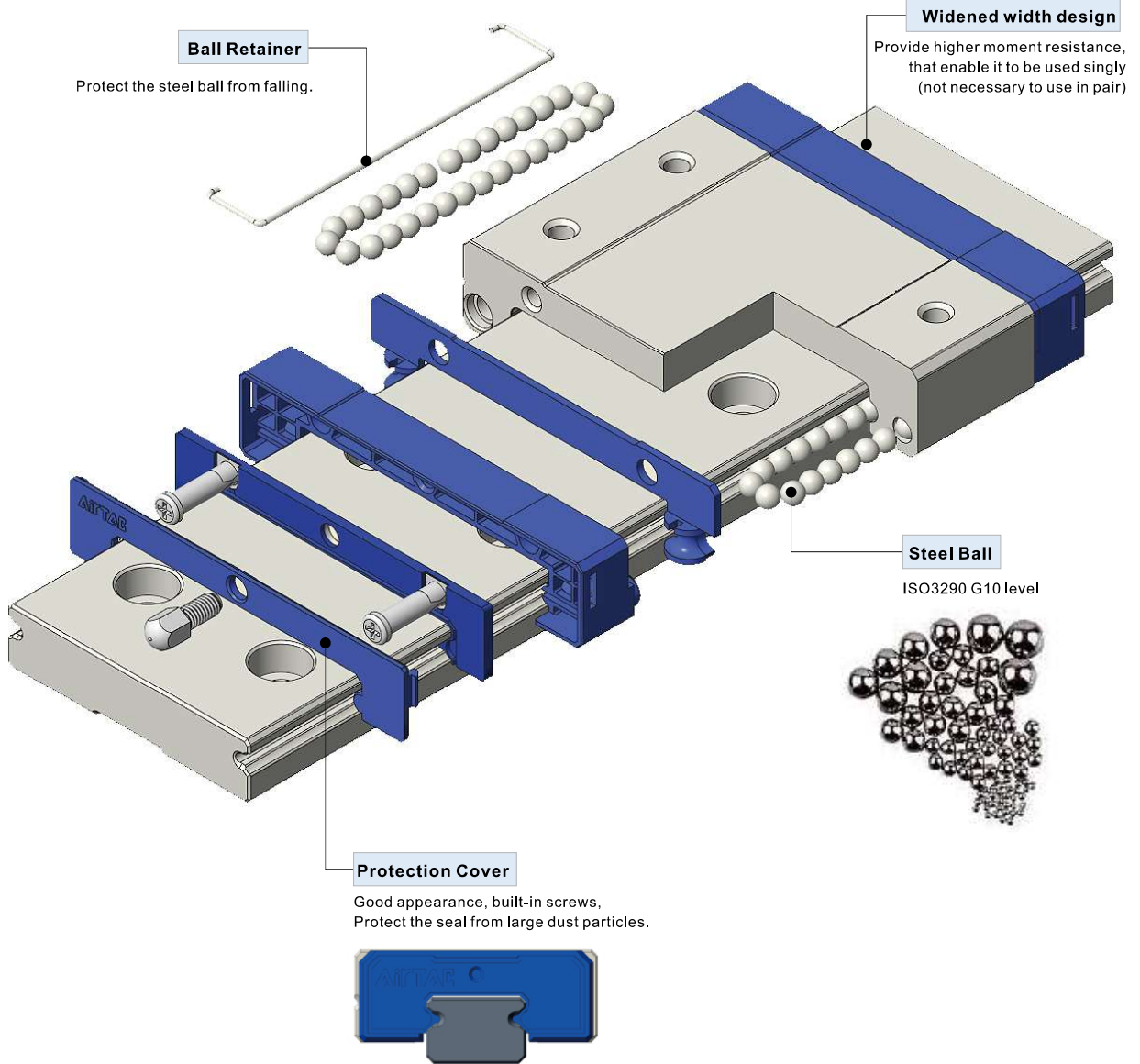

Miniature Linear Guide (Widened)

LRW Series

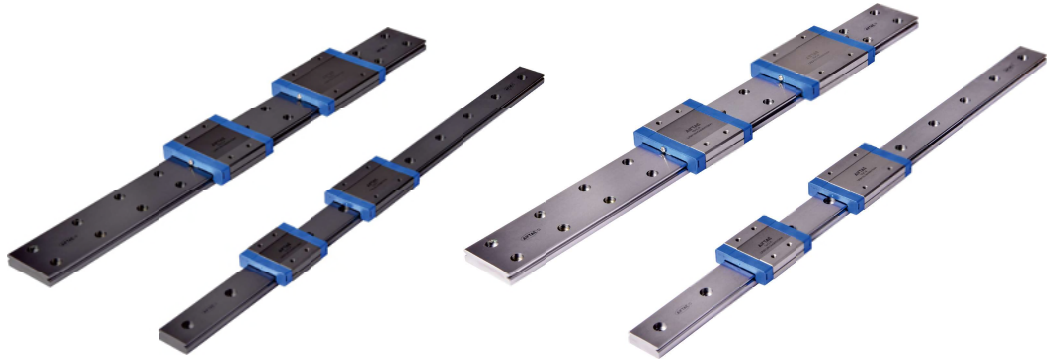

Order Information(Combined)

LRW □ 7 N 1 X40 S5 A H T

① ② ③ ④ ⑤ ⑥ ⑦ ⑧ ⑨ ⑩

① Model Code	LRW: Miniature Linear Guide (Widened)
② Rail&Block surface treatment	Blank: without additional coating. (natural color) ★BB: Block and rail coated with black chrome
③ Rail Width	7: 14mm 9: 18mm 12: 24mm 15: 42mm
④ Block type	N: Standard L: Long
⑤ Number of Block	1: One 2: Two [Note: Amount of block on a single set of linear guide]
⑥ Length of Rail	40: 40mm[Defined by customer]
⑦ Position of first mounting hole	□ : Distance from end of rail to the center of first mounting hole (It is recommended to be greater than minimum margin) [Refer to rail spec. Table for details]
⑧ Preload	A: Standard clearance B: Light Preload C: Medium Preload
⑨ Accuracy	N : Normal H : High P : Precision
⑩ Rail type	Blank: Top-mount T: Bottom-mount

Butt-jointed Order Information

LRW □ 7 N 1X1030 T 1030 A H T

① ② ③ ④ ⑤ ⑥ ⑦ ⑧ ⑨ ⑩ ⑪

① Model Code	LRW: Miniature Linear Guide (Widened)
② Rail&Block surface treatment	Blank: without additional coating. (natural color) ★BB: Block and rail coated with black chrome
③ Rail Width	7: 14mm 9: 18mm 12: 24mm 15: 42mm
④ Block type	N: Standard L: Long
⑤ Number of Block	1: One 2: Two [Note: Amount of block on a single set of linear guide]
⑥ Length of first Rail	1030: 1030mm[Defined by customer]
⑦ Butt-jointed mark	T: Rail Butt-jointed mark (Butt-jointed end margin: 1/2P) [P is the standard hole distance]
⑧ Length of second Rail	1030: 1030mm[Defined by customer]
⑨ Preload	A: Standard clearance B: Light Preload C: Medium Preload
⑩ Accuracy	N : Normal H : High
⑪ Rail type	Blank: Top-mount T: Bottom-mount

[Note 1] Number of joints cannot be more than 2 times. Customization is needed for joint times more than standard.
[Note2] Customization is needed is the first/last mounting hole position is out of range in 'Rail Specification Table'.

Butt-jointed end margin: 1/2P ,
Position of the first and last
hole is defined by customer.

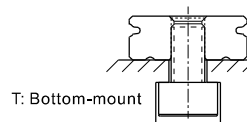
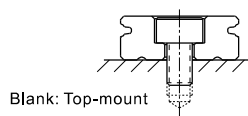

Miniature Linear Guide (Widened)

LRW Series

1. Block Order Information

LRW □ 7 BK - N - H - D



[Note1] When selecting rails and bearings, the different pairing codes can change the units preload. details see "preload pairing chart".

① Model Code	LRW: Miniature Linear Guide (Widened)
② Coating on block	Blank: Block without additional coating. (natural color) ★ B: Block coated with black chrome
③ Rail Width	7: 14mm 9: 18mm 12: 24mm 15: 42mm
④ Block Code	BK: Block
⑤ Block type	N: Standard L: Long
⑥ Accuracy	N: Normal H: High
⑦ Group code	B C D E [Note1]

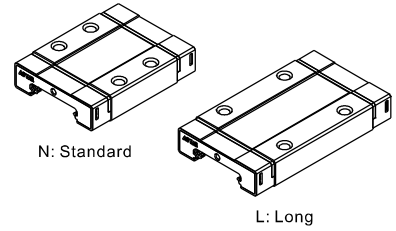

2. Rail(2m) Order Information

LRW □ 7 RLX2000 - H - E - T

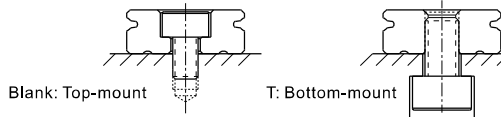

① Model Code	LRW: Miniature Linear Guide (Widened)
② Coating on rail	Blank: Rail without additional coating. (natural color) ★ B: Rail coated with black chrome
③ Rail Width	7: 14mm 9: 18mm 12: 24mm 15: 42mm
④ Rail Code	RL: Rail
⑤ Rail Length	2000: 2000mm
⑥ Accuracy	N: Normal H: High
⑦ Group code	E [Note1]
⑧ Rail type	Blank: Top-mount T: Bottom-mount

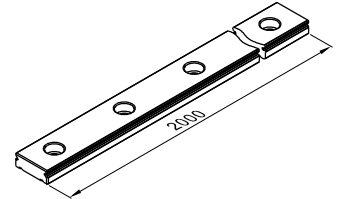

[Note1] When selecting rails and bearings, the different pairing codes can change the units preload. details see "preload pairing chart".

3. Rail Order Information

LRW □ 7 RLX40-S5 - H - E - T



[Note1] When selecting rails and bearings, the different pairing codes can change the units preload. details see "preload pairing chart".

① Model Code	LRW: Miniature Linear Guide (Widened)
② Coating on rail	Blank: Rail without additional coating. (natural color) ★ B: Rail coated with black chrome
③ Rail Width	7: 14mm 9: 18mm 12: 24mm 15: 42mm
④ Rail Code	RL: Rail
⑤ Rail Length	40: 40mm[Defined by customer]
⑥ Position of first mounting hole	S ₀ : Distance from end of rail to the center of first mounting hole (It is recommended to be greater than minimum margin) [Refer to rail spec. Table for details]
⑦ Accuracy	N: Normal H: High
⑧ Group code	E [Note1]
⑨ Rail type	Blank: Top-mount T: Bottom-mount

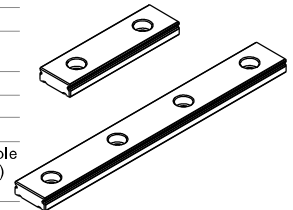

4. Accessory(Bolt hole plug)Order Code

L - BC - M3 - 10P



Note: 1. Bolt hole plugs are packed in one bag per 10pcs. EX: When ordering 1pc of "L-BC-M3-10P", it comes with 10pcs plugs;
2. "L-BC-M3-10P" is applied to LRW7/9 series, "L-BC-M4-10P" is applied to LRW12/15 series.
3. When mounting plugs for LRW7/12/15 series, short head bolts are required, bolt size is shown in the following figure.

① Accessory	L: Linear Guide Accessories
② Plug Code	BC: Bolt hole plug
③ Plug Specification	M3: Used for M3 bolt M4: Used for M4 bolt
④ Plug quantity	10P: 10pcs/bag

Model	A
LRW7	≤2
LRW12	≤2.6
LRW15	≤2.6

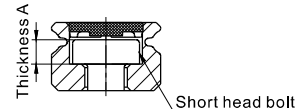

5. Rail/Block preload pairing chart

When customer orders rail/block, please choose the pairing code of rail/block in accordance with the needed preload of linear guide(combined). Details please refer to the "preload pairing chart".

Model	Rail pairing code	Block pairing code	Preload grade	Model	Rail pairing code	Block pairing code	Preload grade
LRW7 LRW9	E	B	-	LRW12 LRW15	E	B	Medium preload
		C	Medium preload			C	Light preload
		D	Light preload			D	-
		E	Standard clearance			E	Standard clearance

LRW Series

Rail Specification

- Please refer to the chart for maximum individual rail length and Edge pitch information.
- The edge pitch of first mounting hole (S) and last mounting hole (E) should not be greater than 1/2P. Overlong edge may induce unstable installation and affect the accuracy.
n: Numbers of mounting holes

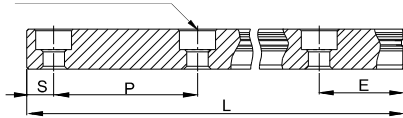

$L = (n-1) \times P + S + E$
 L: Total length of rail(mm)
 n: Numbers of mounting holes on rail
 P: Distance between bolt holes(mm)
 S: Edge of first mounting hole(mm)
 E: Edge of last mounting hole(mm)

Model	LRW7	LRW9	LRW12	LRW15
Pitch(P)	30	30	40	40
2m Standard Edge Pitch(S)	10	10	15	15
2m Standard Edge Pitch(E)	10	10	25	25
Min. Edge Pitch(S/E min)	4	4	5	5
Max. Edge Pitch(S/E max)	26	26	35	35
Maximum length(Lmax)	2000	2000	2000	2000

Note:

- Joint rail must be chosen if length of rail exceeds the maximum.
- When deciding edge pitch, it should be within the range of above table. There would be risk of broken hole if pitch is out of range.
- Maximum length of rail for standard' means the maximum length of rail can be chosen when both sides of edge pitches are standard.

Specifications and Dimensions

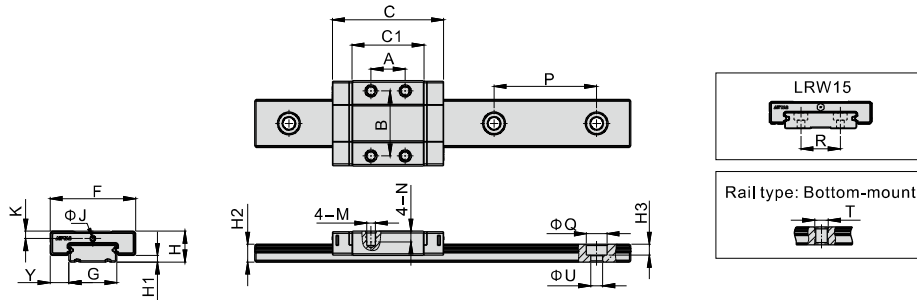

Model/Item	External Dimension (mm)					Block Dimension (mm)							Rail Dimension (mm)							
	H	H1	F	Y	C	C1	A	B	M	N	K	J	G	R	H2	P	ΦQ	ΦU	H3	T
LRW7N	9	1.9	25	5.5	32.5	21	10	19	M3X0.5	3	2.15	1.2	14	-	5.2	30	6	3.5	3.2	M4X0.7
LRW7L	9	1.9	25	5.5	42	30.5	19	19	M3X0.5	3	2.15	1.2	14	-	5.2	30	6	3.5	3.2	M4X0.7
LRW9N	12	3	30	6	40	27.5	12	21	M3X0.5	3	2.85	1.2	18	-	7.3	30	6	3.5	4.5	M4X0.7
LRW9L	12	3	30	6	52	39.5	24	23	M3X0.5	3	2.85	1.2	18	-	7.3	30	6	3.5	4.5	M4X0.7
LRW12N	14	3	40	8	46	31	15	28	M3X0.5	3.5	3.15	1.2	24	-	8.5	40	8	4.5	4.5	M5X0.8
LRW12L	14	3	40	8	61	46	28	28	M3X0.5	3.5	3.15	1.2	24	-	8.5	40	8	4.5	4.5	M5X0.8
LRW15N	16	2.7	60	9	57.5	39.3	20	45	M4X0.7	4.5	3.45	M3	42	23	9.5	40	8	4.5	4.5	M5X0.8
LRW15L	16	2.7	60	9	76.5	58.3	35	45	M4X0.7	4.5	3.45	M3	42	23	9.5	40	8	4.5	4.5	M5X0.8

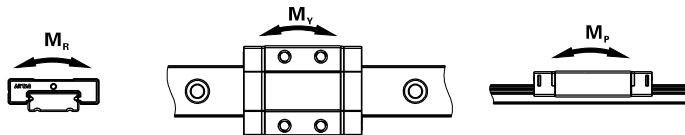

Model/Item	Mounting Screw	Dynamic Load Rating(kN)			Static Load Rating(kN)			Static Rated Moment (N.m)			Weight	
		C_{100B}			C_0			M_R	M_P	M_V	Block(kg)	Rail(kg/m)
LRW7N	M3	1.07			1.96			14.92	6.78	6.78	0.022	0.505
LRW7L	M3	1.47			2.98			22.28	14.75	14.75	0.030	0.505
LRW9N	M3	2.03			3.91			38.11	18.01	18.01	0.041	0.933
LRW9L	M3	2.69			5.60			51.81	32.30	32.30	0.055	0.933
LRW12N	M4	3.13			5.31			85.82	26.41	26.41	0.073	1.492
LRW12L	M4	4.08			7.83			97.57	54.50	54.50	0.105	1.492
LRW15N	M4	5.26			8.76			189.37	53.83	53.83	0.154	2.885
LRW15L	M4	6.99			12.71			284.06	116.47	116.47	0.223	2.885

Accuracy

LRW standard type linear guide comes with 3 accuracy levels.

Accuracy Standards (mm)	Accuracy Standards (mm)			
	Accuracy	N : Normal	H: High	P: Precision
Tolerance of height H	±0.04	±0.02	±0.01	
Variation of height ΔH	0.03	0.015	0.007	
Tolerance of width Y	±0.04	±0.025	±0.015	
Variation of width ΔY	0.03	0.02	0.01	

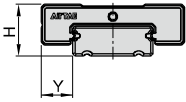

Parallelism of the raceway

Accuracy Rail Length(mm)	Parallelism of theraceway(μm)		
	N	H	P
50 under	12	6	2
50~80	13	7	3
80~125	14	8	3.5
125~200	15	9	4
200~250	16	10	5
250~315	17	11	5
315~400	18	11	6
400~500	19	12	6
500~630	20	13	7
630~800	22	14	8
800~1000	23	16	9
1000~1200	25	18	11
1200~1300	25	18	11
1300~1400	26	19	12
1400~1500	27	19	12
1500~1600	28	20	13
1600~1700	29	20	14
1700~1800	30	21	14
1800~1900	30	21	15
1900~2000	31	22	15
2000-	31	22	16

Preload Level

The LRW standard type Linear Guide has three preload categories: A, B and C.

Choosing suitable preload level will enhance rigidity, precision and torsion resistant performance of the linear guide.

Preload	Code	Radial interference (μm)				Application
		7	9	12	15	
Standard clearance	A	-2~+2	-2~+2	-2~+3	-2~+3	Smooth operation
Light Preload	B	-4~-2	-5~-2	-6~-2	-7~-2	High precision
Medium Preload	C	-7~-3	-8~-4	-9~-5	-10~-6	High rigidity

Load Capacity and Rating Life

1. Basic static load rating (C₀)

It is defined as the static load when the total permanent deformation of the steel ball and the surface of the groove is exactly one ten-thousandth of the diameter of the steel ball under the state of the load direction and size unchanged.

2. Allowable static moment (M₀)

When the steel ball subjected to the maximum stress in the slider reaches a static rated load condition, this loading moment is called the "Static permissible moment". The definition comes in three directions.

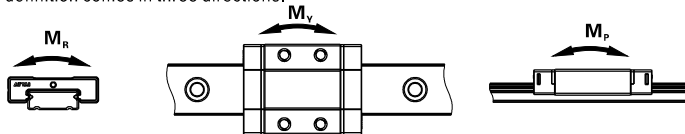

3. Static safety factor (f_s)

Impact, vibration and inertial loading during start and stop moment lead to unexpected load on the linear guide way. Therefore, when calculating the static load, safety factors must be considered.

Load Condition	f _s
Normal Load	1.0~2.0
Load with Impacts or Vibrations	2.0~3.0

$$f_s = \frac{C_0}{P} = \frac{M_0}{M}$$

- f_s : Static safety factor
- C₀ : Basic static load rating (N)
- M₀ : Static permissible moment (N.m)
- P : Calculated working load (N)
- M : Calculated applying moment (N.m)

4. Load factor (f_L)

The loads acting on a linear guide way include the weight of block, the inertia load at the times of start and stop, and the moment loads caused by overhanging. Therefore, the load on a linear guide way should be divided by the empirical factor.

Loading condition	Use speed	f _L
No impacts & vibration	V ≤ 15m/min	1~1.2
Small impacts	15m/min < V ≤ 60m/min	1.2~1.5
Normal load	60m/min < V ≤ 120m/min	1.5~2.0
With impacts & vibration	V > 120m/min	2.0~3.5

5. Basic dynamic load rating (C_{100B})

C_{100B} : (According to ISO 14728-1) As the direction and magnitude remains the same, C_{100B} is the maximum workload for the product to maintain its nominal life at 100km of operation.

LRW Series

6. Calculation of Nominal Life(L)

Recognizing that nominal life of a linear guide is affected by the actual working loads, the general calculation of the nominal life excluding the environmental factors is carried out as follow: :

$$L = \left(\frac{C_{1000}}{f_w \times P} \right)^3 \times 10^6$$

L = Nominal Life (m)

C₁₀₀₀ = Dynamic Load Rating (N)

f_w: Load Factor

P = Equivalent load (N)

Taking LRW9N for example, its C₁₀₀₀ is 2.03kN. Therefore, when the product bears a 1.5kN equivalent load P、f_w=1, its theoretical rated life can be calculated as follows:

$$L = \left(\frac{C_{1000}}{f_w \times P} \right)^3 \times 10^6 = \left(\frac{2.03}{1 \times 1.5} \right)^3 \times 10^6 = 247865 \text{ m} = 247.9 \text{ km}$$

Installation Illustration

1. Height and Chamfer of Reference Edge

In order to ensure accurate installation of LRW Linear Guide, the contact space should not exceed the given figures in following table.

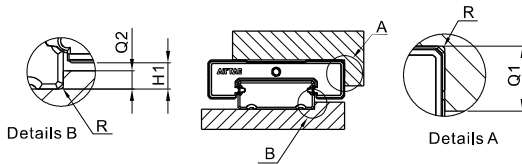

Unit : mm

Model	Q1	Q2	H1	R(Max)
LRW7	3	1.6	1.9	0.2
LRW9	3	2.7	3	0.3
LRW12	4	2.7	3	0.4
LRW15	5	2.4	2.7	0.5

2. Screw Tighten Torque

When installing linear guide, whether the screws are well tighten and surface is well contacted will affect accuracy significantly. Please refer to following table for tightening force to ensure a perfect installation.

Model	Screw size	Tighten Torque(N.cm)		
		Iron	Casting	Aluminum alloy
LRW7	M3	196	127	98
LRW9				
LRW12	M4	412	274	206
LRW15				

3. Datum plane

- Datum plane for installation must be ground or finely milled to ensure accuracy.
- Both sides of Rail can be used as the datum plane.
- For multi-blocks on a rail, identification line on blocks should be put on the same side to ensure moving accuracy.

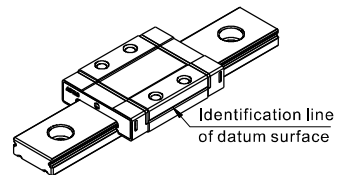

Rail Butt-jointed

- When jointing rails, it must follow group marks on rail to ensure the accuracy of linear guide. These marks are located on the top surface at joint side. Please put the same group marks together.

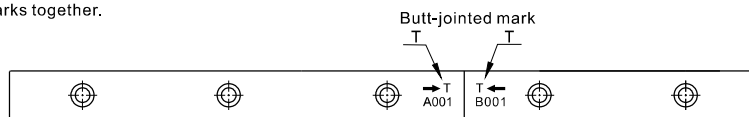

- Be aware serial number of group mark when assemble. A001 and B001 are in a group, so as to A002 and B002 and so on.
- Be aware the installation direction while assembly, the serial numbers are not upside down and arrows point to each other.

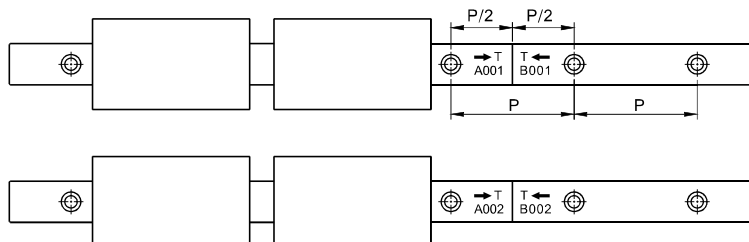

LRW Series

Lubrication method

When a linear guide is well lubricated, it can reduce wear and increase lifespan significantly. Lubrication has the following benefits :

- Reduces friction of the rollers and raceway to minimize wear.
- The grease film between contact surface can prevent roller fatigue.
- Prevent rust.

1. Lubrication method

LRW series linear guide is well lubricated with 'Shell Alvania grease S2' in factory. Customers are recommended to use identical or the same grade of lubricant. Refer to table on the right for suggested amount:
In order to be well lubricated, the blocks need to be moved back and forth while lubricating. Lubrication can be done either by manual or automatic device.

Model	Grease amount for the first lubrication(cm ³)	Replenishment amount(cm ³)
LRW7N	0.17	0.09
LRW7L	0.2	0.1
LRW9N	0.27	0.14
LRW9L	0.36	0.18
LRW12N	0.45	0.23
LRW12L	0.6	0.3
LRW15N	0.81	0.41
LRW15L	1.06	0.53

2. Lubrication frequency

Although the linear guides are well lubricated at the factory and retains grease well, frequent lubrication is still necessary to avoid undesirable wear. Recommended lubrication period is every 100km of movement or every 3~6 months. (Refer to table on the right for suggested amount)

Precautions on use

1. Block disassembly

With ball retainers, normally the balls are prevented from falling out when block is removed from rail. However, if obliquely insert rail into blocks or quickly assembled or disassembled, there is a risk for balls of falling out. Please carefully assemble the linear guide or use plastic rails to assist.

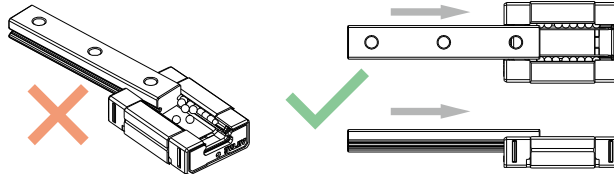

2. Caution

- Parts may slide out if linear guide is put unevenly. Please be careful.
- Hitting or dropping linear guide could have huge effect on accuracy and lifespan even though appearance may remain intact. Please be careful.
- Do not disassemble linear guide as external objects may enter blocks and cause accuracy problem.

3. Lubrication

- Linear guide have been treated with anti-rust oil during production. Before use, wipe the rail and treat it with lubrication.
- Do not mix lubricating oil (grease) with different properties.
- After lubrication, move block back and forth for the length of three blocks long and repeat at least 2 times to ensure there is a grease file on rail.

4. Use

- The operating environment temperature should not exceed 80°C, and the maximum temperature should not exceed 100°C.
- Do not separate blocks from rail whenever it is not necessary. If you need to separate them, please use plastic rails to prevent steel balls from falling out.

5. Storage

- When storing blocks, rails or linear guide set, please be sure that anti-rust oil is well applied and product is well sealed as well as placed horizontally. Avoid humidity and high temperatures environment.



LRM Series Miniature Linear Guide

Product Introduction

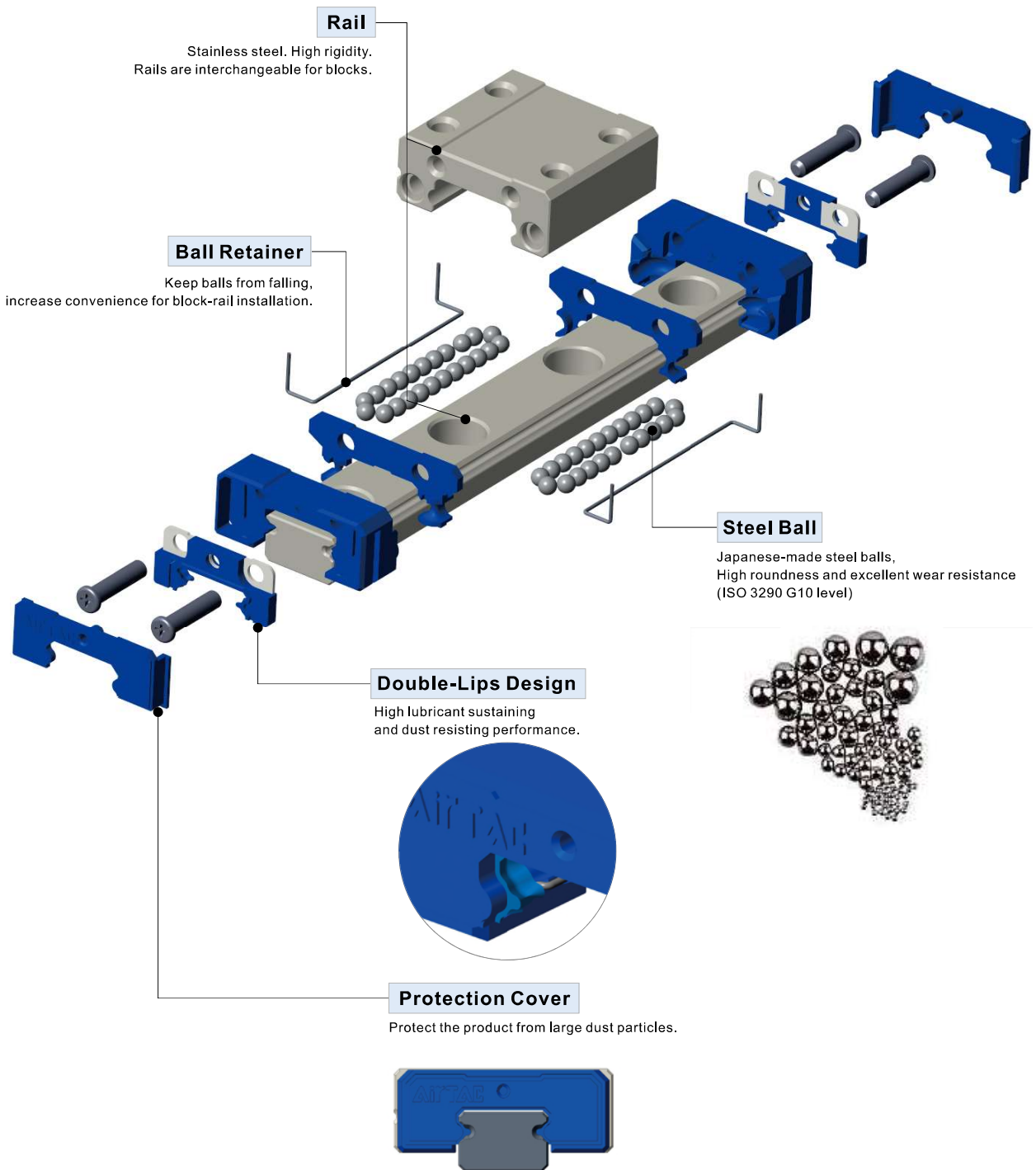

LRM Series



Order Information(Combined)

LRM □ 7 N 1 X40 S5 A H T

① ② ③ ④ ⑤ ⑥ ⑦ ⑧ ⑨ ⑩

① Model Code	LRM : Miniature Linear Guide	
② Rail&Block surface treatment	Blank: without additional coating, (natural color) ★BB: Block and rail coated with black chrome	
③ Rail Width	5 : 5mm 7 : 7mm 9 : 9mm 12 : 12mm 15 : 15mm	
④ Block type	N: Standard L: Long	
⑤ Number of Block	1: One 2: Two [Note: Amount of block on a single set of linear guide]	
⑥ Rail Length	40: 40mm..... [Refer to rail spec. table for detail]	
⑦ Position of first mounting hole	S□ : Distance from end of rail to the center of first mounting hole. (It is recommended to be greater than minimum edge) [Refer to rail spec table for details]	
⑧ Preload	A: Standard clearance B: Light Preload C: Medium Preload	
⑨ Accuracy	H: High P: Precision	
⑩ Rail type	Blank : Top-Mount T : Bottom-Mount	

Note: LRM5 without black chrome plating option

Butt-jointed Order Information

LRM □ 7 N 1 X 705 T 705 A H T

① ② ③ ④ ⑤ ⑥ ⑦ ⑧ ⑨ ⑩ ⑪

① Model Code	LRM : Miniature Linear Guide	
② Rail&Block surface treatment	Blank: without additional coating, (natural color) ★BB: Block and rail coated with black chrome	
③ Rail Width	5 : 5mm 7 : 7mm 9 : 9mm 12 : 12mm 15 : 15mm	
④ Block type	N: Standard L: Long	
⑤ Number of Block	1: One 2: Two [Note: Amount of block on a single set of linear guide]	
⑥ Length of first Rail	705: 705mm[Defined by customer]	
⑦ Butt-jointed mark	T: Rail Butt-jointed mark(Butt-jointed end margin:1/2P) [P is the standard hole distance]	
⑧ Length of tail Rail	705: 705mm[Defined by customer]	
⑨ Preload	A: Standard clearance B: Light Preload C: Medium Preload	
⑩ Accuracy	H: High	
⑪ Rail type	Blank : Top-Mount T : Bottom-Mount	

Butt-jointed end margin:1/2P ,
Position of the first and last
hole is defined by customer.

[Note 1] Allow only two rails for standard joint. Customization is needed for more than two rails.

[Note 2] Customization is needed if the first/last mounting hole position is out of range in 'Rail Specification Table'.

[Note 3] LRM5 without black chrome plating option

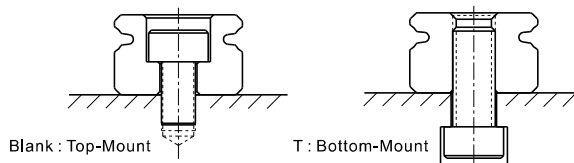

Blank : Top-Mount

T : Bottom-Mount

LRM Series

1. Block Order Information

LRM □ 7 BK - N - H - D

Notes: 1. When selecting rails and bearings, the different pairing codes can change the units preload, details see "preload pairing chart".
2. LRM5 block cannot be ordered individually.

① ② ③ ④ ⑤ ⑥ ⑦

① Model Code	LRM : Miniature Linear Guide
② Coating on block	Blank: Block without additional coating. (natural color) ★ B: Block coated with black chrome
③ Rail Width	7 : 7mm 9 : 9mm 12 : 12mm 15 : 15mm
④ Block Code	BK: Block
⑤ BlockType	N: Standard L: Long
⑥ Accuracy	H: High
⑦ Group Code	B C D E [Note]

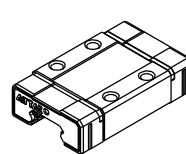

N: Standard

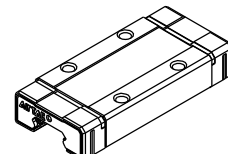

L: Long

2. Uncut Rail Order Information

LRM □ 7 RL X 985 - H - E - T

① ② ③ ④ ⑤ ⑥ ⑦ ⑧

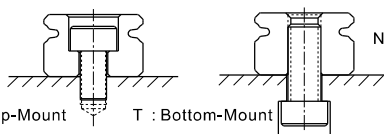

Blank : Top-Mount

T : Bottom-Mount

Note: 1. When selecting rails and bearings, the different pairing codes can change the units preload, details see "preload pairing chart".
2. LRM5 rail cannot be ordered individually.

① Model Code	LRM: Miniature Linear Guide
② Coating on rail	Blank: Rail without additional coating. (natural color) ★ B: Rail coated with black chrome
③ Rail Width	7:7mm 9:9mm 12:12mm 15:15mm
④ Rail Code	RL: Rail
⑤ Rail Length	985:985mm 995:995mm 995:995mm 990:990mm
⑥ Accuracy	H: High
⑦ Group Code	E [Note]
⑧ Rail Type	Blank: Top-Mount T: Bottom-Mount

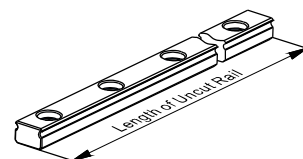

3. Rail Order Information

LRM □ 7 RLX40-S5-H-E-T

① ② ③ ④ ⑤ ⑥ ⑦ ⑧ ⑨

Note: 1. When selecting rails and bearings, the different pairing codes can change the units preload, details see "preload pairing chart".
2. LRM5 rail cannot be ordered individually.

① Model Code	LRM: Miniature Linear Guide
② Coating on rail	Blank: Rail without additional coating. (natural color) ★ B: Rail coated with black chrome
③ Rail Width	7 : 7mm 9 : 9mm 12 : 12mm 15 : 15mm
④ Rail Code	RL: Rail
⑤ Rail Length	40:40mm..... [Refer to rail spec. table for detail]
⑥ Position of first mounting hole	S □ : Distance from end of rail to the center of first mounting hole. (It is recommended to be greater than minimum edge) [Refer to rail spec table for details]
⑦ Accuracy	H: High
⑧ Group Code	E [Note]
⑨ Rail Type	Blank : Top-Mount T : Bottom-Mount

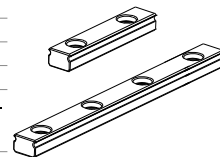

4. Accessory (Bolt hole plug) Order Code

L - BC - M3 - 10P

① ② ③ ④

Note:

1. Bolt hole plugs are packed in one bag per 10pcs, EX: When ordering 1pc of "L-BC-M3-10P", it comes with 10pcs plugs;
2. "L-BC-M3-10P" is applied to LRM9/12/15 series;
3. When mounting plugs for LRM9 series, short head bolts are required, bolt size is shown in the following figure.

① Accessories	L: Linear Guide Accessory
② Plug Code	BC: Bolt hole plug
③ Plug Specification	M3: Used for M3 bolt
④ Plug quantity	10P: 10pcs/bag

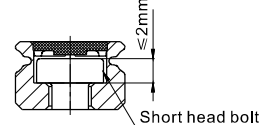

Short head bolt

5. Rail/Block preload pairing chart

When customer orders rail/block, please choose the pairing code of rail/block in accordance with the needed preload of linear guide(combined). Details please refer to the "preload pairing chart".

LRM7、LRM9 Preload pairing chart		
Preload grade	Rail pairing code	
	E	
Block pairing code	B	-
	C	Medium preload
	D	Light preload
	E	Standard clearance

LRM12、LRM15 Preload pairing chart		
Preload grade	Rail pairing code	
	E	
Block pairing code	B	Medium preload
	C	Light preload
	D	-
	E	Standard clearance

LRM Series

Rail Specification

1. Please refer to the chart for maximum individual rail length and Edge pitch information.

2. The edge pitch of first mounting hole (S) and last mounting hole (E) should not be greater than 1/2P. Overlong edge may induce unstable installation and affect the accuracy.

n: Numbers of mounting holes

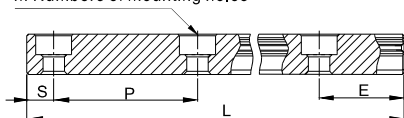

$$L = (n-1) \times P + S + E$$

L: Total length of rail (mm)

n: Numbers of mounting holes on rail

P: Distance between bolt holes (mm)

S: Edge of first mounting hole (mm)

E: Edge of last mounting hole (mm)

Model	LRM5	LRM7	LRM9	LRM12	LRM15
Pitch(P)	15	15	20	25	40
Maximum edge pitch (S/E)	5	5	7.5	10	15
Min. Edge Pitch (S/E min)	3	3	4	4	4
Max. Edge Pitch (S/E max)	10	10	15	20	35
Maximum length(L max)(mm)	490	985	995	995	990

Note: Joint rail must be chosen if length of rail exceeds the maximum.

- When deciding edge pitch, it should be within the range of above table. There would be risk of broken hole if pitch is out of range.

Specifications and Dimensions

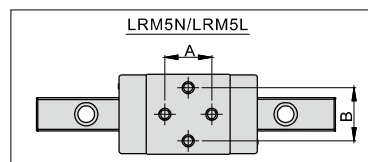
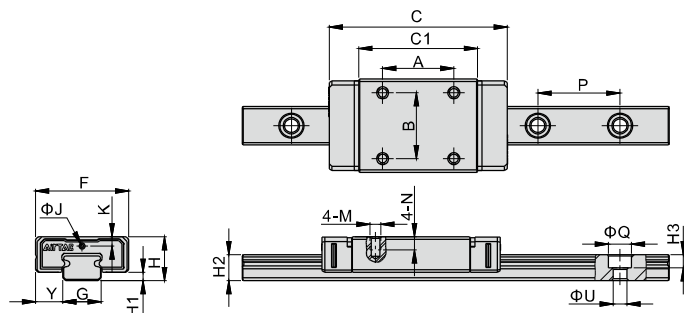

Rail type : Bottom-Mount

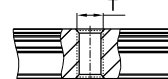

Model/Item	External Dimension (mm)					Block Dimension (mm)							Rail Dimension (mm)						
	H	H1	F	Y	C	C1	A	B	M	N	K	ΦJ	G	H2	P	ΦQ	ΦU	H3	T
LRM5N	6	1.5	12	3.5	18.2	10	7	8	M2X0.4	1.5	1.3	0.7	5	3.5	15	3.5	2.2	1.1	M3X0.5
LRM5L	6	1.5	12	3.5	21.2	13	7	8	M2X0.4	1.5	1.3	0.7	5	3.5	15	3.5	2.2	1.1	M3X0.5
LRM7N	8	1.5	17	5	24.3	13.5	8	12	M2X0.4	2.3	1.7	0.7	7	4.7	15	4.2	2.4	2.4	M3X0.5
LRM7L	8	1.5	17	5	32.5	21.7	13	12	M2X0.4	2.3	1.7	0.7	7	4.7	15	4.2	2.4	2.4	M3X0.5
LRM9N	10	2	20	5.5	31	18.9	10	15	M3X0.5	2.8	2.2	1	9	5.6	20	6	3.5	3.4	M4X0.7
LRM9L	10	2	20	5.5	42.1	30	16	15	M3X0.5	2.8	2.2	1	9	5.6	20	6	3.5	3.4	M4X0.7
LRM12N	13	3	27	7.5	37.6	21.7	15	20	M3X0.5	4	3	1.5	12	7.5	25	6	3.5	4.4	M4X0.7
LRM12L	13	3	27	7.5	48.4	32.5	20	20	M3X0.5	4	3	1.5	12	7.5	25	6	3.5	4.4	M4X0.7
LRM15N	16	3.5	32	8.5	48	28	20	25	M3X0.5	4	3.7	M3	15	9.5	40	6	3.5	4.4	M4X0.7
LRM15L	16	3.5	32	8.5	65	45	25	25	M3X0.5	4	3.7	M3	15	9.5	40	6	3.5	4.4	M4X0.7

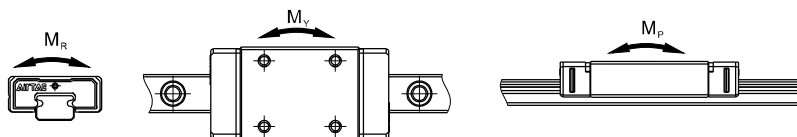

Model/Item	Mounting Screw	Dynamic Load Rating(kN)	Static Load Rating(kN)	Static Rated Moment (N.m)			Weight	
		C _{100B}	C ₀	M _R	M _P	M _V	Block(kg)	Rail(kg/m)
LRM5N	M2	0.33	0.55	1.68	0.99	0.99	0.0035	0.114
LRM5L	M2	0.48	0.9	2.4	2.08	2.08	0.004	0.114
LRM7N	M2	1.02	1.53	5.42	3.17	3.17	0.009	0.22
LRM7L	M2	1.43	2.45	9.27	7.96	7.96	0.014	0.22
LRM9N	M3	1.97	2.6	11.84	8.19	8.19	0.018	0.315
LRM9L	M3	2.61	4.11	19.73	18.94	18.94	0.027	0.315
LRM12N	M3	3.04	3.86	23.63	12.57	12.57	0.037	0.602
LRM12L	M3	3.96	5.9	40.96	32.57	32.57	0.053	0.602
LRM15N	M3	4.27	5.7	45.05	23.05	23.05	0.054	0.981
LRM15L	M3	6.53	9.53	70.08	63.69	63.69	0.088	0.981

Accuracy

LRM miniature linear guide comes with 2 accuracy levels.

Accuracy Standards (mm)	Accuracy Standards (mm)	
	H: High	P: Precision
Tolerance of height H	±0.02	±0.01
Variation of height ΔH	0.015	0.007
Tolerance of width Y	±0.025	±0.015
Variation of width ΔY	0.02	0.01

Parallelism of motion relative to benchmark surface.

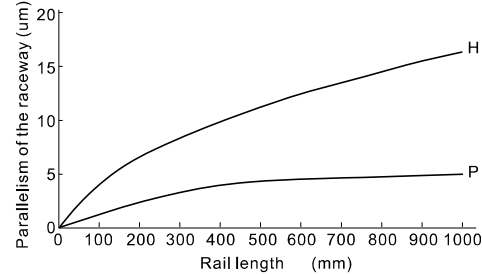

Preload Level

LRM Miniature Linear Guide has three preload categories: A, B and C.

Choosing suitable preload level will enhance rigidity, precision and torsion resistant performance of the linear guide.

Preload Level	Code	Radial interference (μm)					Application
		5	7	9	12	15	
Standard clearance	A	-1~+2	-2~+2	-2~+2	-2~+3	-2~+3	Smooth operation
Light Preload	B	-3~-1	-4~-2	-5~-2	-6~-2	-7~-2	High Precision
Medium Preload	C	-6~-2	-7~-3	-8~-4	-9~-5	-10~-6	High rigidity

Load Capacity and Rating Life

1. Basic static load rating (C₀)

It is defined as the static load when the total permanent deformation of the steel ball and the surface of the groove is exactly one ten-thousandth of the diameter of the steel ball under the state of the load direction and size unchanged.

2. Static Permissible Moment (M₀)

When the steel ball subjected to the maximum stress in the slider reaches a static rated load condition, this loading moment is called the "Static permissible moment". The definition comes in three directions.

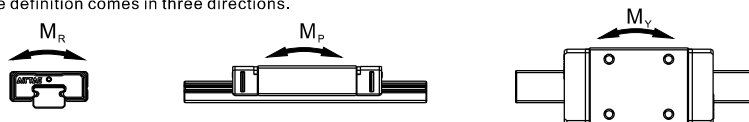

3. Static Safety Factor (f_s)

Impact, vibration and inertial loading during start and stop moment lead to unexpected load on the linear guide way.

Therefore, when calculating the static load, safety factors must be considered.

Load Condition	f _s
Normal Load	1.0~2.0
Load with Impacts or Vibrations	2.0~3.0

$$f_s = \frac{C_0}{P} = \frac{M_0}{M}$$

- f_s : Static safety factor
- C₀ : Basic static load rating (N)
- M₀ : Static permissible moment (N.m)
- P : Calculated working load (N)
- M : Calculated applying moment (N.m)

4. Load Factor (f_w)

The loads acting on a linear guide way include the weight of block, the inertia load at the times of start and stop, and the moment loads caused by overhanging. Therefore, the load on a linear guide way should be divided by the empirical factor.

Loading condition	Service speed	f _w
No impacts & vibration	V ≤ 15m/min	1~1.2
Small impacts	15m/min < V ≤ 60m/min	1.2~1.5
Normal load	60m/min < V ≤ 120m/min	1.5~2.0
With impacts & vibration	V > 120m/min	2.0~3.5

5. Dynamic Load Rating (C_{100B})

C_{100B} : (According to ISO 14728-1) As the direction and magnitude remains the same, C_{100B} is the maximum workload for the product to maintain its nominal life at 100km of operation.

LRM Series

6. Calculation of Nominal Life(L)

Recognizing that nominal life of a linear guide is affected by the actual working loads, the general calculation of the nominal life excluding the environmental factors is carried out as follow: :

$$L = \left(\frac{C_{1000}}{f_w \times P} \right)^3 \times 10^6$$

L = Nominal Life (m)

C₁₀₀₀ = Dynamic Load Rating (N)

f_w: Load Factor

P = Equivalent load (N)

Taking LRM9N for example, its C₁₀₀₀ is 1.97kN. Therefore, when the product bears a 1.5kN equivalent load P, f_w=1, its theoretical rated life can be calculated as follows:

$$L = \left(\frac{C_{1000}}{f_w \times P} \right)^3 \times 10^6 = \left(\frac{1.97}{1 \times 1.5} \right)^3 \times 10^6 = 226529 \text{ m} = 226.5 \text{ km}$$

Installation Illustration

1. Height and Chamfer of Reference Edge

In order to ensure accurate installation of LRM Linear Guide, the contact space should not exceed the given figures in following table.

Unit : mm

Model	Q1	Q2	H1	R(Max)
LRM5	2	1.2	1.5	0.2
LRM7	3	1.2	1.5	0.2
LRM9	3	1.7	2	0.3
LRM12	4	2.7	3	0.4
LRM15	5	3.2	3.5	0.5

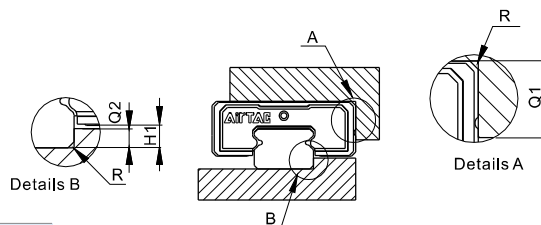

2. Screw Tighten Torque

Model	Screw size	Tighten Torque(N.cm)		
		Iron	Casting	Aluminum alloy
LRM5	M2	58.8	39.2	29.4
LRM7				
LRM9				
LRM12	M3	196	127	98
LRM15				

3. Datum plane

- Datum plane for installation must be ground or finely milled to ensure accuracy.
- Both sides of rail can be used as the datum plane.
- For multi-blocks on a rail, identification line on blocks should be put on the same side to ensure moving accuracy.

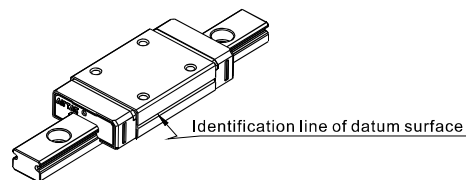

Rail Butt-jointed

- When jointing rails, it must follow group marks on rail to ensure the accuracy of linear guide. These marks are located on the top surface at joint side. Please put the same group marks together.

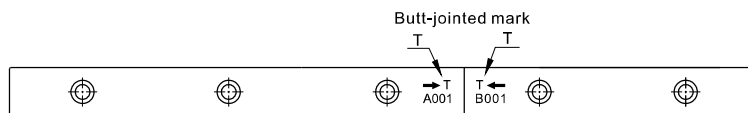

- Be aware serial number of group mark when assemble. A001 and B001 are in a group, so as to A002 and B002 and so on.
- Be aware the installation direction while assembly, the serial numbers are not upside down and arrows point to each other.

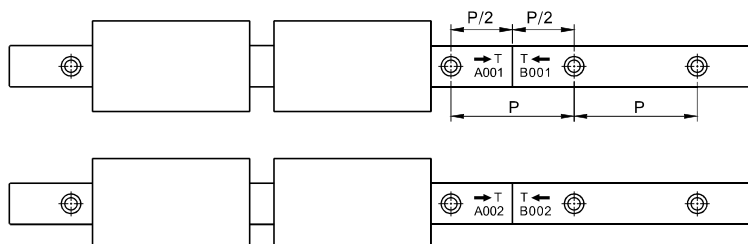

LRM Series

Lubrication Method

When a linear guide is well lubricated, it can reduce wear and increase lifespan significantly. Lubrication has the following benefits:

- Reduces friction of the rollers and rail to minimize wear.
- The grease film between contact surface can decrease the fatigue failure.
- Prevent rust.

1. Lubrication method

LRM series linear guide is well lubricated with 'Synergy Grease PS NO.2' in factory.

Customers are recommended to use identical or the same grade of lubricant.

Please refer to the right table for the amount of oil:

In order to be well lubricated, the blocks need to be moved back and forth after lubricating.

Lubrication can be done either by manual or automatic device.

Model	Initial lubrication (cm ³)	Replenishment amount (cm ³)
LRM5N	0.02	0.01
LRM5L	0.03	0.015
LRM7N	0.1	0.05
LRM7L	0.13	0.07
LRM9N	0.2	0.1
LRM9L	0.28	0.14
LRM12N	0.34	0.17
LRM12L	0.45	0.23
LRM15N	0.72	0.36
LRM15L	1.0	0.50

2. Lubrication frequency

Although the linear guides are well lubricated at the factory and retains grease well, frequent lubrication is still necessary to avoid undesirable wear.

Recommended lubrication period is every 100km of movement or every 3~6 months.

(Refer to table on the right for suggested amount).

Precautions on use

1. Block disassembly

LRM is equipped with ball retainers to prevent steel balls from falling out when block separates from rail. However, if obliquely insert rail into blocks or quickly assemble and disassemble, there is risk for steel balls of falling out. Please carefully assemble the linear guide or use plastic rails to assist.

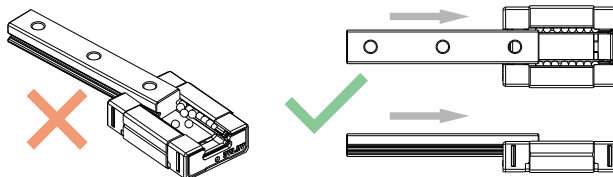

2. Caution

- Parts may slide out if linear guide is put unevenly. Please be careful.
- Hitting or dropping a linear guide could have huge effects on accuracy and lifespan even though appearance may remain intact. Please be careful.
- Do not separate linear guide as external objects may enter blocks and cause accuracy problem.

3. Lubrication

- Linear guide have been treated with anti-rust oil during production. Before use, wipe the rail and treat it with lubrication.
- Do not mix lubricating oil (grease) with different properties.
- While lubricating, the block needs to be moved back and forth. After lubrication, there should be a grease film on rail.

4. Use

- The operating environment temperature should not exceed 80°C, and the maximum temperature should not exceed 100°C.
- Do not separate blocks from rail whenever it is not necessary. If you need to separate them, please use plastic rails to prevent steel balls from falling out.

5. Storage

- When storing blocks, rails or set, please be sure that anti-rust oil is well applied and product is well sealed as well as placed horizontally. Avoid humidity and high temperatures environment.



LGC Series Crossed Roller Way

Product Introduction

Crossed Roller provides high rigidity and high accuracy linear movement with non-recirculating rollers design. By cross-arrangement of rollers, it will hugely reduce friction meanwhile provide high rigidity for rollers to bear heavy loads. Crossed roller is mainly used in high precision machine and measurement equipment such as circuit board printer, optical measurement instrument, X-ray equipment or base for multiple kinds of instruments.

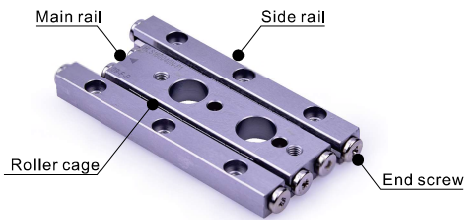

Three-Row Type Of Crossed Roller Way

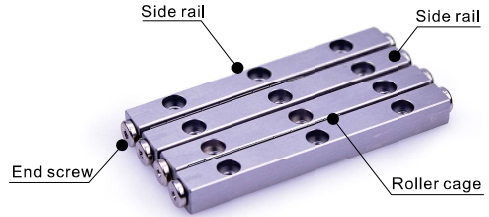

Four-Row Type Of Crossed Roller Way



Cylindrical roller with high precision roundness and wear resistance (JIS B 1506 G2) is manufactured in Japan

Order Information

LGC 3 A 200 R25 -H

① ② ③ ④ ⑤ ⑥



① Model Code	LGC : Crossed Roller Way	
② Roller Diameter	1 : Φ 1.5mm 2 : Φ 2.0mm 3 : Φ 3.0mm 4 : Φ 4.0mm 6 : Φ 6.0mm	
③ Type [Note]	A: Three-row type [Note] B: Four-row type	
④ Rail dimension	200: rail length 200X100: main rail length is 200mm/side rail length is 100mm [Reference to spec. table for detail]	
⑤ The number of rollers in each roller cage	R25: 25 rollers [Reference to spec. table for detail]	
⑥ Accuracy	H : High P : Precision	

[Note] LGC6: only for type B.



Cross Reference Table for Maximun Stroke & Roller numbers

LGC1 Max. Stroke (mm)	Numbers of rollers in one roller cage								
	R6	R7	R8	R9	R10	R11	R13	R16	R19
Shortest length of rails (mm)	20	12	7	-	-	-	-	-	-
	30	-	-	22	17	12	7	-	-
	40	-	-	-	-	-	27	17	-
	50	-	-	-	-	-	-	37	22
	60	-	-	-	-	-	-	-	42
	70	-	-	-	-	-	-	-	-
	70	-	-	-	-	-	-	-	-
	80	-	-	-	-	-	-	-	-

The standard quantity of rollers

Alternative options of the quantity of rollers

LGC2 Max. Stroke (mm)	Numbers of rollers in one roller cage														
	R6	R7	R8	R9	R10	R11	R13	R16	R19	R22	R25	R28	R32	R36	
Shortest length of rails (mm)	30	16	8	-	-	-	-	-	-	-	-	-	-	-	
	45	-	-	30	22	14	-	-	-	-	-	-	-	-	
	60	-	-	-	-	-	36	20	-	-	-	-	-	-	
	75	-	-	-	-	-	-	50	26	-	-	-	-	-	
	90	-	-	-	-	-	-	-	56	32	-	-	-	-	
	105	-	-	-	-	-	-	-	-	62	38	-	-	-	
	120	-	-	-	-	-	-	-	-	-	68	44	-	-	
	135	-	-	-	-	-	-	-	-	-	98	74	50	-	
	150	-	-	-	-	-	-	-	-	-	-	104	80	48	-
	165	-	-	-	-	-	-	-	-	-	-	-	110	78	45
	180	-	-	-	-	-	-	-	-	-	-	-	-	140	108

LGC3 Max. Stroke (mm)	Numbers of rollers in one roller cage													
	R7	R8	R9	R10	R11	R13	R16	R19	R22	R25	R28	R32	R36	R40
Shortest length of rails (mm)	50	34	24	14	-	-	-	-	-	-	-	-	-	-
	75	-	-	-	54	44	24	-	-	-	-	-	-	-
	100	-	-	-	-	74	44	-	-	-	-	-	-	-
	125	-	-	-	-	-	94	64	-	-	-	-	-	-
	150	-	-	-	-	-	-	114	84	54	-	-	-	-
	175	-	-	-	-	-	-	-	134	104	74	-	-	-
	200	-	-	-	-	-	-	-	-	154	124	84	-	-
	225	-	-	-	-	-	-	-	-	-	174	134	94	-
	250	-	-	-	-	-	-	-	-	-	-	184	144	104
	275	-	-	-	-	-	-	-	-	-	-	-	234	194
	300	-	-	-	-	-	-	-	-	-	-	-	-	244

LGC4 Max. Stroke (mm)	Numbers of rollers in one roller cage													
	R8	R9	R10	R11	R13	R16	R19	R22	R25	R28	R32	R36	R40	R45
Shortest length of rails (mm)	80	54	40	26	-	-	-	-	-	-	-	-	-	-
	120	-	-	-	92	64	-	-	-	-	-	-	-	-
	160	-	-	-	-	-	102	60	-	-	-	-	-	-
	200	-	-	-	-	-	-	140	98	56	-	-	-	-
	240	-	-	-	-	-	-	-	178	136	94	-	-	-
	280	-	-	-	-	-	-	-	-	216	174	118	-	-
	320	-	-	-	-	-	-	-	-	-	254	198	142	86
	360	-	-	-	-	-	-	-	-	-	-	278	222	166
	400	-	-	-	-	-	-	-	-	-	-	-	358	302
	440	-	-	-	-	-	-	-	-	-	-	-	-	382
	480	-	-	-	-	-	-	-	-	-	-	-	-	-

LGC6 Max. Stroke (mm)	Numbers of rollers in one roller cage												
	R8	R9	R11	R13	R16	R19	R22	R25	R28	R32	R36	R40	R45
Shortest length of rails (mm)	100	62	44	-	-	-	-	-	-	-	-	-	-
	150	-	-	108	72	-	-	-	-	-	-	-	-
	200	-	-	-	-	118	64	-	-	-	-	-	-
	250	-	-	-	-	-	164	110	56	-	-	-	-
	300	-	-	-	-	-	-	210	156	102	-	-	-
	350	-	-	-	-	-	-	-	256	202	130	-	-
	400	-	-	-	-	-	-	-	-	302	230	158	-
	450	-	-	-	-	-	-	-	-	-	330	258	186
	500	-	-	-	-	-	-	-	-	-	-	358	286
	550	-	-	-	-	-	-	-	-	-	-	-	458
	600	-	-	-	-	-	-	-	-	-	-	-	-

Accuracy

Accuracy

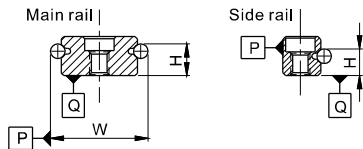

Unit : mm

Item	High(H)	Precision(P)
Tolerance of height H	±0.02	±0.01
Variation of height H	0.01	0.005
Tolerance of width W	±0.02	±0.01

Rail Length and Parallelism of The Raceway

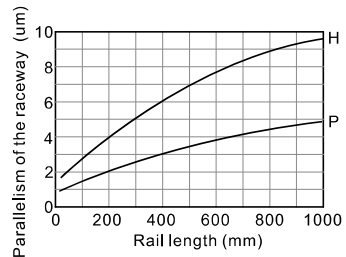

Specification Table

Dimensions of Three-row Type

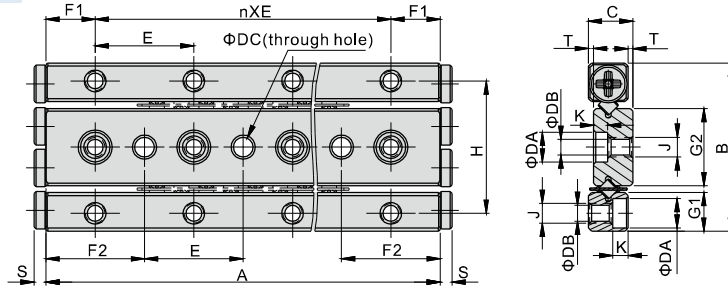

Model\Item	A	B	C	ΦDA	ΦDB	ΦDC	nXE	F1	F2	G1	G2	H	J	K	S	T
LGC1A20	20	17	4.5	3.0	1.55	2 ^{+0.03} / _{+0.005}	1X10	5	10	3.9	7.8	13.4	M2X0.4	1.5	1.2	0.5
LGC1A30	30						2X10									
LGC1A40	40						3X10									
LGC1A50	50						4X10									
LGC1A60	60						5X10									
LGC1A70	70						6X10									
LGC1A80	80						7X10									
LGC2A30	30						24									
LGC2A45	45	2X15														
LGC2A60	60	3X15														
LGC2A75	75	4X15														
LGC2A90	90	5X15														
LGC2A105	105	6X15														
LGC2A120	120	7X15														
LGC2A135	135	8X15														
LGC2A150	150	9X15														
LGC2A165	165	10X15														
LGC2A180	180	11X15														
LGC3A50	50	36	8.5	6.0	3.4	4 ^{+0.03} / _{+0.005}		1X25	12.5	25	8.3	16.6	29	M4X0.7	3.1	2
LGC3A75	75						2X25									
LGC3A100	100						3X25									
LGC3A125	125						4X25									
LGC3A150	150						5X25									
LGC3A175	175						6X25									
LGC3A200	200						7X25									
LGC3A225	225						8X25									
LGC3A250	250						9X25									
LGC3A275	275						10X25									
LGC3A300	300						11X25									
LGC4A80	80						44	11.5								
LGC4A120	120	2X40														
LGC4A160	160	3X40														
LGC4A200	200	4X40														
LGC4A240	240	5X40														
LGC4A280	280	6X40														
LGC4A320	320	7X40														
LGC4A360	360	8X40														
LGC4A400	400	9X40														
LGC4A440	440	10X40														
LGC4A480	480	11X40														

[Note] One set includes one main rail, two side rails, two roller cages, and the corresponding screws for mounting.

Specification Table

Dimensions of Four-row Type

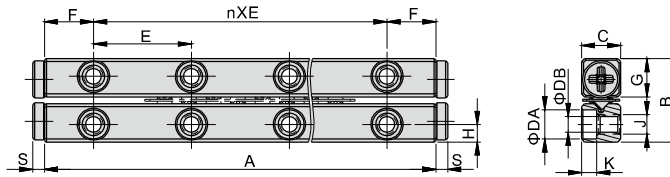

Model/Item	A	B	C	ΦDA	ΦDB	nXE	F	G	H	J	K	S
LGC1B20	20	8.5	4	3.0	1.55	1X10	5	3.9	1.8	M2X0.4	1.5	1.2
LGC1B30	30					2X10						
LGC1B40	40					3X10						
LGC1B50	50					4X10						
LGC1B60	60					5X10						
LGC1B70	70					6X10						
LGC1B80	80					7X10						
LGC2B30	30					12						
LGC2B45	45	2X15										
LGC2B60	60	3X15										
LGC2B75	75	4X15										
LGC2B90	90	5X15										
LGC2B105	105	6X15										
LGC2B120	120	7X15										
LGC2B135	135	8X15										
LGC2B150	150	9X15										
LGC2B165	165	10X15										
LGC2B180	180	11X15										
LGC3B50	50	18	8	6.0	3.4	1X25	12.5	8.3	3.5	M4X0.7	3.1	2
LGC3B75	75					2X25						
LGC3B100	100					3X25						
LGC3B125	125					4X25						
LGC3B150	150					5X25						
LGC3B175	175					6X25						
LGC3B200	200					7X25						
LGC3B225	225					8X25						
LGC3B250	250					9X25						
LGC3B275	275					10X25						
LGC3B300	300					11X25						
LGC4B80	80					22						
LGC4B120	120	2X40										
LGC4B160	160	3X40										
LGC4B200	200	4X40										
LGC4B240	240	5X40										
LGC4B280	280	6X40										
LGC4B320	320	7X40										
LGC4B360	360	8X40										
LGC4B400	400	9X40										
LGC4B440	440	10X40										
LGC4B480	480	11X40										
LGC6B100	100	31	15	9	5.3	1X50	25	14.7	6	M6X1.0	5.2	3
LGC6B150	150					2X50						
LGC6B200	200					3X50						
LGC6B250	250					4X50						
LGC6B300	300					5X50						
LGC6B350	350					6X50						
LGC6B400	400					7X50						
LGC6B450	450					8X50						
LGC6B500	500					9X50						
LGC6B550	550					10X50						
LGC6B600	600					11X50						

[Note] One set includes four side rails, two roller cages, and the corresponding screws for mounting.

LGC Series

Roller Cage Order Information

LGC 3 R25

① ② ③



① Model Code	LGC : Crossed Roller Way
② Roller Diameter	1 : Φ 1.5mm 2 : Φ 2.0mm
③ The number of rollers	3 : Φ 3.0mm 4 : Φ 4.0mm 6 : Φ 6.0mm
	R25:25 rollers [Reference to spec. table for detail]

Specification Table

Informations of Roller Cage

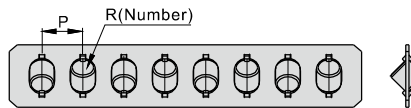

Model\Item	P	R	Basic Dynamic Load Rating (C _d)	Basic Static Load Rating (C _s)	Allowable Load (F _o)			
LGC1R6		6	125N per roller	120N per roller	39N per roller			
LGC1R7		7						
LGC1R8		8						
LGC1R9		9						
LGC1R10	2.5	10						
LGC1R11		11						
LGC1R13		13						
LGC1R16		16						
LGC1R19		19						
LGC2R6		6				292N per roller	290N per roller	97N per roller
LGC2R7		7						
LGC2R8		8						
LGC2R9		9						
LGC2R10		10						
LGC2R11		11						
LGC2R13		13						
LGC2R16	4	16						
LGC2R19		19						
LGC2R22		22						
LGC2R25		25						
LGC2R28		28						
LGC2R32		32						
LGC2R36		36						
LGC3R7		7	640N per roller	610N per roller	203N per roller			
LGC3R8		8						
LGC3R9		9						
LGC3R10		10						
LGC3R11		11						
LGC3R13		13						
LGC3R16		16						
LGC3R19	5	19						
LGC3R22		22						
LGC3R25		25						
LGC3R28		28						
LGC3R32		32						
LGC3R36		36						
LGC3R40		40						
LGC4R8		8	1230N per roller	1170N per roller	390N per roller			
LGC4R9		9						
LGC4R10		10						
LGC4R11		11						
LGC4R13		13						
LGC4R16		16						
LGC4R19		19						
LGC4R22	7	22						
LGC4R25		25						
LGC4R28		28						
LGC4R32		32						
LGC4R36		36						
LGC4R40		40						
LGC4R45		45						
LGC6R8		8				3175N per roller	2550N per roller	810N per roller
LGC6R9		9						
LGC6R11		11						
LGC6R13		13						
LGC6R16		16						
LGC6R19		19						
LGC6R22	9	22						
LGC6R25		25						
LGC6R28		28						
LGC6R32		32						
LGC6R36		36						
LGC6R40		40						
LGC6R45		45						

Installation Illustration

Three-row type--Installation method 1

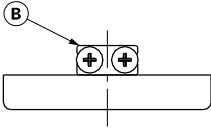
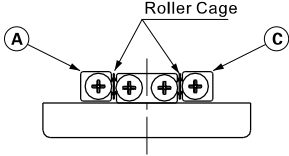
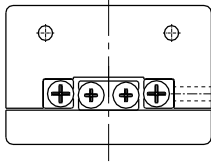
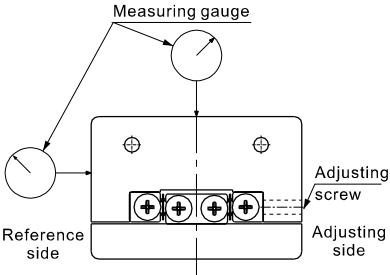
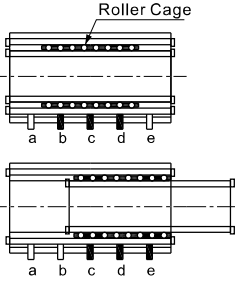
Step 1	Step 2	Step 3
<p>Lock the mounting screws on rail B with the recommended torque.</p> 	<p>Place the roller cage and rail A and C.</p> 	<p>Hold the rails to avoid moving, and temporarily fix the rail A and C after putting the slide table. Move the slide table back and forth to the end and adjust the roller cage to the center position of the rail.</p> 
Step 4	Step 5	Step 6
<p>Fix the measuring gauges to the top surface center and side surface (reference side) of the slide table.</p> 	<p>Move the slide table and tighten the adjusting screws within the roller range. Repeat the movement until the value of the measuring gauge drops to the lowest and keeps no change, then tighten the adjusting screws a~e with correct torque.</p> 	<p>Tighten the rail A and C completely, then perform the same steps as tightening the adjusting screws, move the slide table and tighten the mounting screws within the roller range with recommended torque.</p>

Three-row type--Installation method 2

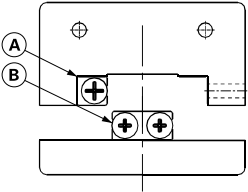
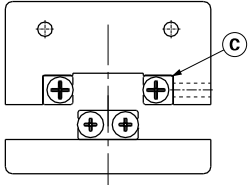
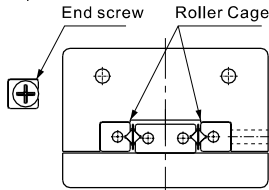
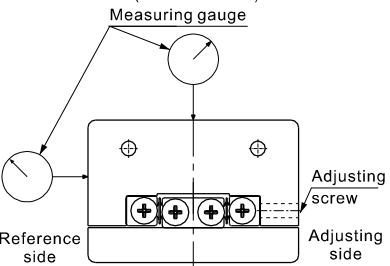
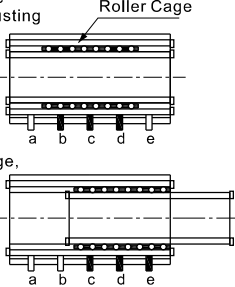
Step 1	Step 2	Step 3
<p>Lock the mounting screws on rail A and B with the recommended torque.</p> 	<p>Temporarily fix the rail C at the adjusting side.</p> 	<p>Removing the end screws on one side and insert the roller cage, then mount back the removed end screws and tighten. Move the slide table back and forth to the end and adjust the roller cage to the center position of the rail.</p> 
Step 4	Step 5	Step 6
<p>Fix the measuring gauges to the top surface center and side surface (reference side) of the slide table.</p> 	<p>Move the slide table and tighten the adjusting screws within the roller range. Repeat the movement until the value of the measuring gauge drops to the lowest and keeps no change, then tighten the adjusting screws a~e with correct torque.</p> 	<p>Tighten the rail C completely, then perform the same steps as tightening the adjusting screws, move the slide table and tighten the mounting screws within the roller range with recommended torque.</p>

LGC Series

Four-row type--Installation method 1

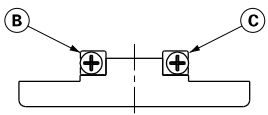
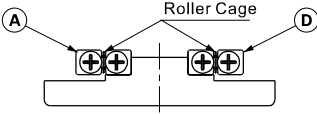
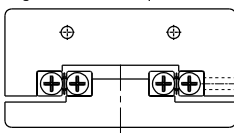
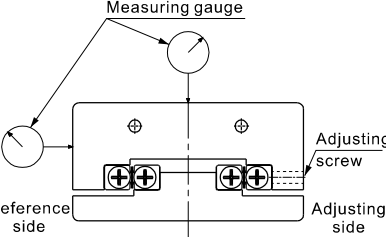
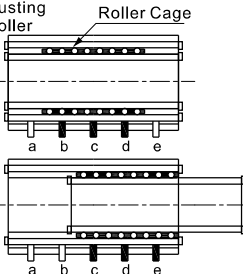
Step 1	Step 2	Step 3
<p>Lock the mounting screws on rail B and C with the recommended torque.</p> 	<p>Place the roller cage and rail A and D.</p> 	<p>Hold the rails to avoid moving, and temporarily fix the rail A and D after putting the slide table. Move the slide table back and forth to the end and adjust the roller cage to the center position of the rail.</p> 
Step 4	Step 5	Step 6
<p>Fix the measuring gauges to the top surface center and side surface (reference side) of the slide table.</p> 	<p>Move the slide table and tighten the adjusting screws within the roller range. Repeat the movement until the value of the measuring gauge drops to the lowest and keeps no change, then tighten the adjusting screws a~e with correct torque.</p> 	<p>Tighten the rail A and D completely, then perform the same steps as tightening the adjusting screws, move the slide table and tighten the mounting screws within the roller range with recommended torque.</p>

Four-row type--Installation method 2

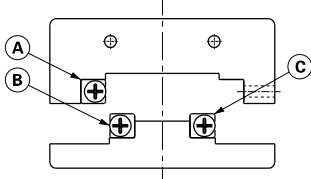
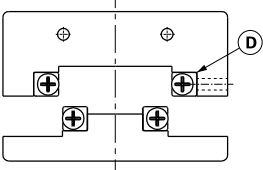
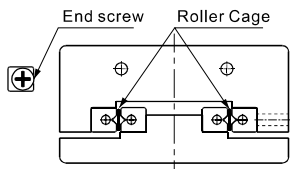
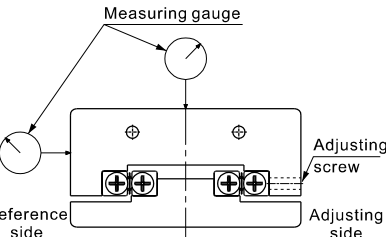
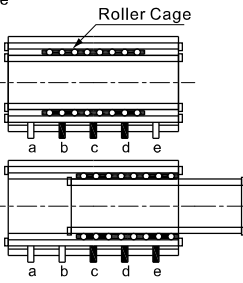
Step 1	Step 2	Step 3
<p>Lock the mounting screws on rail A, B and C with the recommended torque.</p> 	<p>Temporarily fix the rail D at the adjusting side.</p> 	<p>Removing the end screws on one side and insert the roller cage, then mount back the removed end screws and tighten. Move the slide table back and forth to the end and adjust the roller cage to the center position of the rail.</p> 
Step 4	Step 5	Step 6
<p>Fix the measuring gauges to the top surface center and side surface (reference side) of the slide table.</p> 	<p>Move the slide table and tighten the adjusting screws within the roller range. Repeat the movement until the value of the measuring gauge drops to the lowest and keeps no change, then tighten the adjusting screws a~e with correct torque.</p> 	<p>Tighten the rail D completely, then perform the same steps as tightening the adjusting screws, move the slide table and tighten the mounting screws within the roller range with recommended torque.</p>

Clearance adjustment

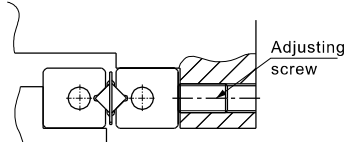
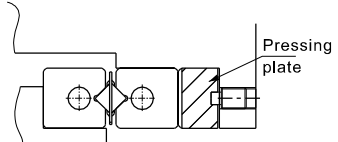
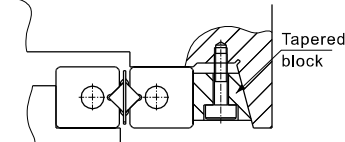
Application	Usually, the adjusting screw is used to push the rail on the adjusting side to adjust the clearance.	When rigidity and precision are required, pressing plate is recommended to adjust the clearance.	When high rigidity and high precision are particularly required, tapered block is recommended to adjust the clearance.
Diagram			

User Manual

Load Rating

Load direction	Vertical load		Lateral load	
Type	Three-Row type	Four-Row type	Three-Row type	Four-Row type
Schematic				
Basic dynamic load rating - C_a (N)	$C_a = \{2P \times (\frac{R}{2} - 1)\}^{\frac{1}{36}} \times (\frac{R}{2})^{\frac{3}{4}} \times C_r$ * Effective roller number R/2: round off to integer (EX : 5/2=2.5 , take 2)		$C_a = \{2P \times (\frac{R}{2} - 1)\}^{\frac{1}{36}} \times (\frac{R}{2})^{\frac{3}{4}} \times 2^{\frac{7}{9}} \times C_r$ *Effective roller number R/2: round off to integer (EX : 5/2=2.5 , take 2)	
Basic Static load rating - C_{a0} (N)	$C_{a0} = R \times C_r$		$C_{a0} = R \times C_r$	
Allowable load- F_{a0} (N)	$F_{a0} = R \times F_r$		$F_{a0} = R \times F_r$	

P: Pitch of roller cage (mm)
 R: The number of cylindrical rollers incorporated in a roller cage
 C_r : Basic dynamic load rating per cylindrical roller (N)
 C_{r0} : Basic static load rating per cylindrical roller (N)
 F_r : Allowable load per cylindrical roller (N)

Ex : Calculate LGC3A180R25 basic load rating
 From specification table(Informations of Roller Cage)
 Pitch of roller cage :P=5mm
 The number of cylindrical rollers incorporated in a roller cage : R = 25
 Basic dynamic load rating per cylindrical roller : $C_r = 640$ N
 Basic static load rating per cylindrical roller : $C_{r0} = 610$ N
 Allowable load per cylindrical roller: $F_r = 203$ N
 Effective roller number R/2 = 12.5, take 12
 Take these parameters into calculation, we can get
 For vertical load :Basic dynamic load rating $C_a = 4,701.88$ N;
 Basic Static load rating $C_{a0} = 15,250$ N;
 Allowable load $F_{a0} = 5,075$ N;
 For Lateral load : Basic dynamic load rating $C_a = 8,061.31$ N;
 Basic Static load rating $C_{a0} = 15,250$ N;
 Allowable load $F_{a0} = 5,075$ N.

Static Safety Factor(f_s)

Inertia force caused by impact, sudden start or stop will exert unexpected force on crossed roller guide. Therefore, safety factor based on working condition needs to be put into consideration, see as follows:

Load Condition	f_s
Normal Load	1.0~1.3
Load with Impacts or Vibrations	2.0~3.0

$$f_s = \frac{C_{a0}}{F}$$

f_s : Static safety factor
 C_{a0} : Basic static load rating (N)
 F: Calculated working load (N)

Nominal Life(L)

Nominal life is calculated as follow:

$$L = \left(\frac{f_r}{f_w} \cdot \frac{C_a}{F}\right)^{\frac{10}{3}} \times 100$$

L:Nominal life (km)
 C_a :Basic dynamic load rating (N)
 F:Calculated working load (N)
 f_r :Temperature factor (Reference to Temperature Factor Chart)
 f_w :Load factor (Reference to Load Factor Table)

Calculating the Service Life Time(L_s)

Based on the calculated nominal life, the Service Life Time is obtained through the following equation as if the stroke length and the value of reciprocations per minutes remain constant.

$$L_s = \frac{L \times 10^6}{2 \times l_r \times m \times 60}$$

L_s :Service life time (h)
 l_r :Stroke length (mm)
 m:Rounds per minute (min^{-1})

Temperature Factor(f_r)

If the environmental temperature exceeds 100°C, take the adverse effect of the high temperature into account by multiplying the basic load ratings by the temperature factor.

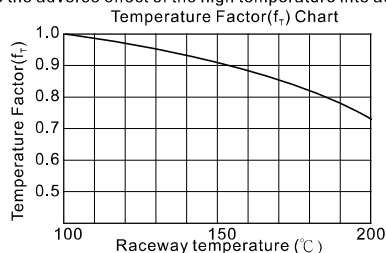

LGC Series

Load Factor(f_w)

In general, reciprocating machines tend to involve vibrations or impact during operation. It is extremely difficult to accurately determine the impact caused by high-speed motion or frequent start and stop motion. However, the calibrated load can be expected by experience. The basic load rating (C_r or C_{r0}) divide by load factor (f_w) in the following table to calibrate from speed effect and vibrations.

Load Factor Table		
Vibrations/Impact	Speed(V)	f_w
Faint	$V \leq 0.25\text{m/s}$	1~1.2
Weak	$0.25 < V \leq 1\text{m/s}$	1.2~1.5

Stroke

When moving, roller cage will move along with rail about half of its moving distance. Therefore, distance between center of loads and roller cage will vary with motion. In order to maintain accuracy, please conform to 'Cross Reference Table for Max. Stroke & Roller Numbers' table when deciding specs. EX: Choose spec for a roller diameter 6 mm, high accuracy type and desiring length of rails are 300 and 200 mm, desiring moving distance is 50 mm. Refer to 'Cross Reference Table for Max. Stroke & Roller Numbers': roller diameter 6 mm with 200 mm as shortest rail, its roller numbers can be R16 or R19, and admissible moving distance is 118 and 64 mm respectively. Both roller numbers can meet the required working distance 50mm.

Mounting Screw

Tightening torque for fixing screw

Spec	Screw size	Tightening torque(N.m)
LGC1	M1.4X0.3PX6L	0.14
LGC2	M2.0X0.4PX8L	0.40
LGC3	M3.0X0.5PX9.5L	1.40
LGC4	M4.0X0.7PX16L	3.20
LGC6	M5.0X0.8PX20L	6.60

Adjusting Screw

Tightening torque for fixing screw

Spec	Screw size	Tightening torque(N.m)
LGC1	M2	0.008
LGC2	M3	0.012
LGC3	M4	0.05
LGC4	M4	0.08
LGC6	M5	0.2

Gap between adjusting screws

It must have more than 2 of adjusting screws even the rails are short. When the rails are long, the gap between adjusting screws are recommended in the table below:

Spec	Gap between adjusting screws(mm)
LGC1	10
LGC2	15
LGC3	25
LGC4	40

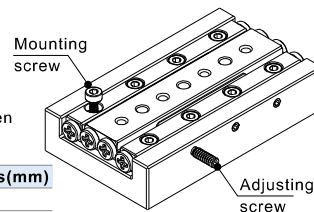

※High strength screw is preferred.

Allowable preload

Excessive preload will cause dents or shorten the lifetime, refer to the table below for allowable preload clearance. And check the amount of displacement of roller contact part while tightening the adjustment screw.

Spec	LGC1	LGC2	LGC3	LGC4
Allowable preload (um)	-2	-3	-4	-5

Precautions on dispensing

To avoid the screws from falling off by vibration, the screws thread can be dispensed before tightening. However, glue should not spill onto the roller and its contact surface to avoid affecting the walking accuracy.

Precautions on lubrication

- Linear guides have been treated with anti-rust oil in the factory. Before use, wipe the rail and treat with lubrication.
- When adding grease, in order to avoid the sliding resistance caused by uneven oil film, run back and forth several times before operation.
- Do not mix lubricating oil (grease) with different properties. Even if the thickeners of different grease are the same, they may affect each other due to different additives.
- In special environments such as places with frequent vibration, clean rooms, vacuum, low temperature or high temperature, use grease that meets the specifications and environment.
- Pay attention to that the consistency of the grease changes depending on the temperature, so the sliding resistance also changes.
- After adding grease, excess grease may splash around during operation, so wipe excess grease before using it when necessary.
- In order to avoid insufficient lubrication caused by grease loss, grease inspection and replenishment are required according to the frequency of use. The lubrication frequency varies depending on the use conditions and the environment, hence the lubrication frequency and replenishment should be set according to the actual operation.

Precautions on safety

- In high-speed use or bearing bias load, vibration, etc., roller cage offset may occur (Note 1), to avoid excessive extrusion, the stroke must be reserved when using, it is recommended that the operating stroke is slightly less than the maximum stroke to avoid cage extrusion damage.
- In order to obtain a high walking accuracy, it is recommended that the rail mounting surface should be ground to reach the same level or higher level to the parallelism and flatness of the rail, and the rails should be installed correctly close to the mounting surface.
- Be sure to remove the burrs, dents, dust, foreign objects, etc. of the rail mounting surface on the slide table and base, and pay attention to protection during assembly. When adjusting the preload, it is generally recommended to apply no or very small preload. Excessive preload can cause indentation damages and shorten the service life.

Precautions on use

1. Caution in handling

Dropping crossed roller way may cause damage on surface and further affect its accuracy, and even jerks during movement.

2. Adjustment

Fail to adjust the preload or mounting surfaces correctly will affect the product lifetime and accuracy. Make sure to assemble, install, and adjust the product with care. Appropriate preload will help with rigidity and accuracy; yet overloading the crossed roller way will result in damages and deformation. On installation, please follow the installation procedure and recommended torque.

3. Use as a Set

The accuracy of crossed roller guide is controlled as a set. Accuracy is not guaranteed when mixing parts from different sets.

4. Allowable Load

Definition of allowable load is the maximum loads applied on crossed roller to cause acceptable elastic deformation while maintain a smooth movement. When working condition requires high accuracy and smooth movement, be sure load applied on product is under allowable load.

5. Cage Slippage

The roller cage could slip under high speed motion, vertical use application, unbalanced load, and vibration conditions. Avoiding excessive loads is recommended. Meanwhile, using crossed roller within range of allowable stroke while applying safety factors will help avoid compression and damage.

6. Possible causes of cage offset

A. Vertical installation B. High speed or high acceleration application. C. Thermal deformation.

D. Structure rigidity or accuracy of the base or slide table are insufficient. E. Incorrect installation (the rails are not correctly aligned or have uneven preload)

7. Method of avoiding cage offset

During use, perform full-stroke movement multiple times to move the cage to the center position.

In vertical installation, the cage is affected by gravity and offset probability increases, hence the stroke must be reserved, if the situation is not improved, LRM/LSH series are recommended to use, in this case cage offset will not happen.

Headquarter, Sales Companies and Production Bases



Name: AirTAC International Group Taiwan Branch (CayMan)
 Office: 4F., No.129, Sec.3, Minsheng E. Rd., Songshan Dist.,
 Taipei City 10596, Taiwan
 Tel: +886-2-2719-7538
 Fax: +886-2-2719-7539
 Zip code: 10596
 Factory: No.28, Kanxi Rd., Xinshi Dist., Tainan City 74148, Taiwan
 Tel: +886-6-5896-889
 Fax: +886-6-5898-589
 Zip code: 74148



Name: Ningbo AirTAC Automatic Industrial Co., Ltd.
 Add: No.88, Siming E. Rd., High Tech Area of Fenghua District, Ningbo, Zhejiang, China
 Tel: +86-574-8895-0001
 Fax: +86-574-8895-0066
 Zip code: 315500



Name: Guangdong AirTAC Automatic Industrial Co., Ltd.
 Add: No. 7, Kaixuan Rd., Songxia Industrial Park, Shishan Town,
 Nanhai District, Foshan, Guangdong, China
 Tel: +86-757-8521-7188
 Fax: +86-757-8521-7841
 Zip code: 528234



Name: ATC (Italia) S.R.L.
 Add: Via Manzoni 20, 20020 Magnago (MI), Italy
 Tel: +39-0331-307204
 Fax: +39-0331-307208
 Zip code: 20020
 Email address: atc.it@airtac.com



Name: AIRTAC INDUSTRIAL(M) SDN BHD
 Johor: 22-01, Jalan Ekoperniagaan 1/3, Taman Ekoperniaagan,
 81100 Johor Bahru, Johor, Malaysia.
 Tel no.: +607-556 8989 Fax no.: +607-511 6699
 Selangor: Lot 5019, Jalan Pendamar 27/90, Section 27, 40400 Shah Alam,
 Selangor, Malaysia.
 Tel no: +603-5614 0592 Fax no: +603-5614 0912
 Penang: B1-03-12B, Elevate 1, Lorong Pauh Jaya 1/3, Taman Pauh Jaya,
 13500 Permatang Jaya, Pulau Pinang, Malaysia.
 Tel no: +604-386 6845 Fax no: +604-384 2671
 Email address: sales_my@airtac.com



Name: AirTAC Industrial Co., Ltd.
 Add: 11/12 M00 9, Bangchalong, Bangplee, Samutprakarn, 10540 Thailand.
 Tel: +66-2-023-3515
 Fax: +66-2-023-3518
 Zip code: 10540
 Email address: sales_thailand@airtac.com



Name: Airtac Co., Ltd.
 Add: 3-6-3, Kusune, Higashiosaka-shi, Osaka, Japan
 Tel: +81-6-4307-6039
 Fax: +81-6-4307-6038
 Zip code: 577-0006
 Email address: sales_jp@airtac.com



Name: AirTAC USA Corporation
 Add: 21201 Park Row Drive, Katy, Texas, 77449, USA
 Tel: +1-281-394-7177
 Fax: +1-281-394-7199
 Email address: sales_us@airtac.com

